

# 235 Washington Avenue

HPB25-0645

Historic Preservation Board

March 17, 2026



# Introduction

RYAN ALDERMAN  
ARCHITECT



# Basecamp305

- Innovative project-based learning: BaseCamp305 centers its curriculum on hands-on, project-based learning that encourages curiosity, exploration, innovation, communication, and real-world problem solving.
- Strong STEAM focus: Students engage with science, technology, engineering, arts, and math through activities like robotics, coding, design, and creative building.
- Small, personalized learning environment: BaseCamp305 emphasizes small class sizes and individualized attention, helping high-achieving students develop creativity, independence, and leadership skills.



Creativity



Technology



Community

# Approved School: 251 Washington Avenue Basecamp305



# Property Location

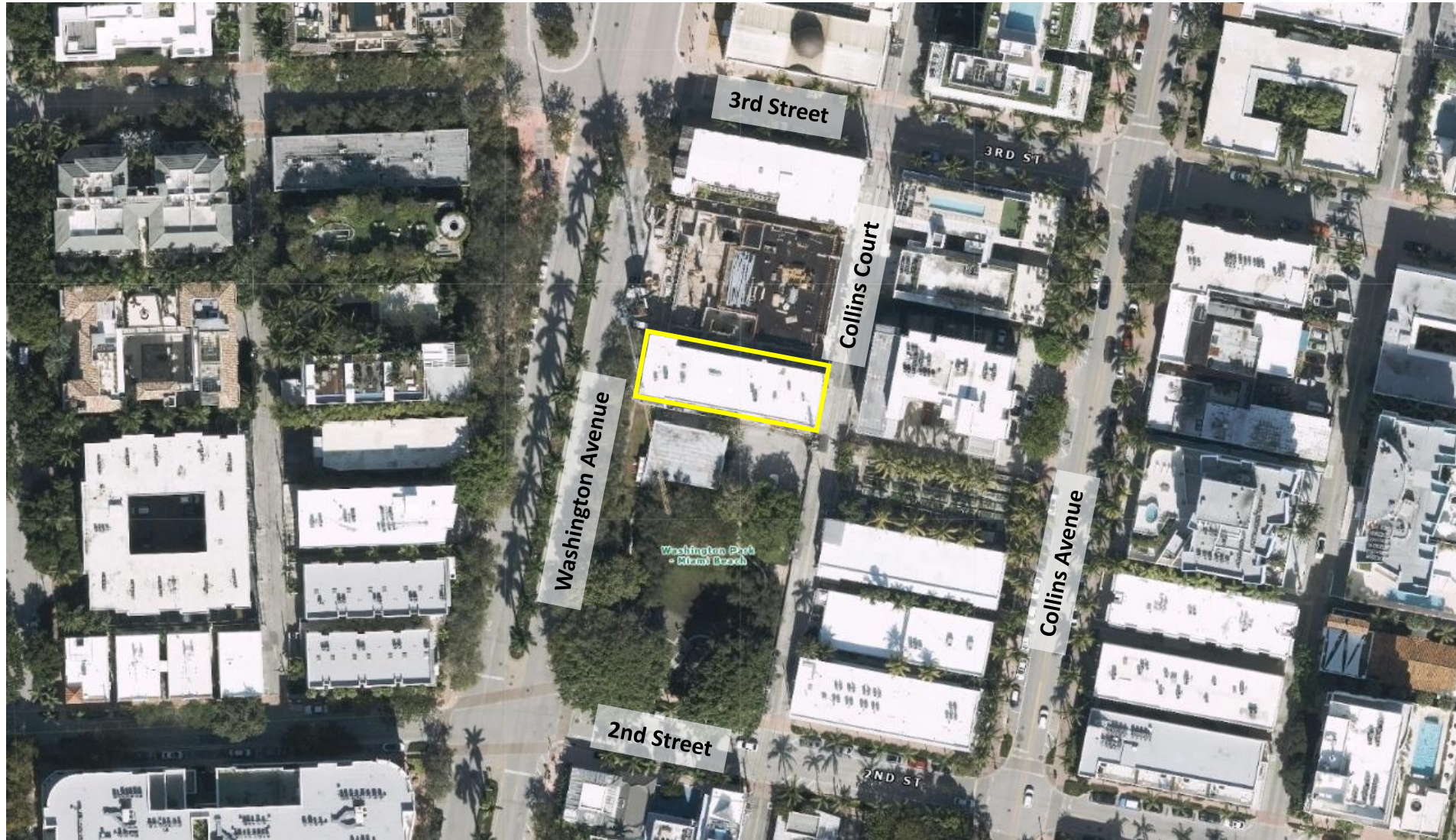

# Zoning and Historic District



**RPS-3**  
**Residential medium-  
high density**

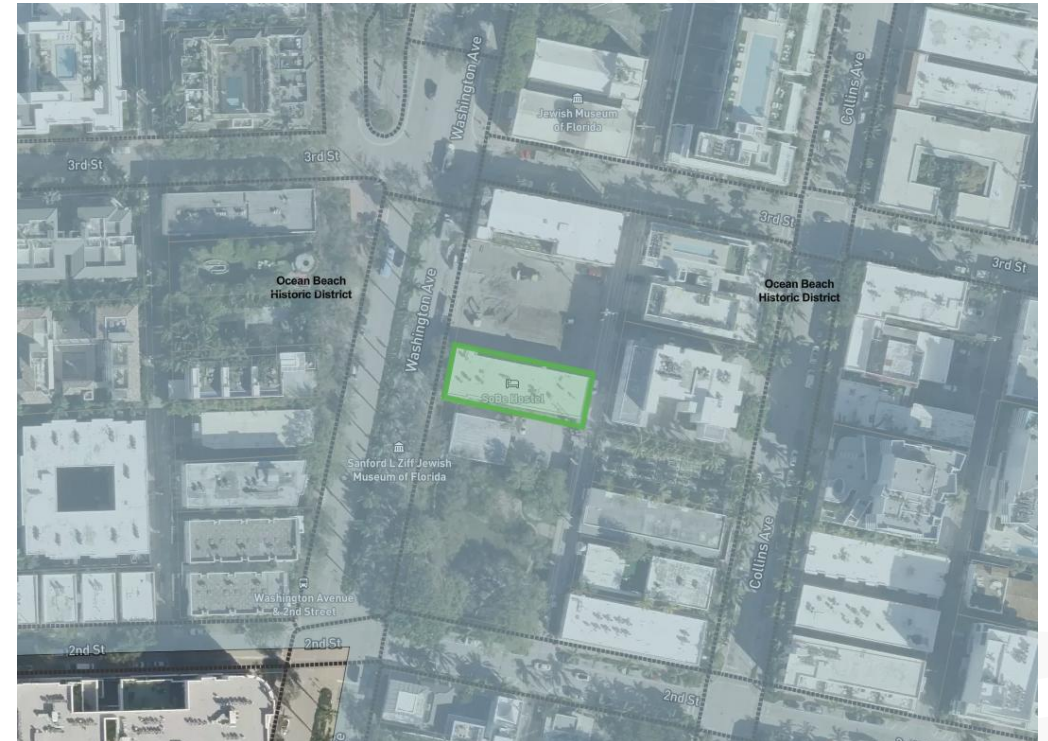

**Ocean Beach  
Historic District**  
*Contributing Building*

# Property Violations at Hostel

**Code Case Number** CE14006657

**Type** Noise Complaint

**Opened Date** 03/25/2014

**Address** 235 WASHINGTON AV Miami Beach

**Main Parcel** 0242030031070

**Status** Closed

**Project Name**

**Closed Date** 06/24/2024

**Code Case Number** BVC20000643

**Type** Building Violations – Combo

**Opened Date** 10/21/2020

**Address** 235 WASHINGTON AVE MIAMI BEACH FL -331397115

**Main Parcel** 0242030031070

**Status** Special Magistrate

**Project Name**

**Closed Date**

**Request Number** 2023-224270

**Type** Property Maintenance

**Date Entered** 04/13/2023

**Completion Date**

**Address** 235 WASHINGTON AVE MIAMI BEACH FL -331397115

**Main Parcel** 0242030031070

**Status** Notice of Violation Issued

**Project Name**

**Deadline Date** 04/13/2023

**Code Case Number** BVC21000784

**Type** Building Violations – Combo

**Opened Date** 08/25/2021

**Address** 235 WASHINGTON AVE MIAMI BEACH FL -331397115

**Main Parcel** 0242030031070

**Status** Special Magistrate

**Project Name**

**Closed Date**

**Request Number** 2022-154870

**Type** Sanitation Other

**Date Entered** 01/10/2022

**Completion Date**

**Address** 235 WASHINGTON AVE MIAMI BEACH FL -331397115

**Main Parcel** 0242030031070

**Status** Notice of Violation Issued

**Project Name**

**Deadline Date** 01/10/2022

**Code Case Number** BV16000831

**Type** Unsafe Structures

**Opened Date** 04/11/2016

**Address** 235 WASHINGTON AVE MIAMI BEACH FL -331397115

**Main Parcel** 0242030031070

**Status** Closed

**Project Name**

**Closed Date** 05/23/2016

- The City's CSS Portal reflects more than fifty (50) Code Case files associated with the Property prior to the Applicant's ownership



# Police Reports at Hostel

Incident Number	Call Date/Time	Dispositions	Location	Incident Type	Case Number
2024-00018172	2/15/2024 13:36	FI - 1	235 WASHINGTON AVE, Miami Beach	SUSPICIOUS PERSON	2024-00018172
2024-00005508	1/14/2024 14:48	RE - 1	235 WASHINGTON AVE, Miami Beach	SUSPICIOUS PERSON	
2023-00107994	12/11/2023 5:14	NR - 1	235 WASHINGTON AVE, Miami Beach	SUSPICIOUS PERSON	
2023-00103156	11/27/2023 13:35	NR - 1	235 WASHINGTON AVE, Miami Beach	TRAFFIC STOP	
2023-00083276	10/2/2023 19:13	NR - 1	235 WASHINGTON AVE, Miami Beach	SUSPICIOUS PERSON	
2023-00072776	8/29/2023 22:12	NR - 1	235 WASHINGTON AVE, Miami Beach	WATCHORDER	
2023-00071174	8/24/2023 17:48	TW - 1	235 WASHINGTON AVE, Miami Beach	SUSPICIOUS PERSON	2023-00071174
2023-00071160	8/24/2023 16:43	NR - 1	235 WASHINGTON AVE, Miami Beach	INCIDENT/MISC	
2023-00057076	7/7/2023 1:06	OI - 1	235 WASHINGTON AVE, Miami Beach	SUSPICIOUS PERSON	2023-00057076
2023-00021956	3/10/2023 3:53	RE - 9, OI - 1, AR - 2	235 WASHINGTON AVE, Miami Beach	SUSPICIOUS PERSON	2023-00021956
2023-00018694	3/1/2023 18:12	NR - 1	235 WASHINGTON AVE, Miami Beach	INCIDENT/MISC	
2022-00067803	8/13/2022 2:39	NR - 2	235 WASHINGTON AVE, Miami Beach	INCIDENT/MISC	
2022-00033171	4/18/2022 10:04	CA - 1	235 WASHINGTON AVE, Miami Beach	CRIME SCENE REQUEST	
2022-00033161	4/18/2022 9:17	NR - 1	235 WASHINGTON AVE, Miami Beach	BURGLARY	
2022-00032465	4/16/2022 0:03	OI - 1, FI - 1	235 WASHINGTON AVE, Miami Beach	BURGLARY	2022-00032465
2022-00017394	3/1/2022 16:22	OI - 1	235 WASHINGTON AVE, Miami Beach	BURGLARY	2022-00017394
2022-00003802	1/15/2022 12:24	NR - 1	235 WASHINGTON AVE, Miami Beach	ASSIST OTHER AGENCY	
2021-00088748	9/19/2021 22:07	NR - 1	235 WASHINGTON AVE, Miami Beach	SUSPICIOUS PERSON	
2021-00065777	7/1/2021 16:05	FL - 1	235 WASHINGTON AVE, Miami Beach	ACCIDENT	
2021-00028847	3/16/2021 14:52	RE - 20, OI - 2, AR - 2	235 WASHINGTON AVE, Miami Beach	STOLEN VEHICLE	2021-00028847
2020-00022942	3/15/2020 9:02	NR - 2	235 WASHINGTON AVE, Miami Beach	SUSPICIOUS PERSON	
2020-00022925	3/15/2020 6:59	NR - 1	235 WASHINGTON AVE, Miami Beach	DISTURBANCE	
2020-00018711	3/4/2020 3:52	EMS - 1, NR - 1	235 WASHINGTON AVE, Miami Beach	ASSIST OTHER AGENCY	
2020-00015943	2/23/2020 4:57	EMS - 1, NR - 1	235 WASHINGTON AVE, Miami Beach	SUSPICIOUS PERSON	
2020-00011247	2/6/2020 16:42	NR - 1	235 WASHINGTON AVE, Miami Beach	INCIDENT/MISC	
2020-00010609	2/4/2020 17:02	OI - 1	235 WASHINGTON AVE, Miami Beach	LARCENY	2020-00010609
2020-00010544	2/4/2020 11:57	NR - 1	235 WASHINGTON AVE, Miami Beach	FRAUD	
2020-00010432	2/4/2020 3:36	NR - 1	235 WASHINGTON AVE, Miami Beach	DISTURBANCE	
2020-00009505	2/1/2020 14:47	EMS - 1, NR - 1	235 WASHINGTON AVE, Miami Beach	SICK/INJ PERSON-PD	
2020-00002647	1/9/2020 7:18	OI - 1, AR - 1	235 WASHINGTON AVE, Miami Beach	DISTURBANCE	2020-00002647
2020-00002511	1/8/2020 20:09	NR - 1	235 WASHINGTON AVE, Miami Beach	DISTURBANCE	
2019-00112177	12/20/2019 7:07	NR - 2	235 WASHINGTON AVE, Miami Beach	DISTURBANCE	
2019-00103026	11/19/2019 10:51	OI - 1	235 WASHINGTON AVE, Miami Beach	LARCENY	2019-00103026



- MBPD records reflect 59 Police Reports associated with Property since 2019.

# Context

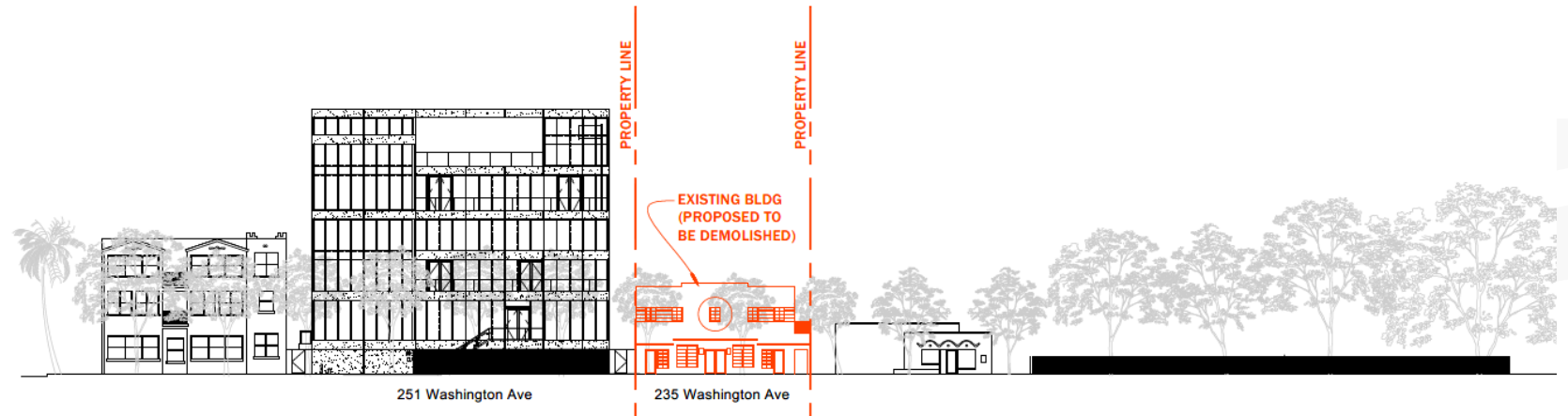
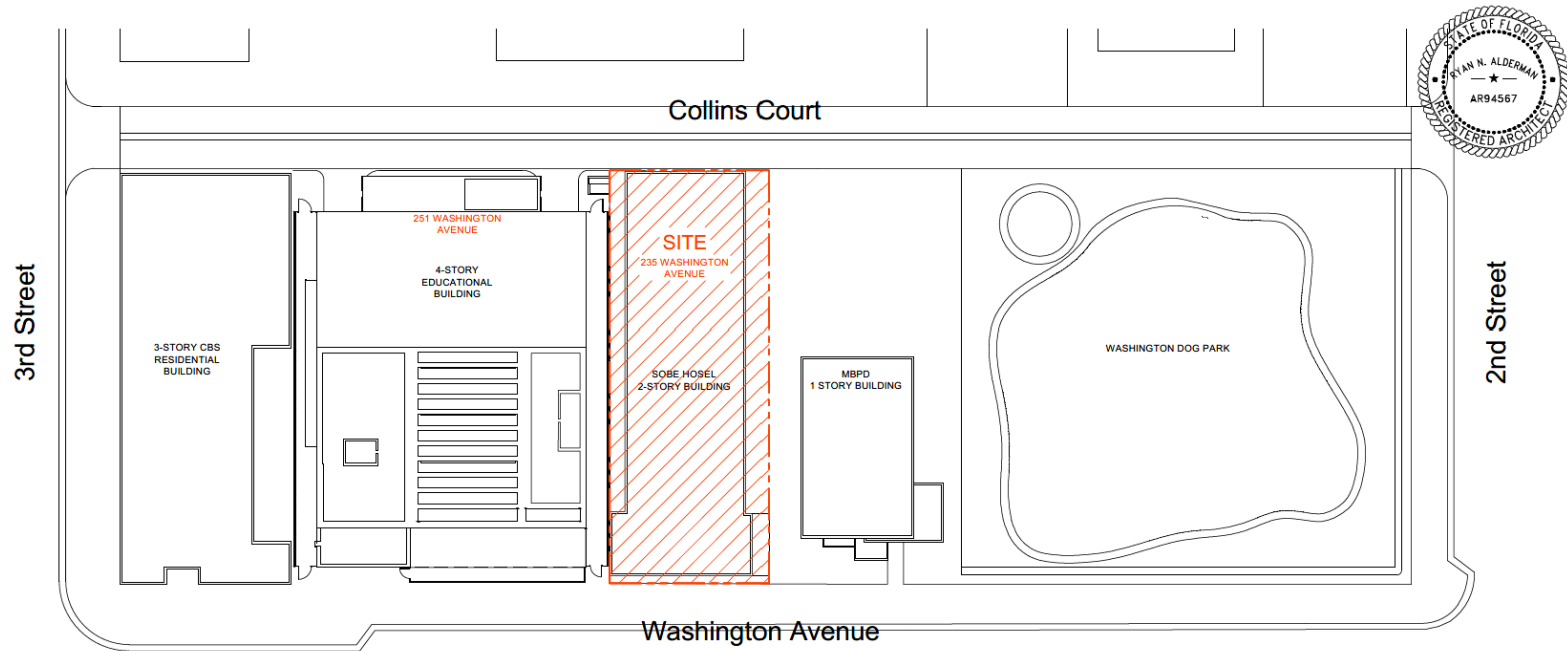

# Current Conditions



# Current Conditions



Spall and delaminated stucco and concrete present



Spall and delaminated stucco and concrete present



Termite dropping and stud damage

# Importance of Recreational Space

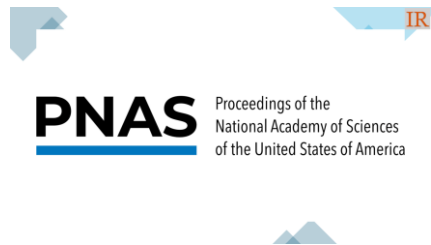

RESEARCH ARTICLE | ENVIRONMENTAL SCIENCES |



## Green spaces and cognitive development in primary schoolchildren

## The Role of Recess in Children's Cognitive Performance and School Adjustment

[Anthony D. Pellegrini](#) and [Catherine M. Bohn](#) [View all authors and affiliations](#)

- Studies have found that exposure to green space around schools was associated with improved working memory and reduced inattentiveness.
- Recess improves attention, on-task behavior, and classroom productivity.
- Access to outdoor recreational space has been associated with reduced stress levels, improved emotional regulation, and enhanced overall student well-being, which supports a more positive and effective learning environment.



# Proposed Recreational Plan

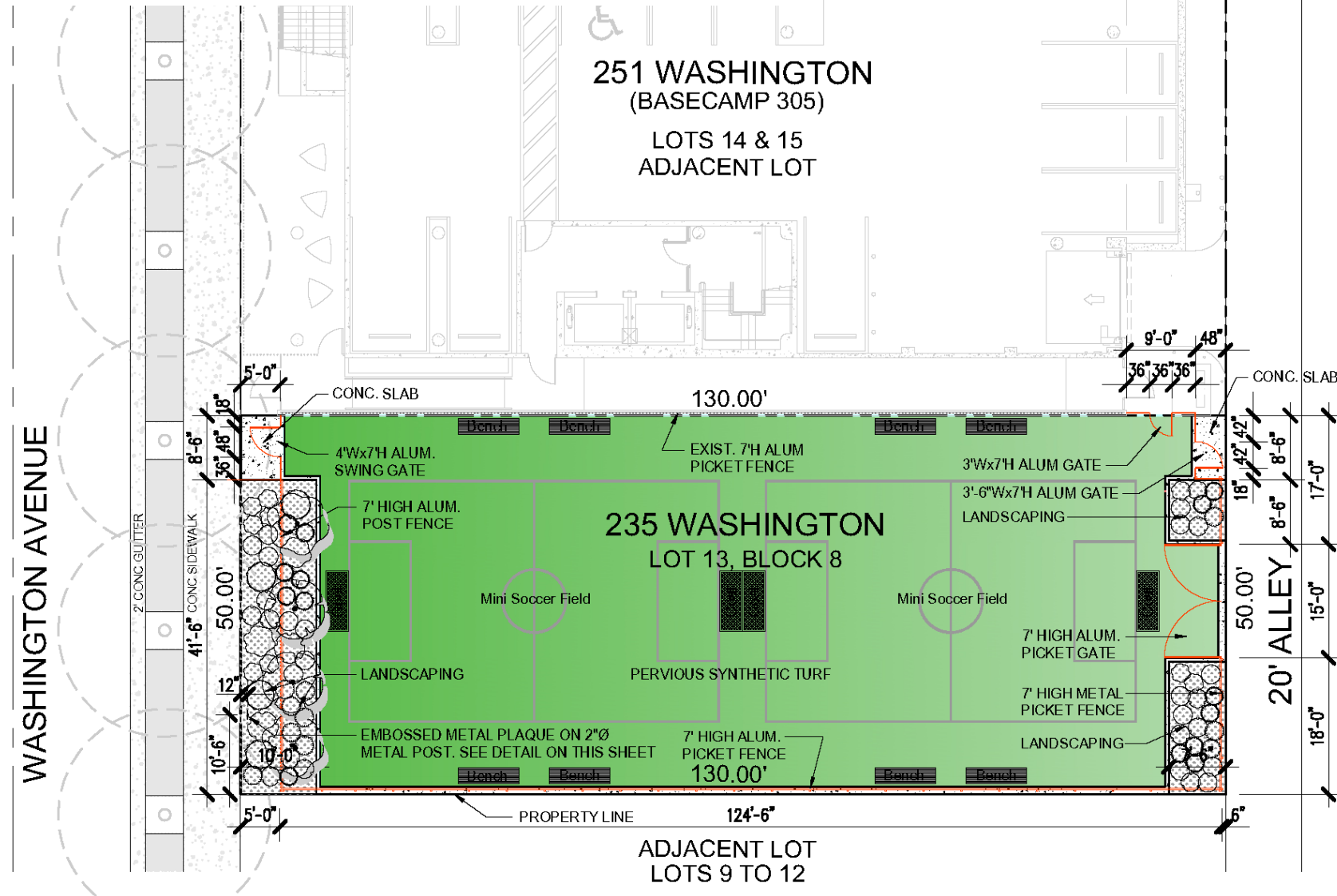

# Turf and Hardscape

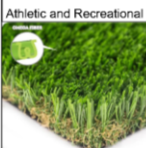
REFERENCE NOTES SCHEDULE							
PHOTO	CODE	DESCRIPTION	QTY	Specification	Source	Color	FINISH
	32-13-01	6" Fiber Reinforced Concrete Header Curb	63 lf	6"(W) x 12"(L)		Gray Concrete	Broom Finish
	32-13-02	12" Fiber Reinforced Concrete Header Curb	256 lf	12"(W) X 12"(L)		Gray Concrete	Broom Finish
	32-18-01	TURF	5,648 sf	1.75" Tall	Tiger Turf	Everglade Spring Pro	

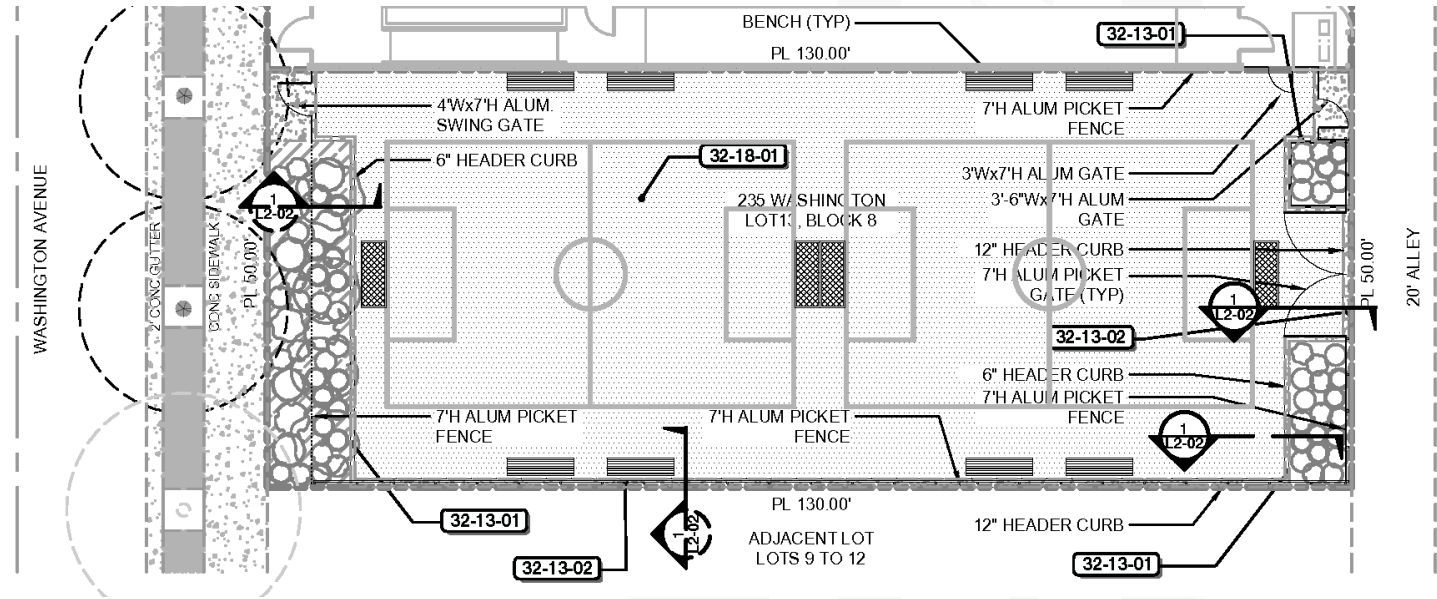
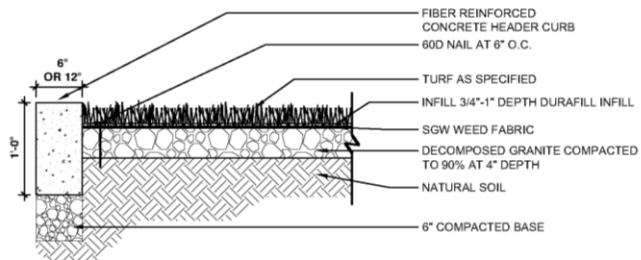

- **Product:** TigerTurf Everglade Spring Pro — a permeable synthetic turf with a drainage rate of 30+ inches per hour per square yard.
- **Performance & Application:** Engineered for high-traffic environments and continuous youth recreation, providing superior shock absorption and long-term durability.

# TigerTurf Everglade Spring Pro



- Multi-tone blend of field and lime green fibers with a brown thatch layer creates a natural grass appearance that integrates seamlessly into the campus environment
- Maintains a uniform and visually consistent open-space surface despite intensive daily student use, avoiding the deterioration and patchiness typical of natural sod in high-traffic school settings
- Permeable system supports on-site drainage and prevents standing water, ensuring the recreation area remains functional without creating runoff or maintenance concerns

# Fence Elevations

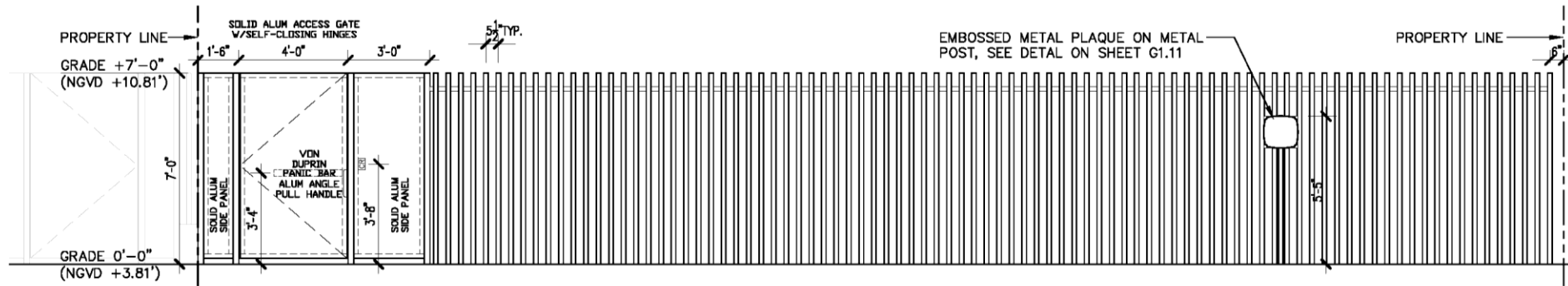

1 West Elevation (Washington) 1/4" = 1'-0"  
G1.12 7' High Aluminum Fence & Gate

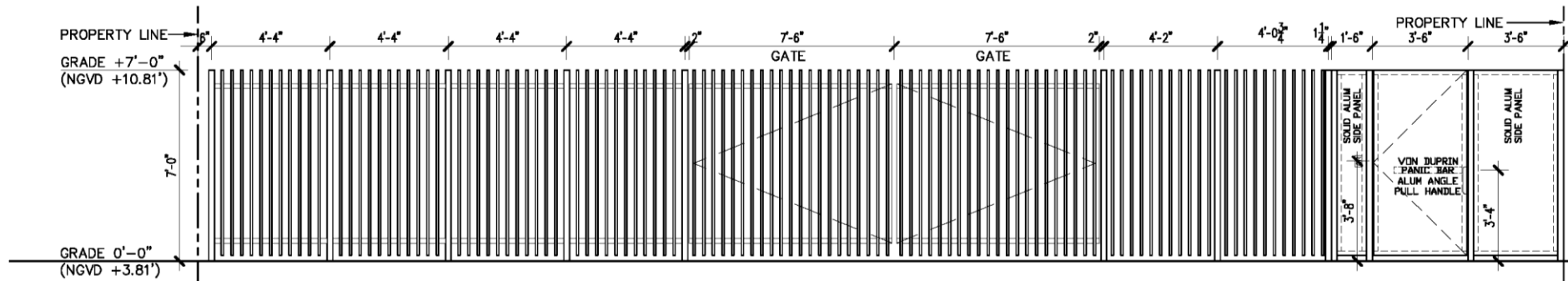

2 East Elevation (Alley) 1/4" = 1'-0"  
G1.12 7' High Aluminum Fence & Gates



3 South Elev (Adj. Property) 3/32" = 1'-0"  
G1.12 7' High Aluminum Fence

RYAN ALDERMAN  
ARCHITECT  
14970 E Falcons Lea Dr.  
Davie, Florida 33331  
P: 305.801.9185



# Proposed Elevation: Washington Avenue



# Proposed Elevation: Washington Avenue



# Flooding Issues

Figure 10 of the City's 2024 Stormwater Master Plan (LOS Compliance Map) indicates that the subject property is located in close proximity to areas identified as failing the adopted stormwater Level of Service standard, reflecting limited available capacity within the surrounding public drainage system during design storm events.



Figure 10, 2024 SWMP LOS Compliance Map

# Flooding Issues

254167	2021-07-19 12:57 PM	Standing Water (0-3 Inches)	3	STORM	THOMAS, CHAQUENTA	GARDNER, KEIYATTA G	234 WASHINGTON AVE
254298	2021-07-22 07:18 AM	Standing Water (0-3 Inches)	3	STORM	THOMAS, CHAQUENTA	GARDNER, KEIYATTA G	234 WASHINGTON AVE
262189	2022-07-15 07:24 AM	Catch basin backup	3	SEWER	BOODOO, RANDY	PEREZ, JR. ALFREDO	260 Euclid Ave Miami Beach 33139
263560	2022-09-19 09:24 AM	Standing Water (0-3 Inches)	3	STORM	THOMAS, CHAQUENTA	GARDNER, KEIYATTA G	234 Washington Ave, Miami Beach, FL 33139, USA
270485	2023-09-28 02:21 AM	Standing Water (0-3 Inches)	3	STORM	THOMAS, CHAQUENTA	GARDNER, KEIYATTA G	234 WASHINGTON AVE, 33139
270513	2023-09-30 06:17 AM	Significant Standing Water (3-6 Inches)	3	STORM	THOMAS, CHAQUENTA	GARDNER, KEIYATTA G	234 Washington Ave, Miami Beach, FL 33139, USA
270673	2023-10-10 08:51 AM	Standing Water (0-3 Inches)	3	STORM	THOMAS, CHAQUENTA	GARDNER, KEIYATTA G	234 WASHINGTON AVE, 33139
279912	2025-03-11 01:03 AM	Standing Water (0-3 Inches)	3	STORM	THOMAS, CHAQUENTA	GARDNER, KEIYATTA G	230 COLLINS CT, Miami Beach, Florida, 33139
282257	2025-07-18 07:12 AM	Standing Water (0-3 Inches)	3	STORM	THOMAS, CHAQUENTA	GARDNER, KEIYATTA G	234 Washington Ave, Miami Beach, FL 33139, USA
283570	2025-10-02 11:11 AM	Standing Water (0-3 Inches)	3	STORM	THOMAS, CHAQUENTA	GARDNER, KEIYATTA G	234 WASHINGTON AVE, Miami Beach, Florida, 33139
283770	2025-10-13 04:25 AM	Catch basin backup	3	STORM	THOMAS, CHAQUENTA	GARDNER, KEIYATTA G	220 WASHINGTON AVE, Miami Beach, Florida, 33139

- City records indicate that Public Works receives multiple calls annually reporting flood-related issues in the immediate area.

# Elevation Certificate

ELEVATION CERTIFICATE			OMB No. 1660-0008 Expiration Date: November 30, 2022																																
<b>IMPORTANT: In these spaces, copy the corresponding information from Section A.</b>			<b>FOR INSURANCE COMPANY USE</b>																																
Building Street Address (including Apt., Unit, Suite, and/or Bldg. No.) or P.O. Route and Box No. 235 WASHINGTON AVENUE			Policy Number:																																
City MIAMI BEACH	State Florida	ZIP Code 33139	Company NAIC Number																																
<b>SECTION C – BUILDING ELEVATION INFORMATION (SURVEY REQUIRED)</b>																																			
<p>C1. Building elevations are based on: <input type="checkbox"/> Construction Drawings* <input type="checkbox"/> Building Under Construction* <input checked="" type="checkbox"/> Finished Construction                      *A new Elevation Certificate will be required when construction of the building is complete.</p> <p>C2. Elevations – Zones A1–A30, AE, AH, A (with BFE), VE, V1–V30, V (with BFE), AR, AR/A, AR/AE, AR/A1–A30, AR/AH, AR/AO. Complete Items C2.a–h below according to the building diagram specified in Item A7. In Puerto Rico only, enter meters.                      Benchmark Utilized: MIAMI-DADE CO. B.M. AC0474 Vertical Datum: NGVD 1929</p> <p>Indicate elevation datum used for the elevations in items a) through h) below.  <input checked="" type="checkbox"/> NGVD 1929 <input type="checkbox"/> NAVD 1988 <input type="checkbox"/> Other/Source: _____</p> <p>Datum used for building elevations must be the same as that used for the BFE. Check the measurement used.</p> <table border="0"> <tr> <td>a) Top of bottom floor (including basement, crawlspace, or enclosure floor)</td> <td>6.1</td> <td><input checked="" type="checkbox"/> feet</td> <td><input type="checkbox"/> meters</td> </tr> <tr> <td>b) Top of the next higher floor</td> <td>8.1</td> <td><input checked="" type="checkbox"/> feet</td> <td><input type="checkbox"/> meters</td> </tr> <tr> <td>c) Bottom of the lowest horizontal structural member (V Zones only)</td> <td>N.A.</td> <td><input type="checkbox"/> feet</td> <td><input type="checkbox"/> meters</td> </tr> <tr> <td>d) Attached garage (top of slab)</td> <td>N.A.</td> <td><input checked="" type="checkbox"/> feet</td> <td><input type="checkbox"/> meters</td> </tr> <tr> <td>e) Lowest elevation of machinery or equipment servicing the building (Describe type of equipment and location in Comments)</td> <td>N.A.</td> <td><input checked="" type="checkbox"/> feet</td> <td><input type="checkbox"/> meters</td> </tr> <tr> <td>f) Lowest adjacent (finished) grade next to building (LAG)</td> <td>6.1</td> <td><input checked="" type="checkbox"/> feet</td> <td><input type="checkbox"/> meters</td> </tr> <tr> <td>g) Highest adjacent (finished) grade next to building (HAG)</td> <td>6.2</td> <td><input checked="" type="checkbox"/> feet</td> <td><input type="checkbox"/> meters</td> </tr> <tr> <td>h) Lowest adjacent grade at lowest elevation of deck or stairs, including structural support</td> <td>N.A.</td> <td><input checked="" type="checkbox"/> feet</td> <td><input type="checkbox"/> meters</td> </tr> </table>				a) Top of bottom floor (including basement, crawlspace, or enclosure floor)	6.1	<input checked="" type="checkbox"/> feet	<input type="checkbox"/> meters	b) Top of the next higher floor	8.1	<input checked="" type="checkbox"/> feet	<input type="checkbox"/> meters	c) Bottom of the lowest horizontal structural member (V Zones only)	N.A.	<input type="checkbox"/> feet	<input type="checkbox"/> meters	d) Attached garage (top of slab)	N.A.	<input checked="" type="checkbox"/> feet	<input type="checkbox"/> meters	e) Lowest elevation of machinery or equipment servicing the building (Describe type of equipment and location in Comments)	N.A.	<input checked="" type="checkbox"/> feet	<input type="checkbox"/> meters	f) Lowest adjacent (finished) grade next to building (LAG)	6.1	<input checked="" type="checkbox"/> feet	<input type="checkbox"/> meters	g) Highest adjacent (finished) grade next to building (HAG)	6.2	<input checked="" type="checkbox"/> feet	<input type="checkbox"/> meters	h) Lowest adjacent grade at lowest elevation of deck or stairs, including structural support	N.A.	<input checked="" type="checkbox"/> feet	<input type="checkbox"/> meters
a) Top of bottom floor (including basement, crawlspace, or enclosure floor)	6.1	<input checked="" type="checkbox"/> feet	<input type="checkbox"/> meters																																
b) Top of the next higher floor	8.1	<input checked="" type="checkbox"/> feet	<input type="checkbox"/> meters																																
c) Bottom of the lowest horizontal structural member (V Zones only)	N.A.	<input type="checkbox"/> feet	<input type="checkbox"/> meters																																
d) Attached garage (top of slab)	N.A.	<input checked="" type="checkbox"/> feet	<input type="checkbox"/> meters																																
e) Lowest elevation of machinery or equipment servicing the building (Describe type of equipment and location in Comments)	N.A.	<input checked="" type="checkbox"/> feet	<input type="checkbox"/> meters																																
f) Lowest adjacent (finished) grade next to building (LAG)	6.1	<input checked="" type="checkbox"/> feet	<input type="checkbox"/> meters																																
g) Highest adjacent (finished) grade next to building (HAG)	6.2	<input checked="" type="checkbox"/> feet	<input type="checkbox"/> meters																																
h) Lowest adjacent grade at lowest elevation of deck or stairs, including structural support	N.A.	<input checked="" type="checkbox"/> feet	<input type="checkbox"/> meters																																
<b>SECTION D – SURVEYOR, ENGINEER, OR ARCHITECT CERTIFICATION</b>																																			
<p>This certification is to be signed and sealed by a land surveyor, engineer, or architect authorized by law to certify elevation information. I certify that the information on this Certificate represents my best efforts to interpret the data available. I understand that any false statement may be punishable by fine or imprisonment under 18 U.S. Code, Section 1001.</p> <p>Were latitude and longitude in Section A provided by a licensed land surveyor? <input checked="" type="checkbox"/> Yes <input type="checkbox"/> No <input type="checkbox"/> Check here if attachments.</p> <table border="1"> <tr> <td>Certifier's Name CLYDE MCNEAL</td> <td>License Number LB 8111</td> <td colspan="2" rowspan="4"></td> </tr> <tr> <td>Title SURVEYOR</td> <td></td> </tr> <tr> <td>Company Name NEXGEN SURVEYING, LLC.</td> <td></td> </tr> <tr> <td>Address 1421 OLGLETHORPE ROAD</td> <td></td> </tr> <tr> <td>City WEST PALM BEACH</td> <td>State Florida</td> <td>ZIP Code 33405</td> <td></td> </tr> <tr> <td>Signature </td> <td>Date 03/02/2023</td> <td>Telephone (561) 508-6272</td> <td></td> </tr> </table> <p>Copy all pages of this Elevation Certificate and all attachments for (1) community official, (2) insurance agent/company, and (3) building owner.                      Comments (including type of equipment and location, per C2(e), if applicable)</p> <p>This information is being collected for the primary purpose of estimating the risk premium rates necessary to provide flood insurance and is not to be used for any construction permitting purposes.                      Latitude/Longitude in A5 derived from Google Maps.</p>				Certifier's Name CLYDE MCNEAL	License Number LB 8111			Title SURVEYOR		Company Name NEXGEN SURVEYING, LLC.		Address 1421 OLGLETHORPE ROAD		City WEST PALM BEACH	State Florida	ZIP Code 33405		Signature 	Date 03/02/2023	Telephone (561) 508-6272															
Certifier's Name CLYDE MCNEAL	License Number LB 8111																																		
Title SURVEYOR																																			
Company Name NEXGEN SURVEYING, LLC.																																			
Address 1421 OLGLETHORPE ROAD																																			
City WEST PALM BEACH	State Florida	ZIP Code 33405																																	
Signature 	Date 03/02/2023	Telephone (561) 508-6272																																	

- The existing first floor finished floor elevation is at **6.1' NGVD**.
- The structure is below the flood elevation, as the FEMA maps establish the elevation at **8.00' NGVD**.
- New construction is built at **10.00' NGVD** (8.00' BFE + 2.00' Freeboard).



# Existing Elevation Profile



# Staff Report Excerpt

The replication of demolished structures is generally discouraged, and reconstruction has been considered in the past under extenuating circumstances. Where replication is determined to be appropriate, reconstruction is expected to closely reflect the original dimensions, scale and massing of the demolished structure. In this particular instance replicating the subject building, in a usable manner, would be very challenging as the first floor could not be used for any type of habitable use. Raising a replicated structure to meet current base flood elevation and freeboard requirements would result in a highly awkward building that does not properly reflect the scale, massing and design of the original structure.

HPB25-0645 – 235 Washington Avenue  
March 17, 2026

Page 8 of 8

Although the existing structure is classified as 'contributing' it contains only modest design details, and the replication of the structure is not recommended. Given the advanced state of structural decline, substantiated in the engineering report, staff is supportive of the request for total demolition.

# Structural Assessment by Youssef Hachem, P.E.

- Site observations
- Current structural systems
- Structural evaluations
- Concrete testing

# Site Observations from Structural Report

1. Roof structure failures leading to water intrusion and wood members sagging, rotting, failing, and total collapse in multiple areas
2. Concrete columns and beams exhibit spalling affecting approximately 40% of their surface area, with cracking evident throughout the building
3. Evidence of prior repair areas re-cracking
4. Presence of mold and water intrusion on interior walls and ceilings exhibit varying levels of failure



Termite dropping and stud damage



Spall and delaminated stucco and concrete present

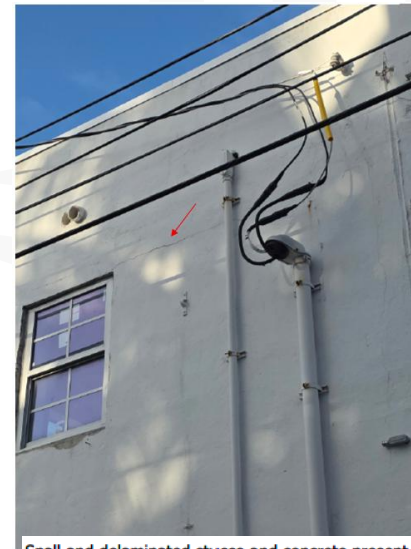

Spall and delaminated stucco and concrete present

# Structural Systems

- Distress signs: cracking, spalling, water damage, and termite damage
- Structural system: the building's structural system, including concrete columns, beams, slabs, and load-bearing walls, does not comply with the current Florida Building Code

# Foundation

- Slab on grade
- Shallow foundation supporting concrete stem walls
- Foundation has to be strengthened to resist lateral loads

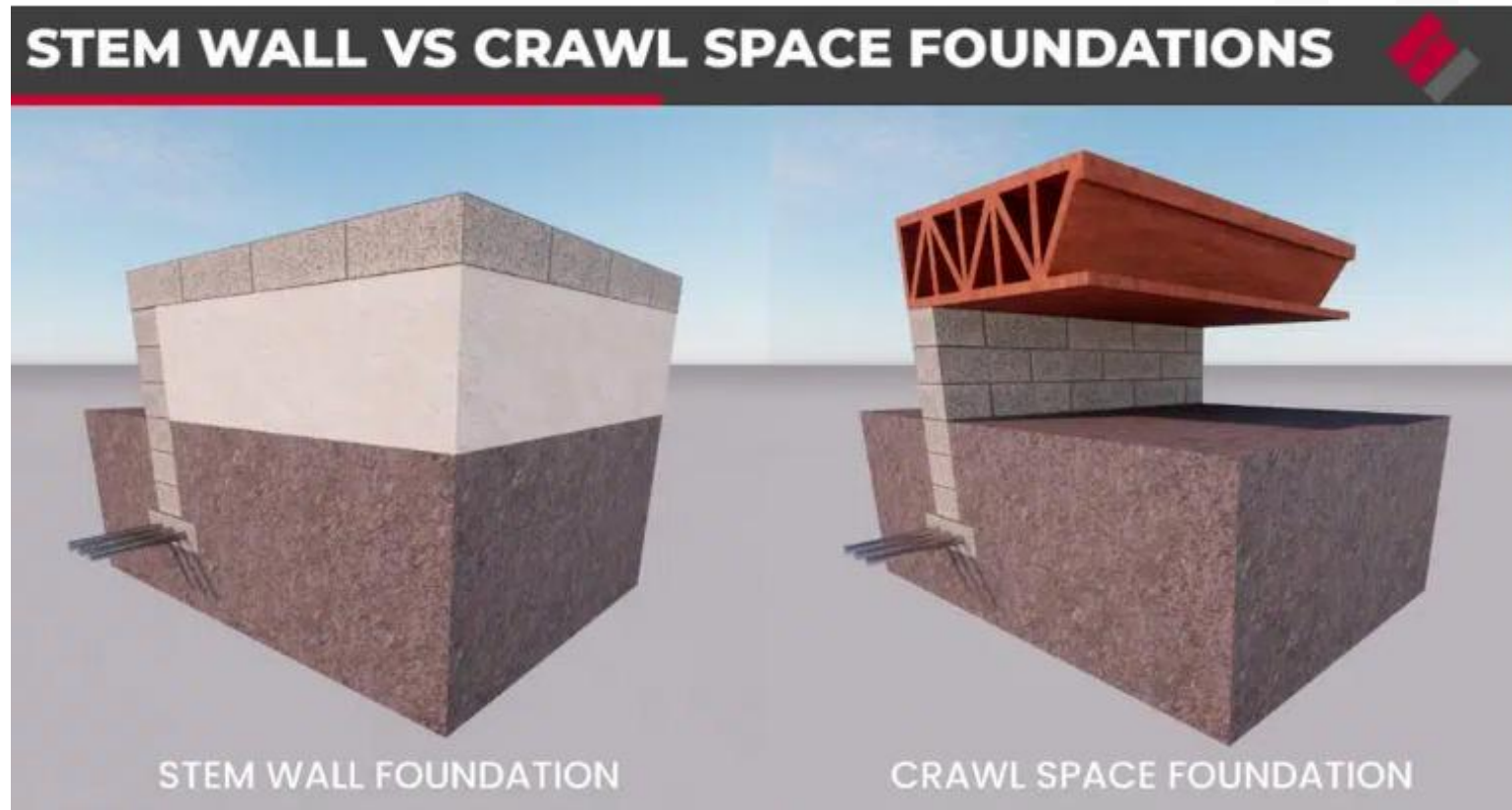

# Floors

- All wood joists are “fire cut” into the wood wall, not connected to walls via strapping or any other mechanism

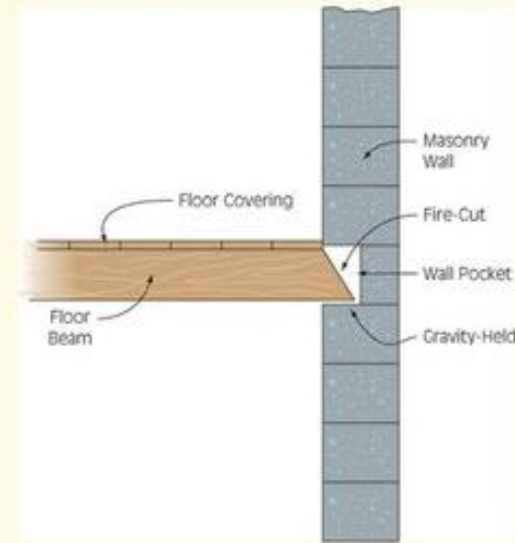
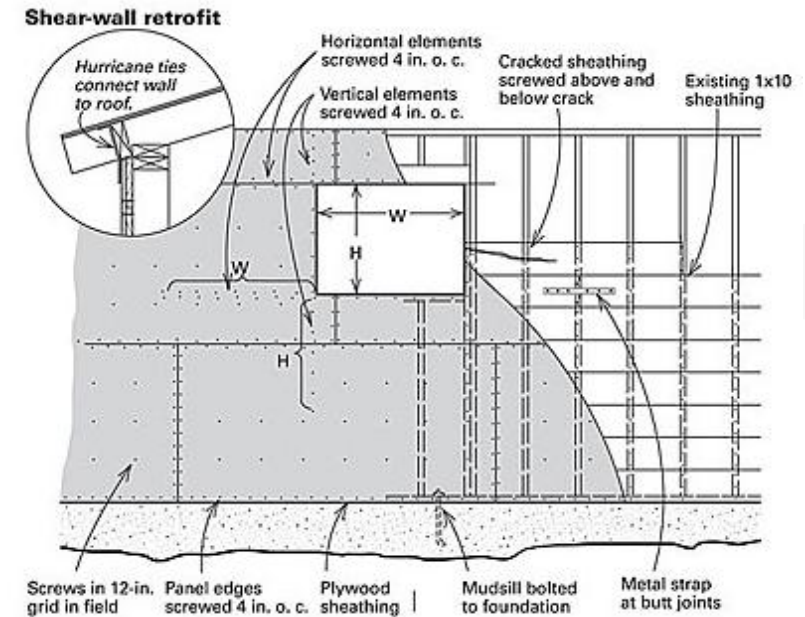

Figure 13-20 Wood and heavy timber beams were often “fire-cut” so that a fire-damaged, sagging floor would simply slide out of the wall pocket in order to preserve the wall.



# Walls and Openings

- Opening protection and wood reinforcing is non-existent
- Requires shearwalls to be installed in order for the building to be Florida Building Code compliant



# Roof

- Roof waterproofing has failed in multiple locations
- Connections for wind uplift forces and wind lateral resistance are non-existent
- Requires roof connection tie-downs be installed to strengthen the roof for Florida Building Code compliance

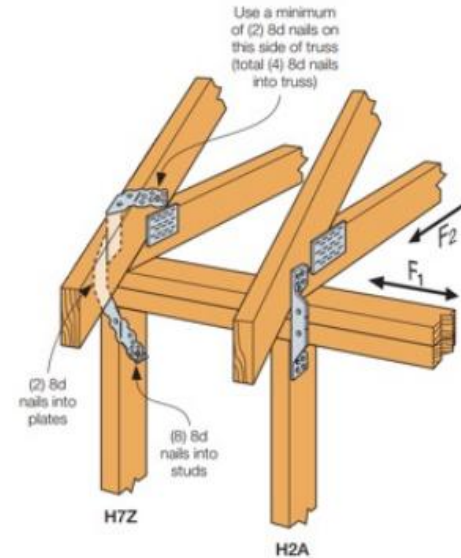
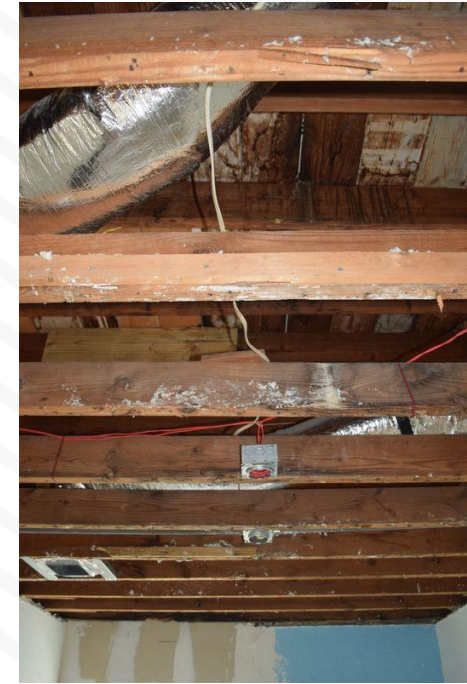
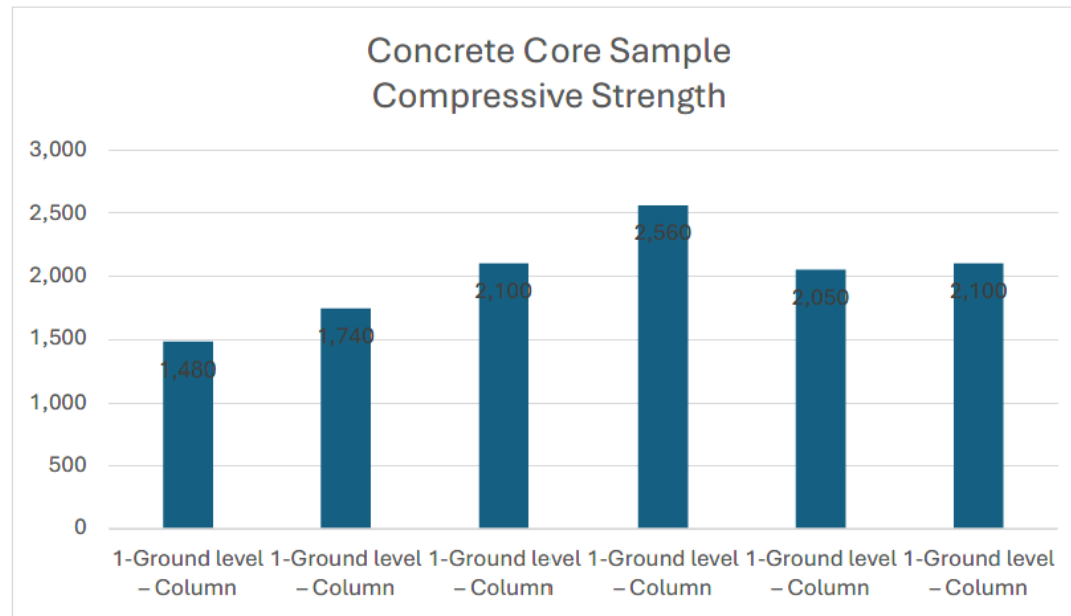

Figure 9. Roof-Framing-to-Stud Connection with Single Hurricane Tie



# Concrete Strength

- Ability to withstand pressure before breaks or fails
- Low compressive strength concrete is more prone to cracking and spalling
- Can lead to structural failure and compromised stability



The Concrete compressive strength ranged from 1,480 to 2,560 PSI. Per Florida Building Code the concrete strength should be 5,000 PSI.

# Concrete Strength

- Extracted core samples confirm a low-density, deteriorated concrete matrix, consistent with **compressive strengths well below** the Florida Building Code–required 5,000 PSI.



The Concrete compressive strength ranged from 1,480 to 2,560 PSI. Per Florida Building Code the concrete strength should be 5,000 PSI.

# Concrete Testing

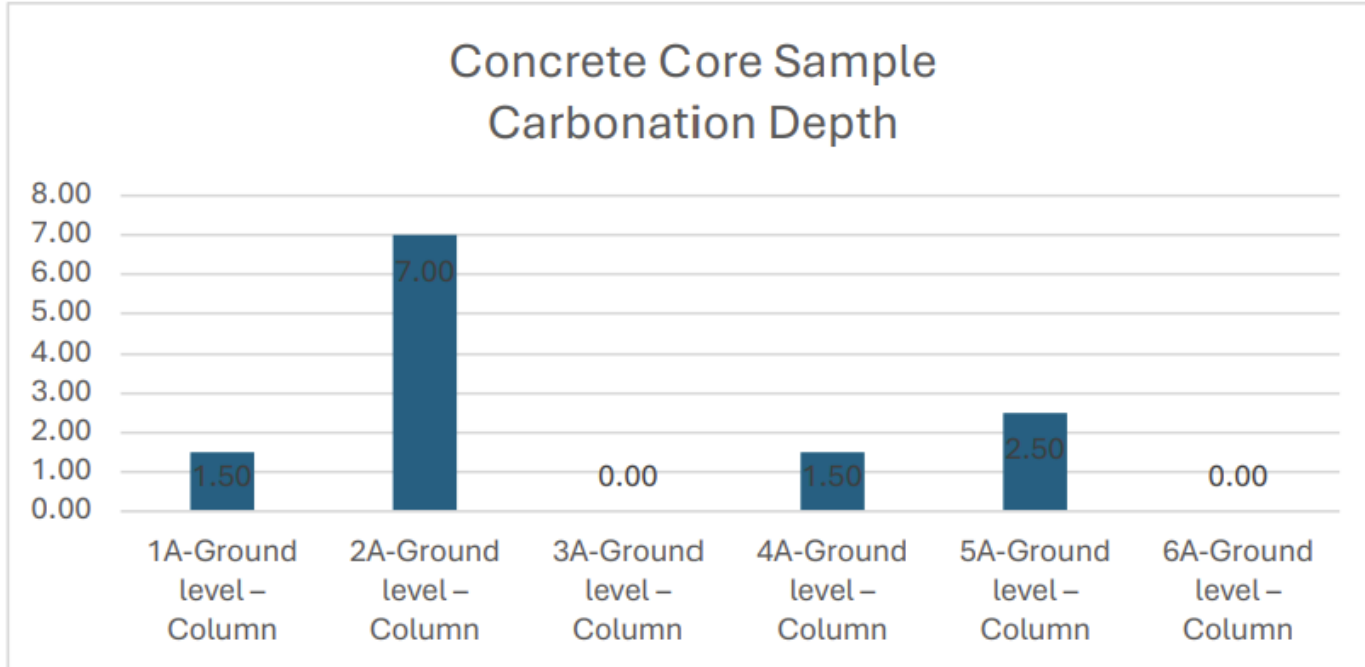

- Depth of carbonation is measured from the surface of the concrete
- Carbonation exposes the rebars to corrosion
- Carbonation is extensive and is as high as 7.00"

# Concrete Testing

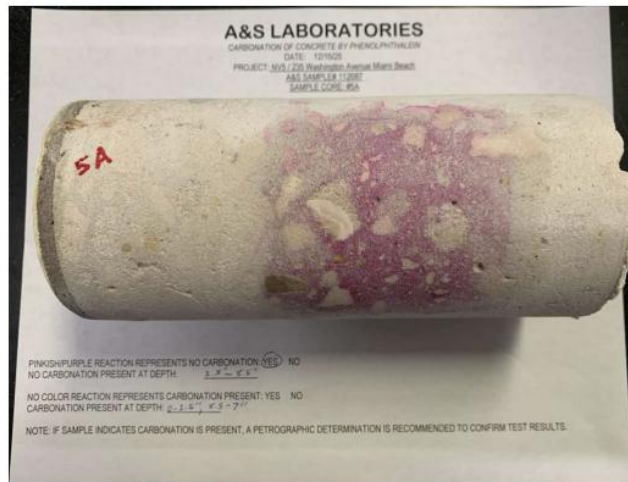
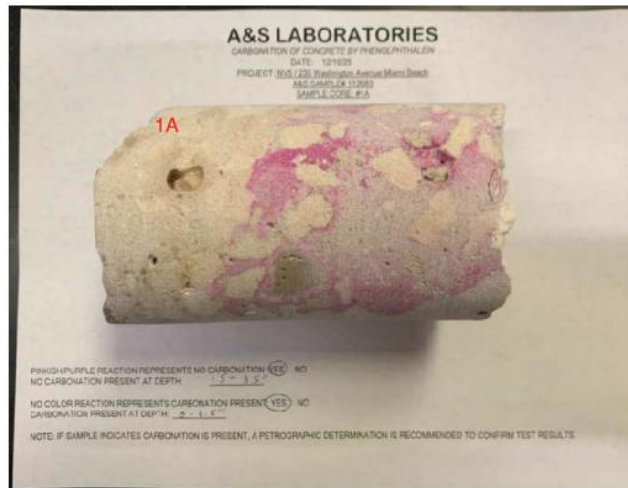

- One-third of samples show carbonation extending beyond the typical depth of reinforcing steel in concrete (>2 inches)
- Another one-third of samples are at or approaching the depth where reinforcing steel is located ( $\approx 1.5$  inches)
- This indicates that much of the structure has lost or is losing protection against steel corrosion, as **carbonation has reached or passed the reinforcing steel**

# Concrete Testing

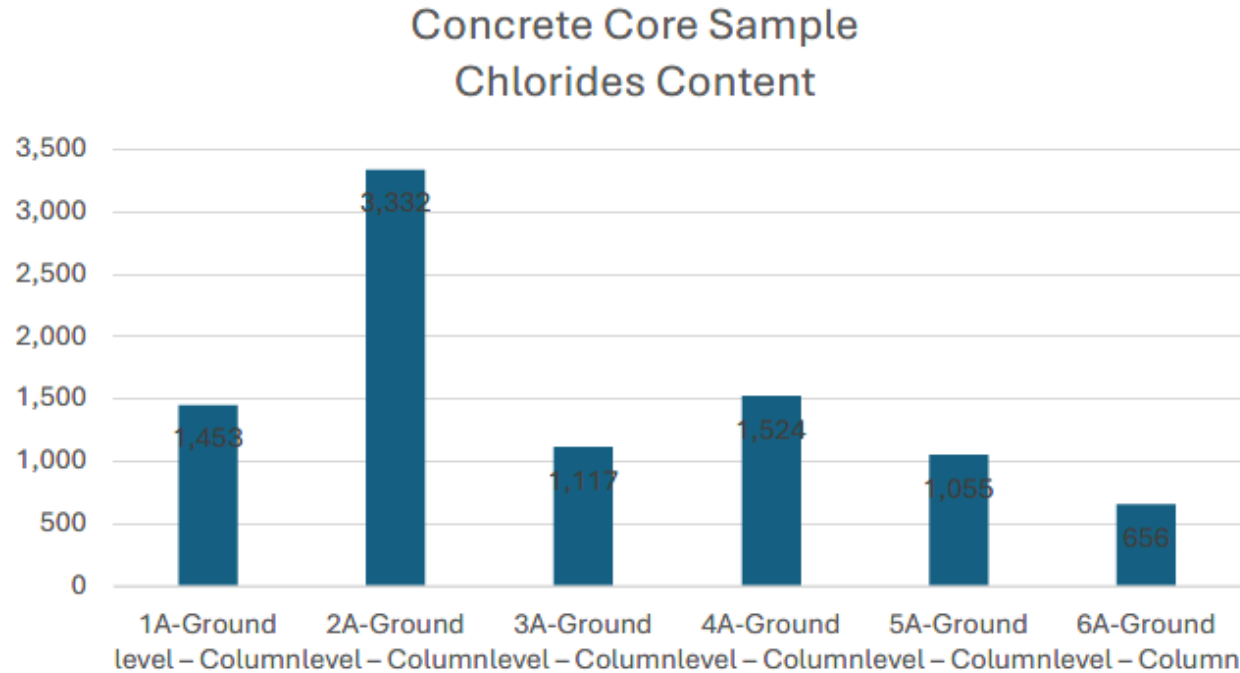

- Chloride exposure reduces alkaline protection of reinforcing steel
- Chloride-ion concentrations ranged from 656 to 3,332 ppm
- Values **exceed** the typical U.S. threshold range of approximately 263–395 ppm (American Concrete Institute)

# Favorable Staff Recommendation

The perimeter design includes a seven-foot aluminum picket fence with solid aluminum gates, consistent with the fence at the abutting school. Benches are proposed within the open space area, which is proposed to be surfaced with a pervious artificial turf system (TigerTurf Everglade Spring Pro), striped to accommodate two mini soccer fields.

Staff is supportive of the applicant's proposal for the re-use of the site, as it provides a desirable enhancement for the basecamp 305 school. To address the scale and fabric of the existing structure, in relation to the urban form of the immediate area, staff recommends that the applicant further study the portion of the perimeter fencing facing Washington Avenue and develop an architectural expression that is inspired by the design of the original structure on site. This can be developed as a revision to the front part of the perimeter fence, or by enhancing the open space amenities.

Staff can work with the project architect to develop this portion of the project, prior to issuance of a building permit for the perimeter fence. However, should the board prefer to review and approve the design of this portion of the project, it is recommended that the perimeter fence portion of the application be continued to the May Historic Preservation Board meeting.

## **RECOMMENDATION**

In view of the foregoing analysis, staff recommends the application be **approved**, subject to the conditions enumerated in the attached draft Order, which address the inconsistencies with the aforementioned Certificate of Appropriateness criteria.

# Historic Plaque

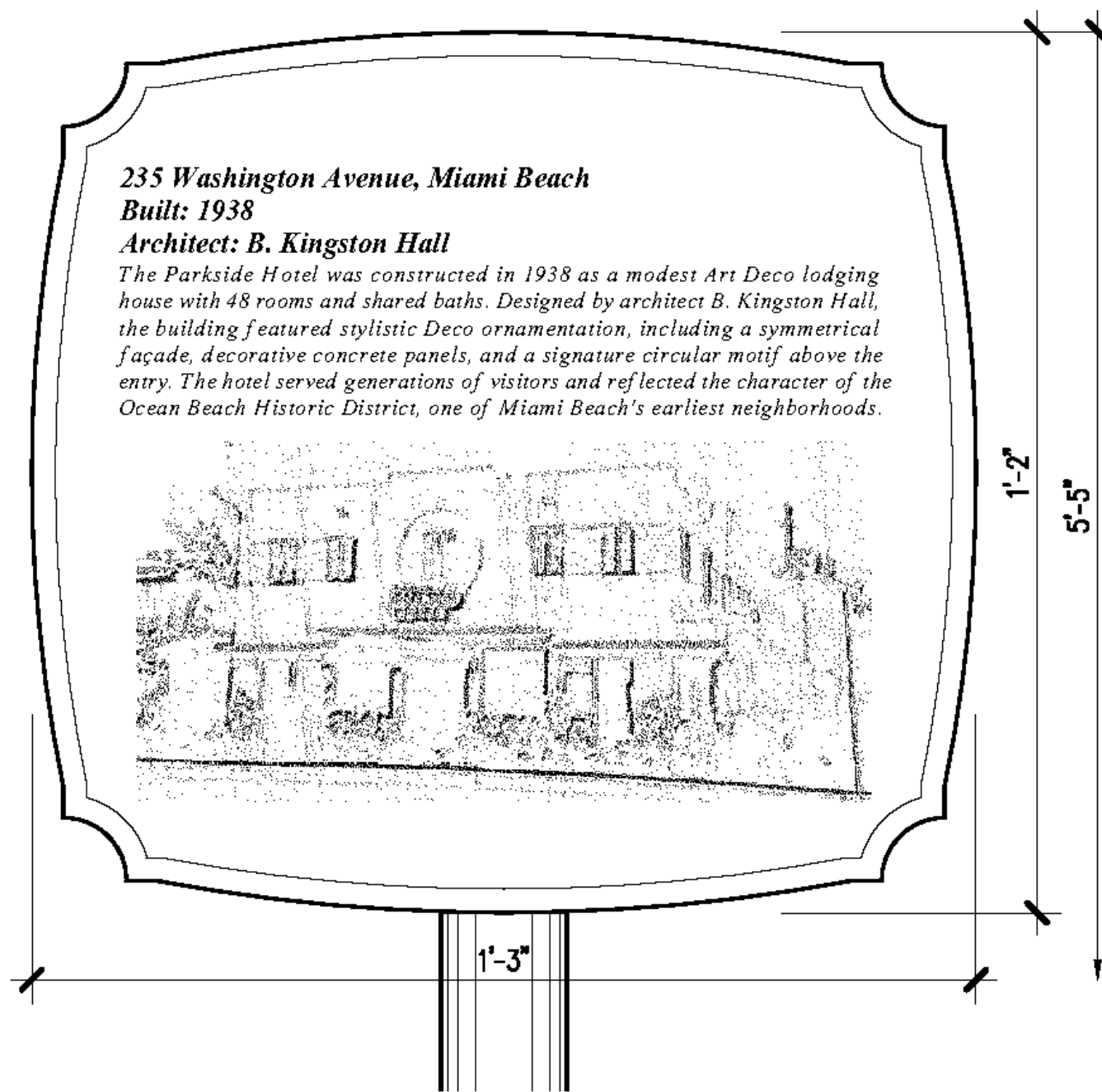

# Original Bungalow: 313 Meridian Avenue

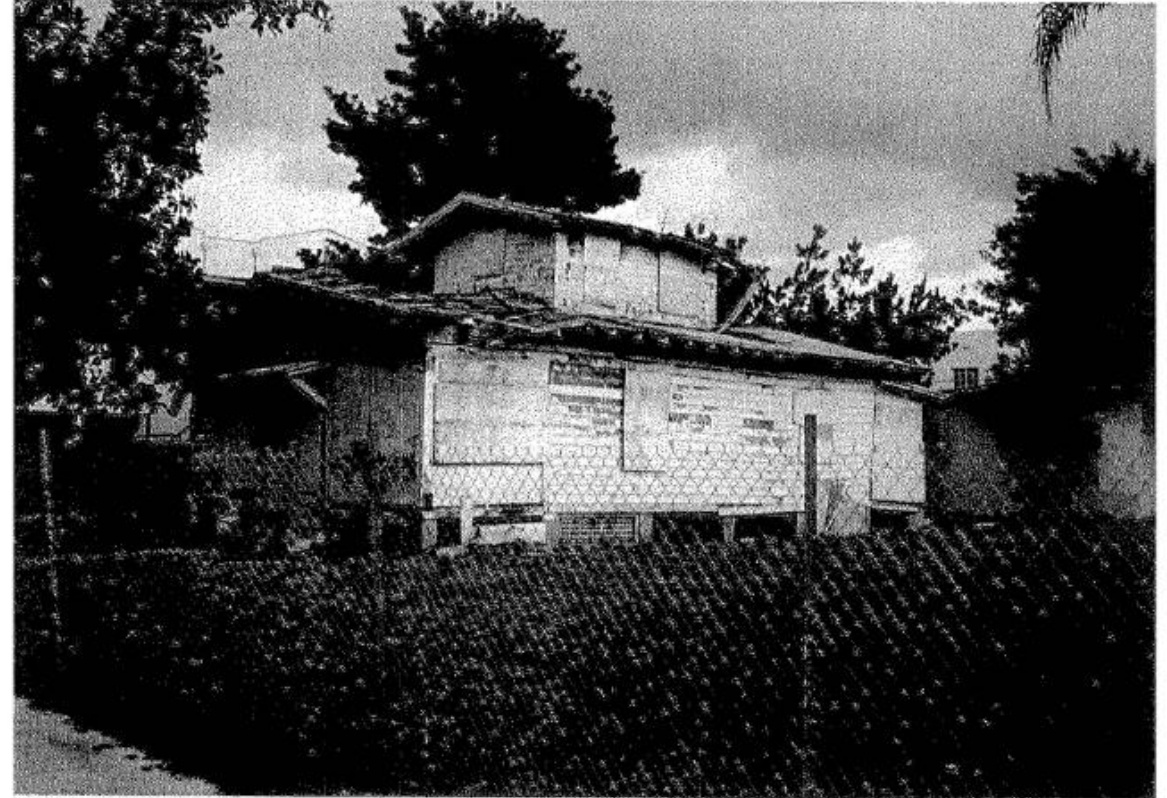
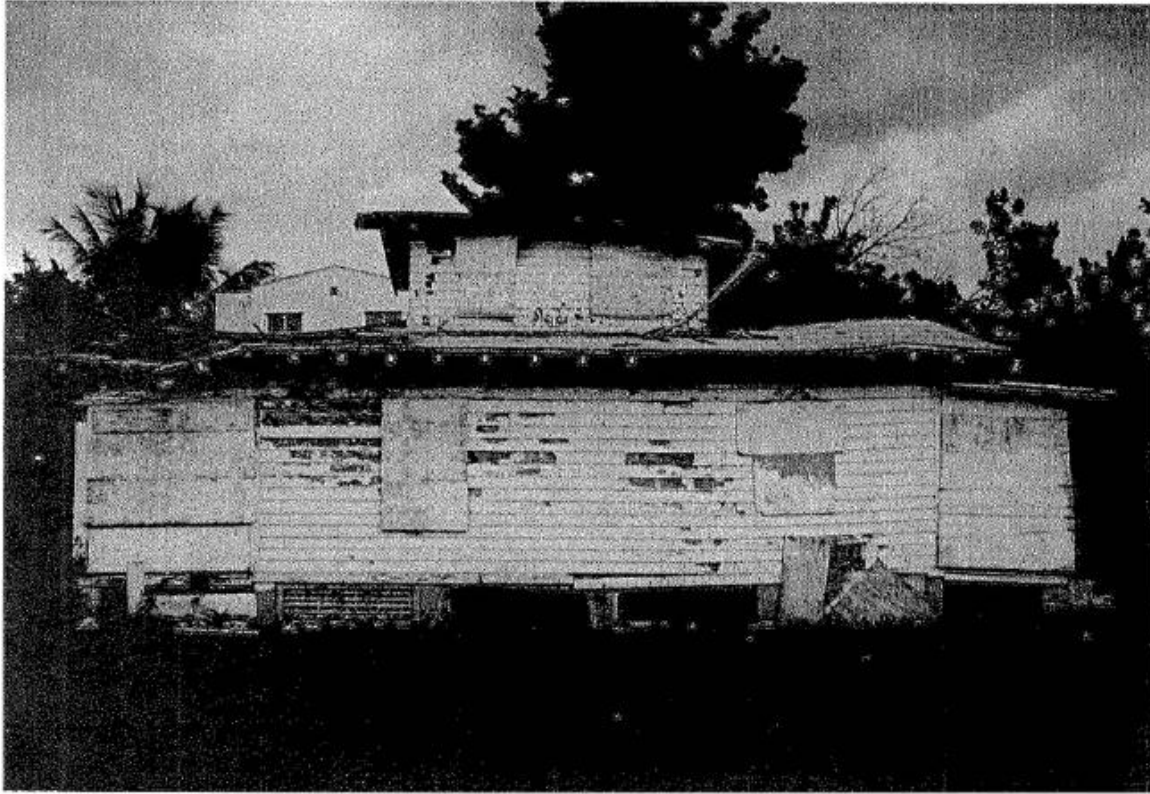

# 2008 HPB Order - File No. 5911

Page 2 of 4  
HPB File No. 5911  
Meeting Date: June 10, 2008

- a. The tenting of the existing structures for termites and other pests shall be required, prior to the issuance of a demolition permit. All domesticated animals, including ferret cats and dogs, shall be humanely removed prior to any tenting.
  - b. The historic wood bungalow structure shall be fully replicated on the site to its original design, based on available historic documentation and measured drawings, at the earliest feasible time, but no later than the commencement of construction of any approved new development project for the entire property, subject to the review and approval of staff.
  - c. The replicated historic bungalow shall be constructed as a fully independent building, complete with its own electrical, plumbing and mechanical system, which may be incorporated as a part of a major development project for the site. No other use of the property other than the bungalow shall be permitted until such time as the Historic Preservation Board approves a larger development project.
  - d. The location of the replicated bungalow shall be subject to review and approval of the Historic Preservation Board.
  - e. The Historic Preservation Board (HPB) or the Planning Director shall retain the right to call the owners or operators back before the HPB, at the expense of the owners or operators, to present progress reports on the replication of the bungalow, as well as any progress in the development of a new project for the balance of the subject property, as deemed necessary.
2. An historic analysis of the existing bungalow structure on the site, inclusive of a photographic and written description of its history and evolution as well as measured drawings of its floor plan, roof plan, and all four exterior elevations, shall be submitted to and approved by staff, prior to the issuance of a Demolition Permit.

# 2014 Supplemental HPB Order - File No. 5911

Applicant's Request. The Applicant hereby requests the modification of the Order in File 5911 in order to remove the requirement to replicate the former bungalow structure and instead allow the Applicant to honor the design and location of the former bungalow as depicted on the submitted plans.

Conclusion. The Applicant is excited to bring an exciting new development to lower Meridian Avenue. The modification of the Order in File No. 5911 will allow the proposed development to honor the former bungalow without replication. We look forward to your recommendation on our application. If you have any questions or comments, please call me at 305-377-6229.

Sincerely,  
  
Graham Penn

cc: Camilo Miguel  
Eduardo Otero  
Christina Cuervo  
Rene Gonzalez, AIA  
Michael Larkin, Esq.



Page 2 of 4  
HPB File No. 5911  
Meeting Date: September 9, 2014

the following conditions are met:

1. Revised elevation, site plan and floor plan drawings shall be submitted to and approved by staff; at a minimum, such drawings shall incorporate the following (conditions stricken below are no longer applicable to the subject property):
  - a. The tenting of the existing structures for termites and other pests shall be required, prior to the issuance of a demolition permit. All domesticated animals, including ferrel cats and dogs, shall be humanely removed prior to any tenting.
  - b. ~~The historic wood bungalow structure shall be fully replicated on the site to its original design, based on available historic documentation and measured drawings, at the earliest feasible time, but no later than the commencement of construction of any approved new development project for the entire property, subject to the review and approval of staff.~~
  - c. ~~The replicated historic bungalow shall be constructed as a fully independent building, complete with its own electrical, plumbing and mechanical system, which may be incorporated as a part of a major development project for the site. No other use of the property other than the bungalow shall be permitted until such time as the Historic Preservation Board approves a larger development project.~~
  - d. ~~The location of the replicated bungalow shall be subject to review and approval of the Historic Preservation Board.~~
  - e. ~~The Historic Preservation Board (HPB) or the Planning Director shall retain the right to call the owners or operators back before the HPB, at the expense of the owners or operators, to present progress reports on the replication of the bungalow, as well as any progress in the development of a new project for the balance of the subject property, as deemed necessary.~~

# Louver House: 313 Meridian Avenue



# Louver House: 313 Meridian Avenue



Street View



Entry/Cottage Pavilion



Entry/Cottage Pavilion



Balcony/ Units View

# Louver House: 313 Meridian Avenue



1 COTTAGE PAVILION  
A-2.03 SCALE: N15



2 COTTAGE PAVILION  
A-2.03 SCALE: N15

# Louver House Sculpture: 313 Meridian Avenue



# Park Side Hotel



**1940 Photograph**  
(Miami Public Library Digital Collections)



**1938 Microfilm**

# Architectural Expression Inspired by the Original Structure



# Community Support

BOARD RESOLUTION  
SOUTH OF FIFTH NEIGHBORHOOD ASSOCIATION

Resolution dated March 10, 2026

Concerning SOFNA Meeting of March 5, 2026 and Proposed BaseCamp305 Playground

Dear Historic Preservation Board Members,

At a public meeting of the South of Fifth Neighborhood Association (SOFNA) held on March 5, 2026, the SOFNA Board voted unanimously to **support** Application File No. HPB25-0645 before the Historic Preservation Board related to 235 Washington Avenue.

SOFNA supports the proposal to create an attractive open space that will serve as a much-needed recreational area for the students of the BaseCamp305 School. Our support is based on the attractive architectural plans presented and the findings of the engineer's structural report confirming the poor condition of the existing building at this site. SOFNA believes that the proposed recreational open space will not only be a healthy and positive benefit for the students at the adjacent BaseCamp305 School, but will also be a welcome enhancement to the neighborhood.

Sincerely,

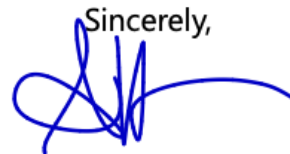

Alyson Herman, Vice President



# Thank You

200 S. Biscayne Boulevard  
Suite 300, Miami, FL 33131

[www.brzoninglaw.com](http://www.brzoninglaw.com)

305.374.5300 office

305.377.6222 fax

[Info@brzoninglaw.com](mailto:Info@brzoninglaw.com)

# Proposed Landscape Plan

PLANT SCHEDULE							
SYMBOL	CODE	BOTANICAL / COMMON NAME	SIZE	CONTAINER	CANOPY	QTY	REMARKS
<b>LOT TREE</b>							
	CDI	Coccoloba diversifolia / Pigeon Plum	2" CAL; 12" HT x 6" SPD.; MIN.	Container	8'	2	
	PDI	Pimenta dioica / Allspice Tree	2" CAL; 12" HT x 6" SPD.; MIN.	Container	8'	2	
SYMBOL	CODE	BOTANICAL / COMMON NAME	SIZE	CONTAINER		QTY	REMARKS
<b>SHRUBS</b>							
	BD	Baccharis dioica / Broombush	18"-24" HT. MIN.	Pot		11	Native - Lot Shrub
	BL	Byrsonima lucida / Key Locustberry	18"-24" HT. MIN.	Pot		12	Native - Lot Shrub
	CD	Croton discolor / Croton	18"-24" HT. MIN.	Pot		8	Native - Lot Shrub
	HB	Heterosavia bahamensis / Maidenbush	18"-24" HT. MIN.			14	Native - Lot Shrub
	TE	Tripsacum floridana / Dwarf Fakahatchee Grass	18"-24" HT. MIN.	Pot		14	Native - Lot Shrub
<b>LARGE SHRUBS</b>							
	CC	Capparis cynophallophora / Jamaica Caper	6' HT MIN x 4' SPD MIN.	Pot		4	Native
	EA	Eugenia axillaris / White Stopper	6' HT MIN x 4' SPD MIN.	Pot		2	Native
	ER	Eugenia rhombea / Red Stopper	6' HT MIN x 4' SPD MIN.	Pot		2	Native
SYMBOL	CODE	BOTANICAL / COMMON NAME	SIZE	CONTAINER	SPACING	QTY	REMARKS
<b>GROUND COVERS</b>							
	MS	Microsorium scolopendria / Wart Fern	1 gal.	Pot	36" o.c.	15	

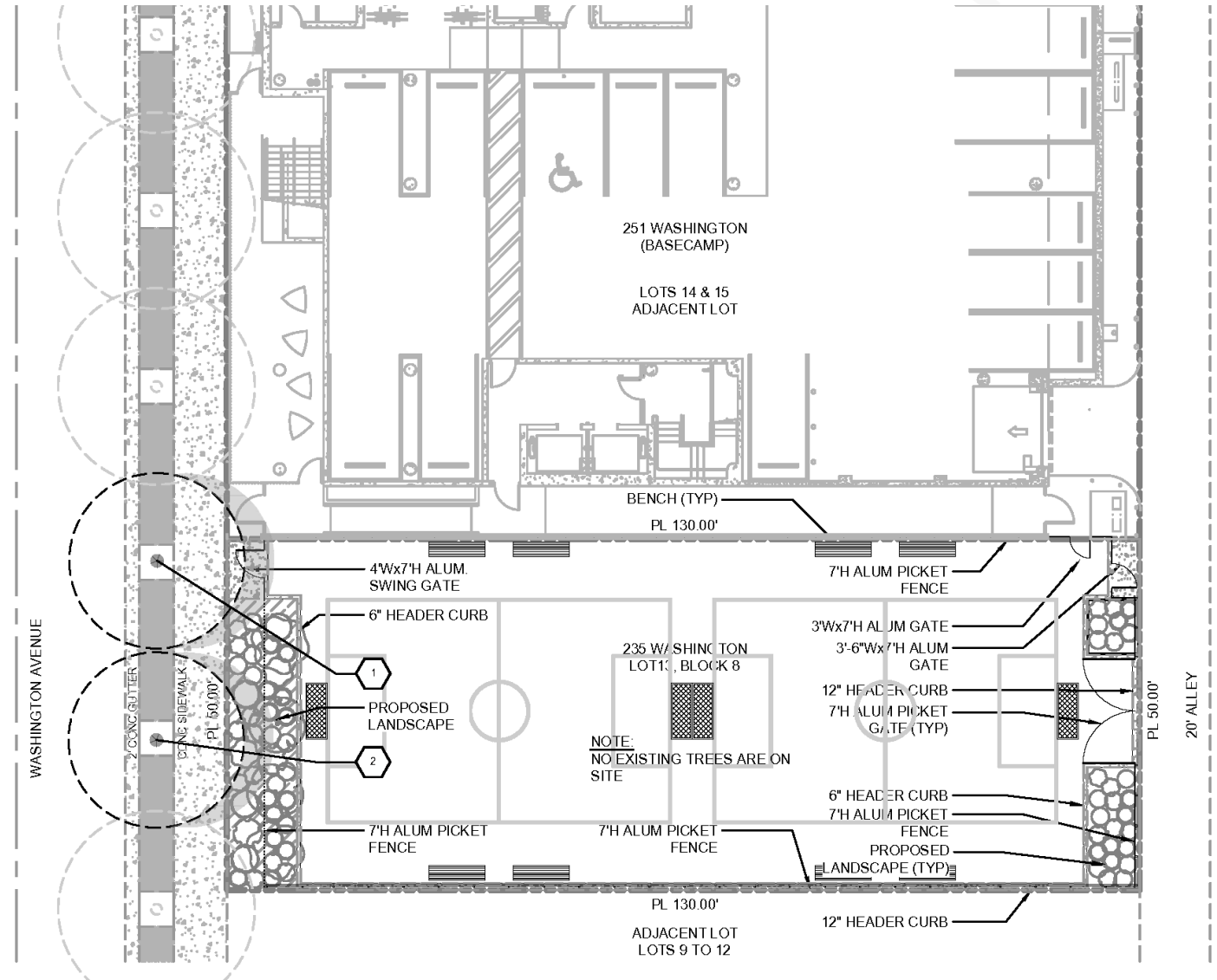

# Examples of Bracing Façade Retention



**Richmond and South Seas Bracing**



**Collins Park Bracing**



**Kaskades Bracing**



**Collins Park Bracing**

# Shoring Fully Retained/Replicated Front Façade

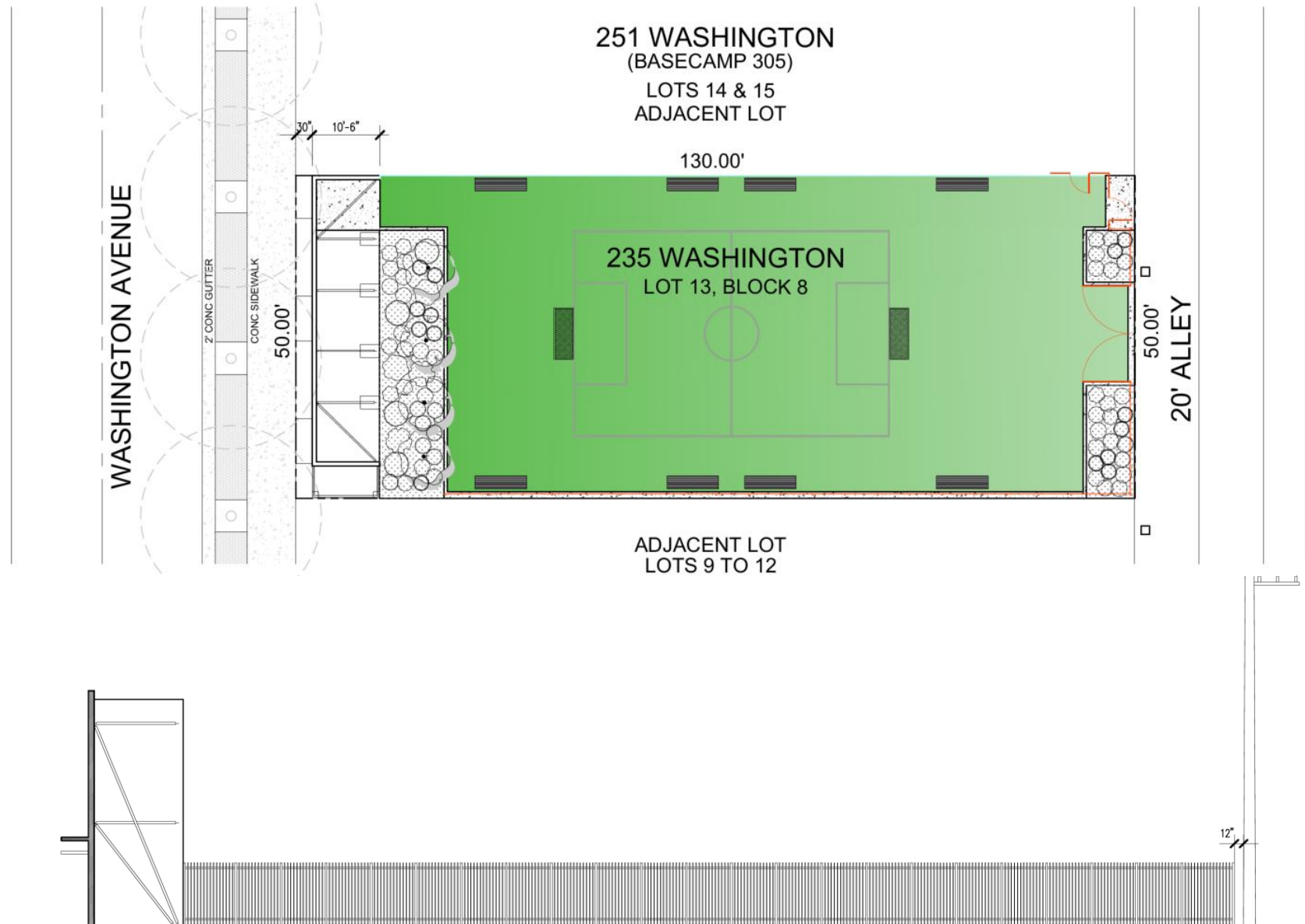

# Power Line Proximity



# Power Line Safety Requirements Restrict Rear Demolition

OSHA Standard 29 CFR §1926.1408 requires that:

“Determine if any part of the equipment, load line or load (including rigging and lifting accessories), if operated up to the equipment's maximum working radius in the work zone, could get closer than **20 feet to a power line**. If so, the employer must meet the requirements in Option (1), Option (2), or Option (3) of this section, as follows:

Option (1) – Deenergize and ground. “Confirm from the utility owner/operator that the power line has been deenergized and visibly grounded at the worksite.”

Option (2) – 20-Foot Clearance: “Ensure that no part of the equipment, load line, or load (including rigging and lifting accessories), gets closer than 20 feet to the power line by implementing the measures specified in paragraph (b) of this section.

Option (3) – Table A Clearance: “Determine the line's voltage and the minimum approach distance permitted under Table A (see §1926.1408)... Determine if any part of the equipment, load line or load (including rigging and lifting accessories), while operating up to the equipment's maximum working radius in the work zone, could get closer than the minimum approach distance of the power line permitted under Table A. If so, then the employer must follow the requirements in paragraph (b) of this section to ensure that no part of the equipment, load line, or load (including rigging and lifting accessories), gets closer to the line than the minimum approach distance.”

Voltage (nominal, kV, alternating current)	Minimum clearance distance (feet)
up to 50	10
over 50 to 200	15
over 200 to 350	20
over 350 to 500	25
over 500 to 750	35
over 750 to 1,000	45
over 1,000	(as established by the utility owner/operator or registered professional engineer who is a qualified person with respect to electrical power transmission and distribution).



# Power Line Safety Requirements Restrict Rear Demolition



Site Elevation (West)

# Power Line Proximity



# Sidewalk Closure



# Raising of the Structure

- To comply with flood elevation requirements, the existing building would need to be raised to a minimum of 10' NGVD, which is a complex process with significant structural and engineering implications.
- Raising the structure would require mechanical lifting of the entire building, and due to its deteriorated structural condition, Youssef Hachem, P.E., has concluded that a successful lift cannot be guaranteed and presents substantial risk.

# Step 1: Cut Building From Foundation

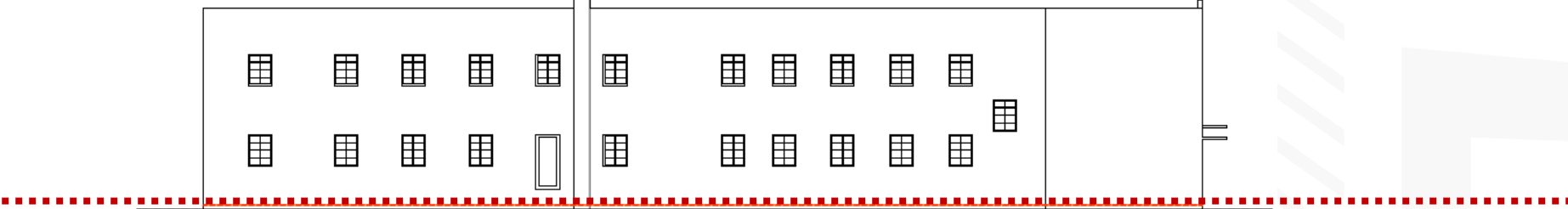

North Elevation

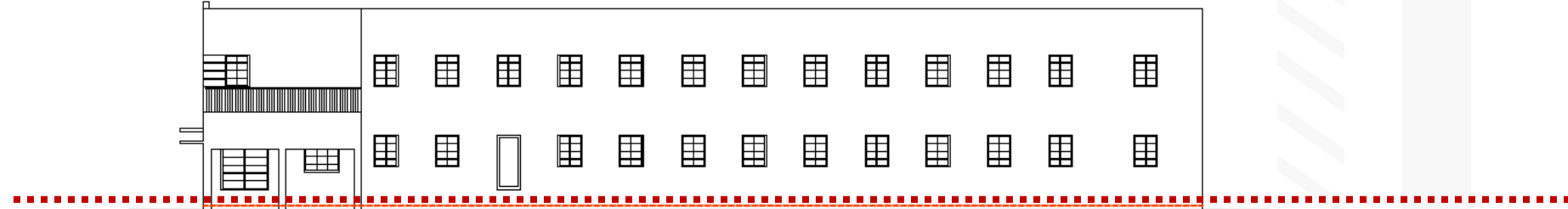

South Elevation

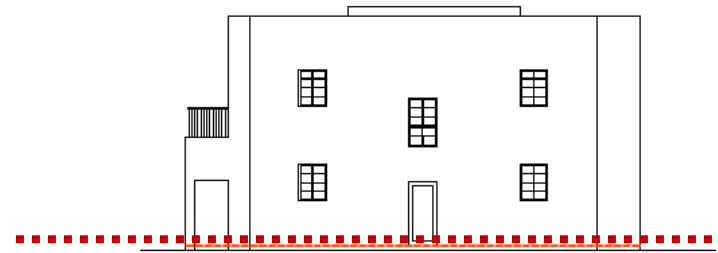

East Elevation (Alley)

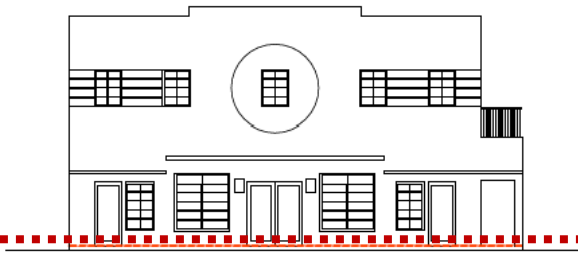

West Elevation (Washington Ave)



# Step 2: Add Reinforcement, Saw-Cut Wall at 32" on Center, Install Rebar, and Pour Concrete

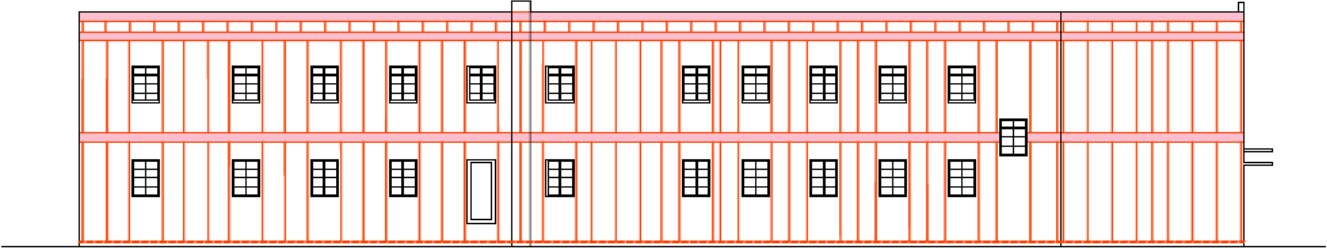

North Elevation

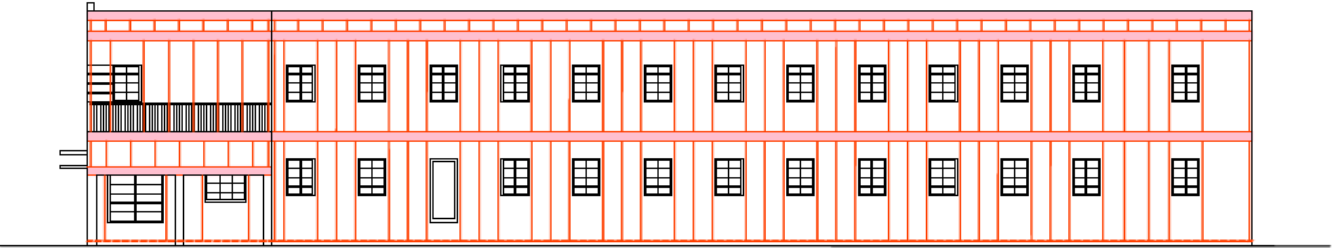

South Elevation

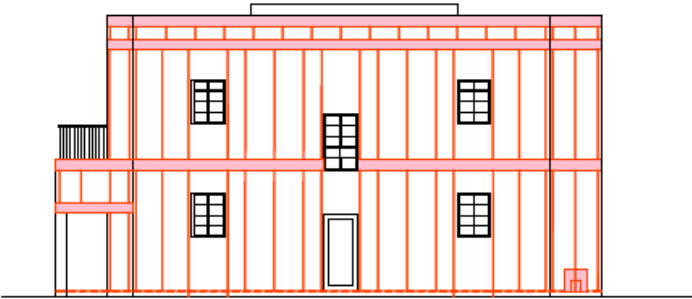

East Elevation (Alley)

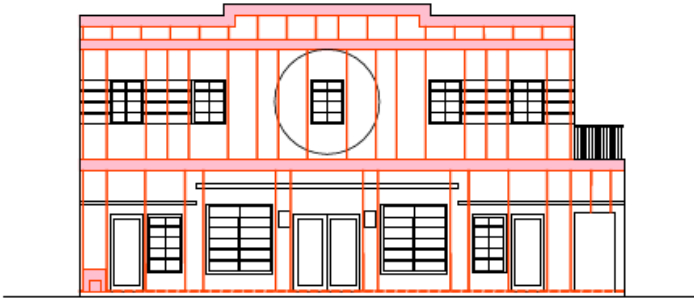

West Elevation (Washington Ave)



# Step 3: Add 2' x 2' Openings to Access the Beams at 5' Intervals

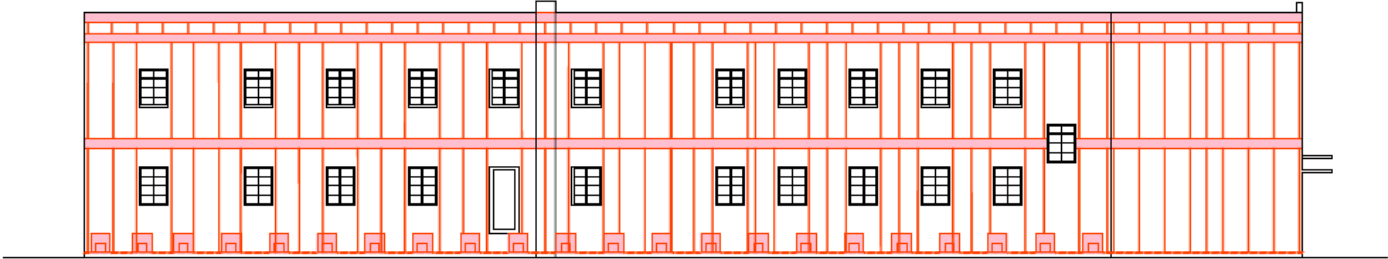

North Elevation

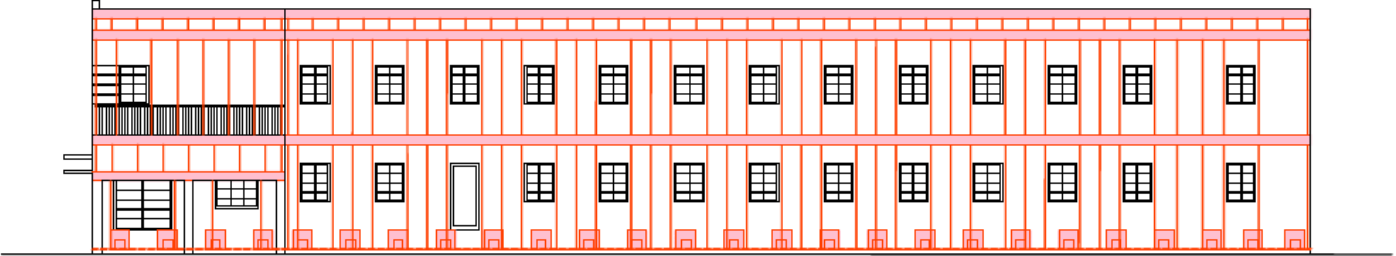

South Elevation

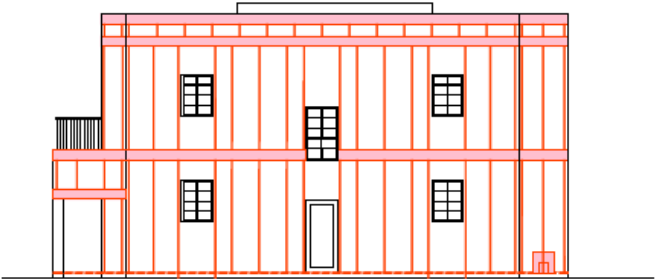

East Elevation (Alley)

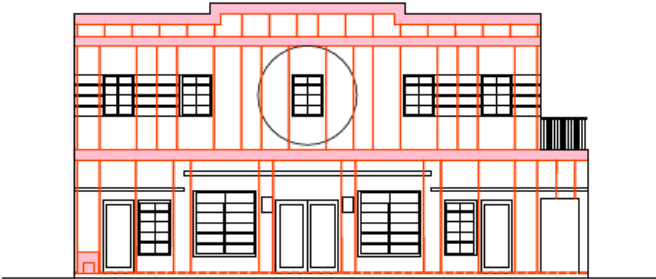

West Elevation (Washington Ave)



# Saw Cutting, Rebar Installation, and Openings Throughout

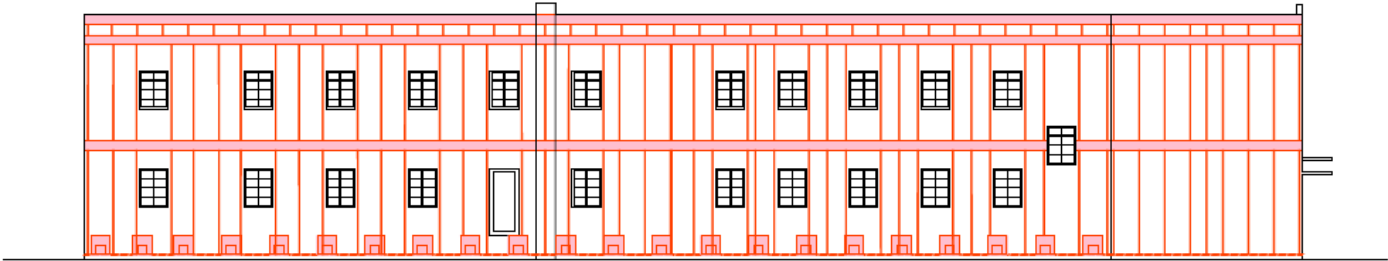

North Elevation

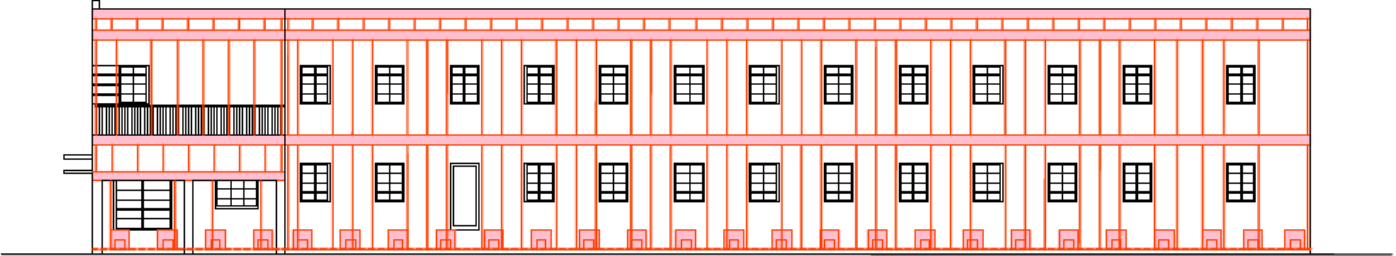

South Elevation

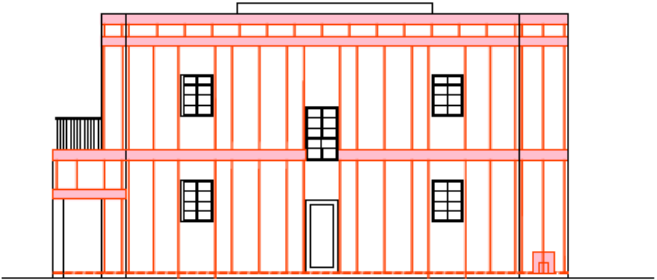

East Elevation (Alley)

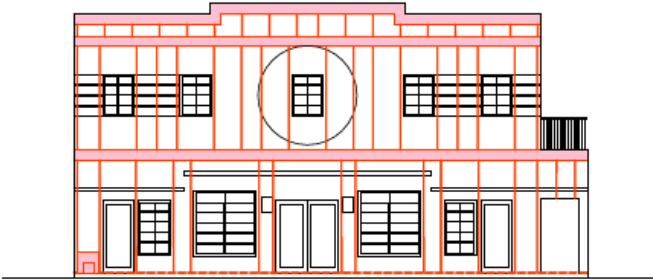

West Elevation (Washington Ave)



# Structural Conclusions

- Based on original construction methods and significant damage:
  - Existing first finished floor elevation (6.1' NGVD) is below the FEMA flood elevation
  - Extensive interior and exterior demolition needed
  - Weak concrete that is exposed to corrosion
  - The structural system components, including foundations, load-bearing walls, and concrete columns, are compromised and cannot support the loads imposed on it
  - Raising the structure would require mechanical lifting, and successful lifting cannot be guaranteed due to the deteriorated structural condition.

# Proposed Elevation: Washington Avenue

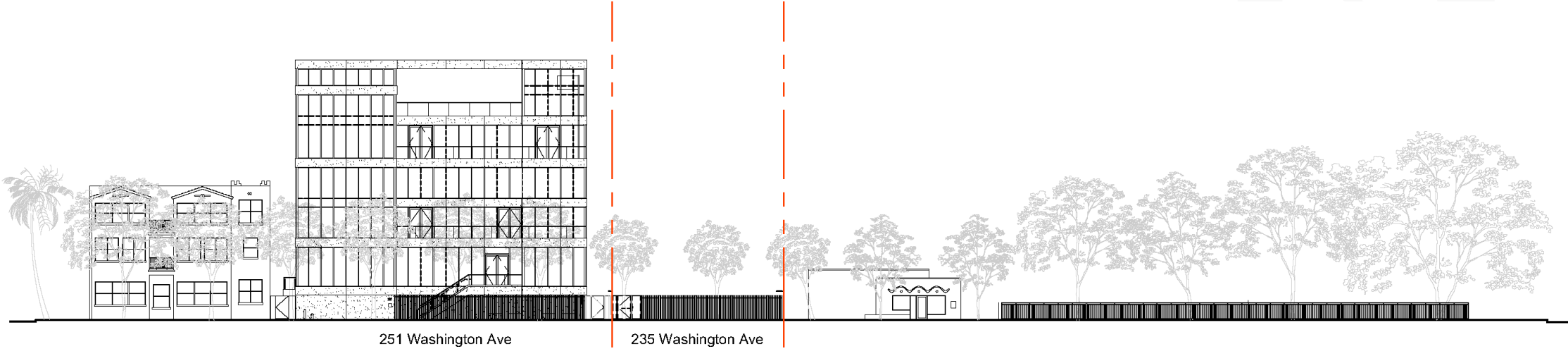

# Understory Plan

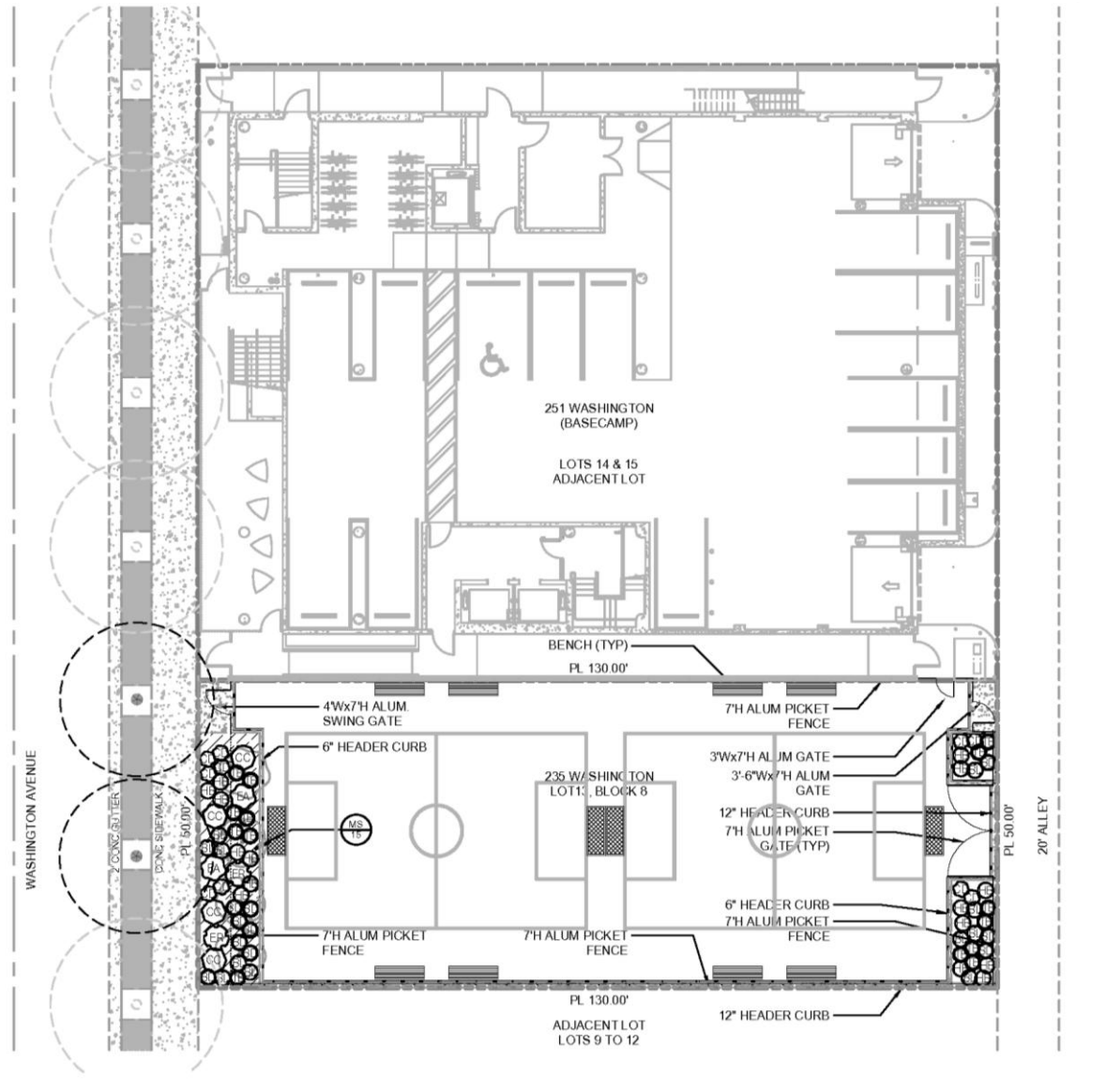

# Canopy Plan

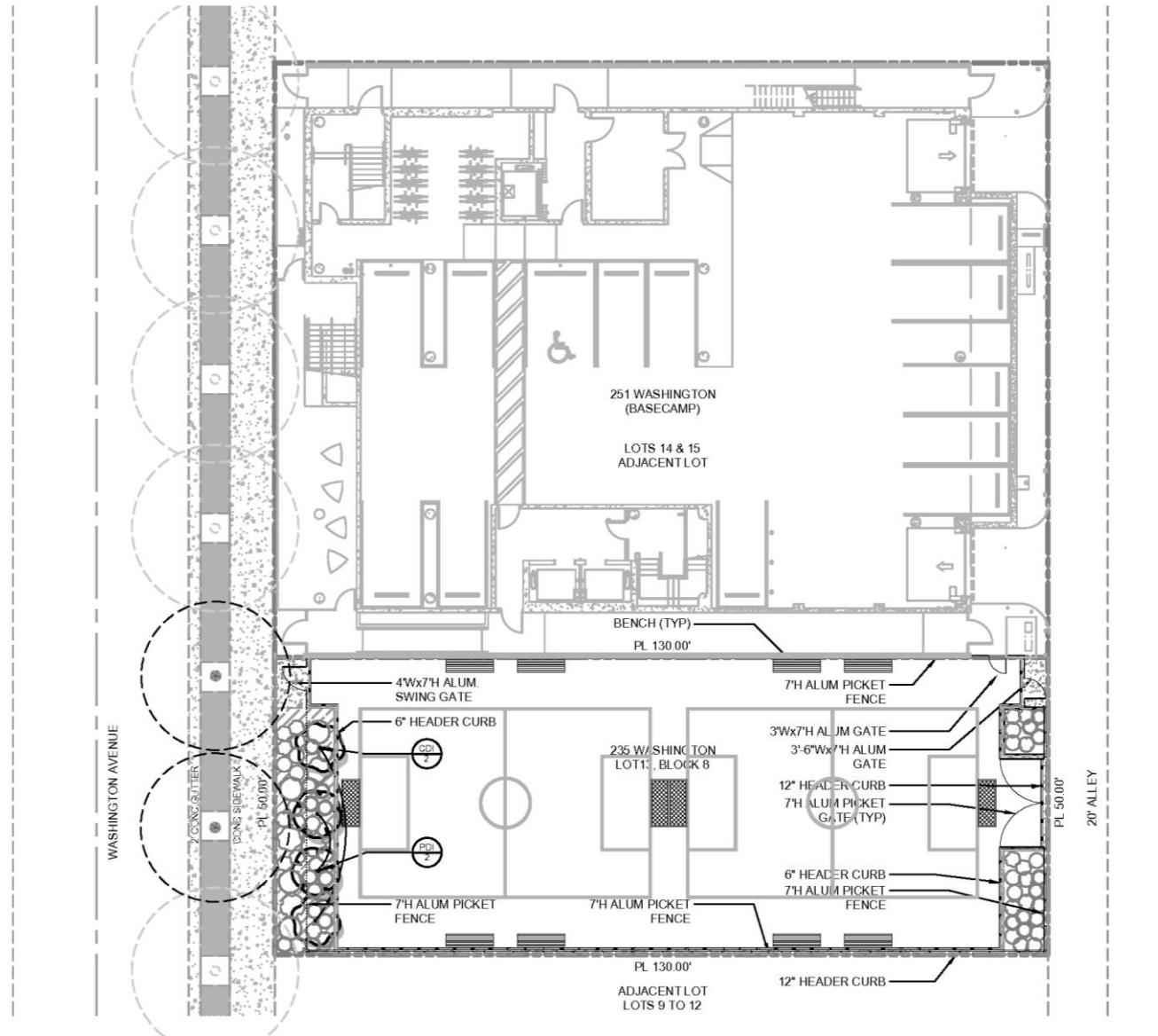

# Tree Disposition Plan



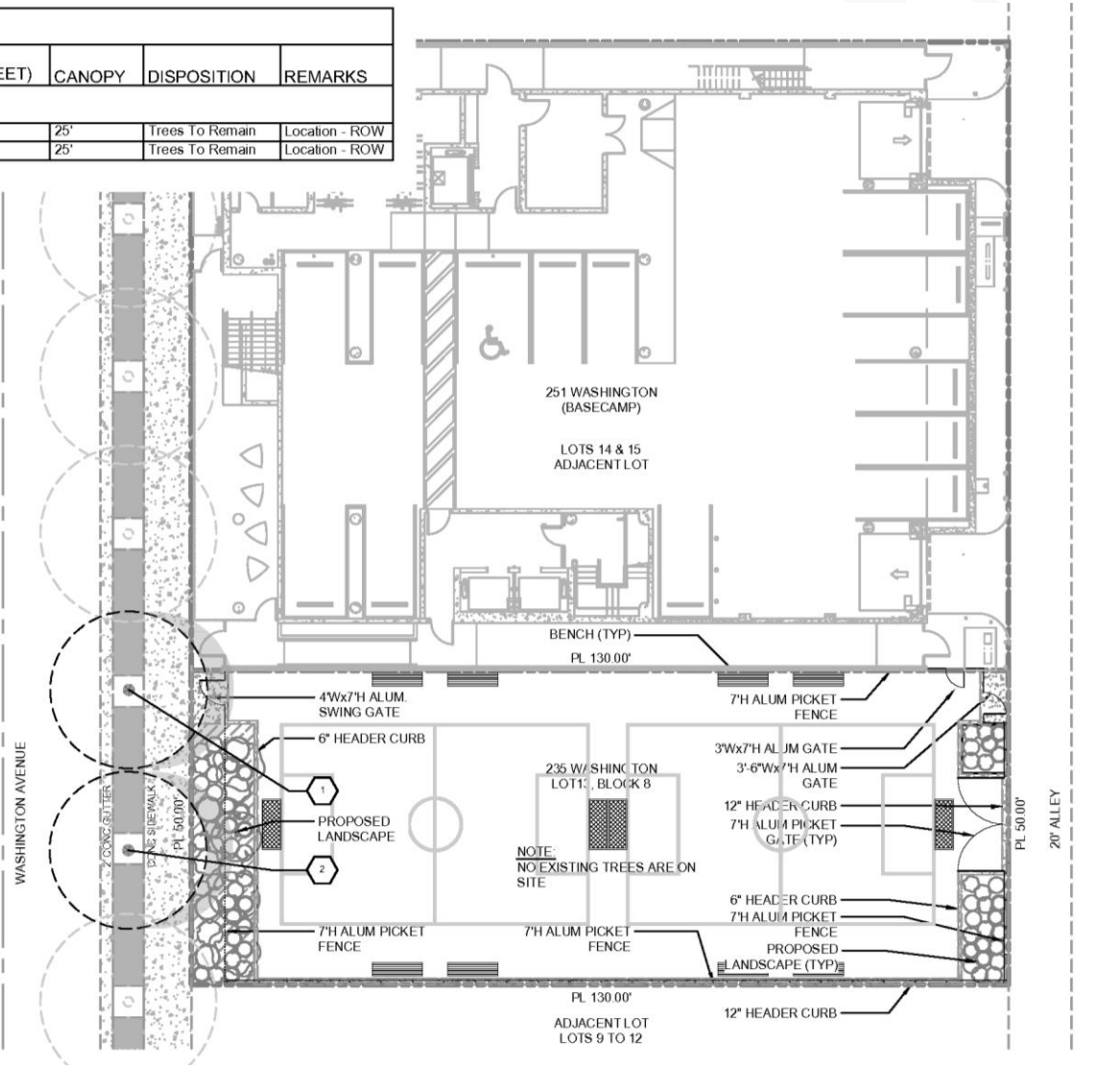

TREE DISPOSITION SCHEDULE						
CODE	BOTANICAL / COMMON NAME	DBH (INCHES)	HEIGHT (FEET)	CANOPY	DISPOSITION	REMARKS
<b>TREES TO REMAIN</b>						
1	Quercus virginiana / Southern Live Oak	12"	30'	25'	Trees To Remain	Location - ROW
2	Quercus virginiana / Southern Live Oak	12"	30'	25'	Trees To Remain	Location - ROW



# Proposed Recreational Plan

## G1.11 SITE PLAN (PROPOSED)

### Legend

-  PROPERTY LINE
-  PROPOSED ALUMINUM FENCE
-  PROPOSED SOLID ALUMINUM SWING GATES & SIDE PANELS
-  LANDSCAPE AREA  
SEE LANDSCAPE PLANS
-  PERVIOUS ARTIFICIAL TURF  
SEE LANDSCAPE PLANS

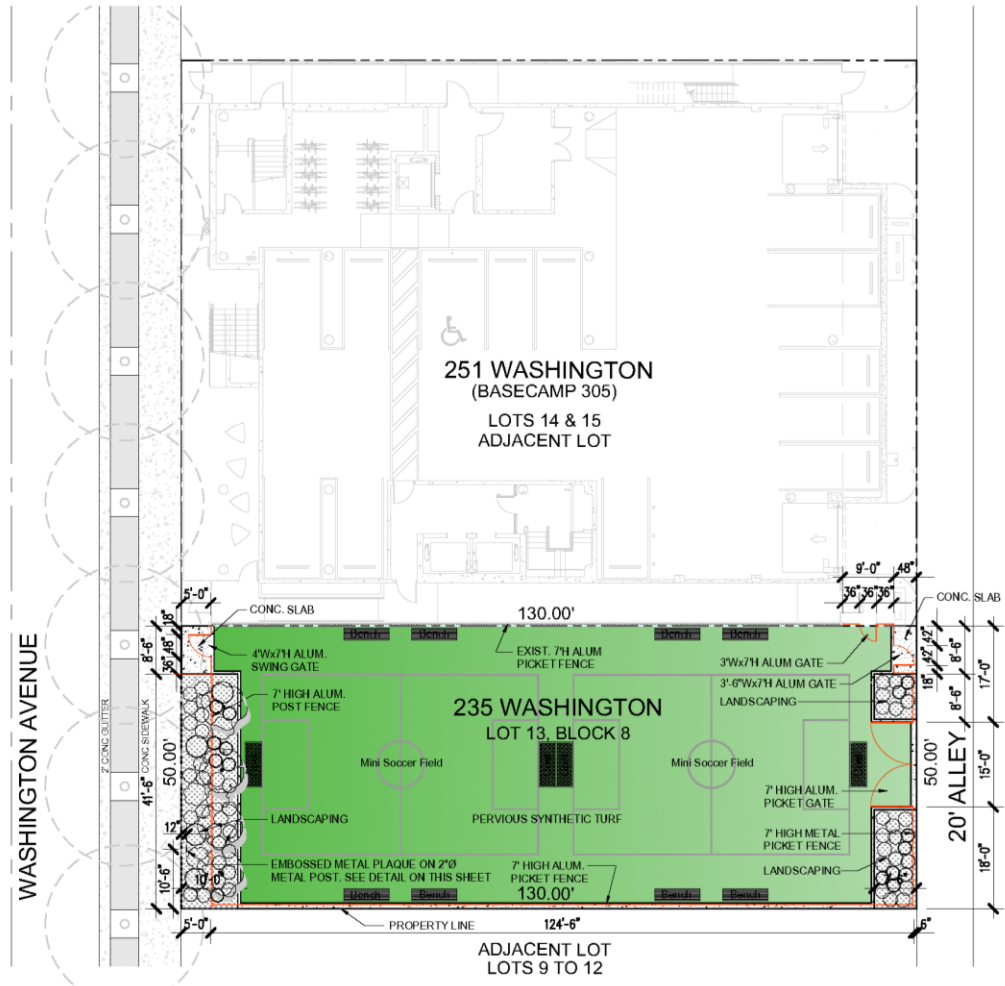
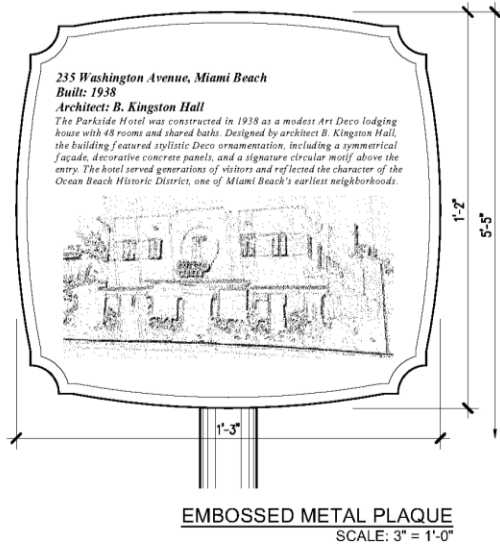

RYAN ALDERMAN  
 ARCHITECT  
 14970 E Falcons Lea Dr.  
 Davie, Florida 33331  
 P: 305.801.9185



N  
 SITE PLAN  
 SCALE: 1" = 20'  
 PROPOSED

