

SITework GENERAL NOTES

1. THE GENERAL CONTRACTOR SHALL BE RESPONSIBLE FOR COORDINATING ALL WORK BY THE SUBCONTRACTORS.
2. CONTRACTOR SHALL VERIFY ALL CONDITIONS AT JOB SITE AND NOTIFY LANDSCAPE ARCHITECT AND GENERAL CONTRACTOR OF DIMENSIONAL ERRORS, OMISSIONS OR DISCREPANCIES BEFORE BEGINNING ANY WORK.
3. CONTRACTOR TO OBTAIN ALL NECESSARY PERMITS PRIOR TO CONSTRUCTION. ALL CONTRACTORS MUST COMPLY WITH PERMIT REQUIREMENTS, LOCAL, STATE AND FEDERAL JURISDICTIONS AND GOVERNING BODIES/AGENCIES RULES AND REGULATIONS AND LAND USE APPROVAL CONDITIONS AT ALL TIMES.
4. WORK PERFORMED WITHOUT APPROVAL OF LOCAL, STATE AND FEDERAL JURISDICTIONS AND GOVERNING BODIES/AGENCIES AND/OR NOT IN COMPLIANCE WITH SPECIFICATIONS AND/OR DRAWINGS IS SUBJECT TO REMOVAL AT CONTRACTOR'S EXPENSE.
5. ALL WORK SHALL CONFORM TO THE APPROPRIATE AGENCIES. CONTRACTOR SHALL VERIFY LOCATION OF ALL EXISTING UTILITIES, LINES AND STRUCTURES PRIOR TO EXCAVATION OR TRENCHING. DAMAGE SHALL BE REPAIRED BY THE CONTRACTOR AT NO COST TO THE OWNER. THE LANDSCAPE ARCHITECT ASSUMES NO RESPONSIBILITY FOR UTILITIES OR STRUCTURES NOT SHOWN ON THE DRAWINGS. CONTRACTOR IS TO VERIFY THE EXACT LOCATION OF UTILITIES PRIOR TO CONSTRUCTION AND NOTIFY THE LANDSCAPE ARCHITECT OF ANY DISCREPANCIES. CONTRACTOR SHALL USE EXTREME CAUTION WHEN WORKING OVER OR NEAR EXISTING GAS AND ELECTRICAL LINES.
6. THE CONTRACTOR SHALL BE RESPONSIBLE FOR RESETTING ALL LAND MONUMENTS DISRUPTED BY CONSTRUCTION ACTIVITIES OR NEGLIGENCE ON THE PART OF THE CONTRACTOR. RESETS SHALL BE PERFORMED UNDER THE SUPERVISION OF A REGISTERED LAND SURVEYOR AND MONUMENT RECORDS MUST BE FILED AS REQUIRED BY STATUTE FOR ALL MONUMENTS.
7. THE CONTRACTOR SHALL TAKE ALL PRECAUTIONARY MEASURES NECESSARY TO PROTECT EXISTING IMPROVEMENTS FROM DAMAGE AND ALL SUCH IMPROVEMENTS AND STRUCTURES DAMAGED BY THE CONTRACTOR'S OPERATIONS SHALL BE REPAIRED OR RECONSTRUCTED SATISFACTORY TO THE LANDSCAPE ARCHITECT AT THE CONTRACTOR'S EXPENSE.
8. ALL BARRICADING AND TEMPORARY TRAFFIC CONTROL DEVICES OR METHODS USED DURING CONSTRUCTION SHALL BE IN ACCORDANCE WITH LOCAL, STATE AND FEDERAL JURISDICTIONS AND GOVERNING BODIES/AGENCIES STANDARDS. PROVIDE ADEQUATE TIME FOR REVIEW AND APPROVAL BY THE ABOVE JURISDICTIONS PRIOR TO COMMENCEMENT.
9. THE LANDSCAPE ARCHITECT IS NOT RESPONSIBLE FOR THE CONSTRUCTION MEANS, METHODS, TECHNIQUES, SEQUENCES UTILIZED OR FOR SAFETY PRECAUTIONS OR PROBLEMS IN CONNECTION WITH THE WORK. THE LANDSCAPE ARCHITECT WILL NOT BE RESPONSIBLE FOR THE CONTRACTOR'S FAILURE TO CARRY OUT THE WORK IN ACCORDANCE WITH THE CONTRACT DOCUMENTS. CONTRACT DOCUMENTS INCLUDE THE CONSTRUCTION DOCUMENT DRAWING SET/TECHNICAL SPECIFICATIONS MANUAL/LASIS.
10. CONTRACTOR TO VERIFY ALL QUANTITIES. IN CASE OF ANY DISCREPANCIES, GRAPHICALLY SHOWN MATERIAL QUANTITIES SHALL TAKE PRECEDENCE.
11. A SYSTEM OF DIAGRAMMATIC SYMBOLS, HATCHES AND NOTATIONS IS USED IN THESE DRAWINGS. REVIEW NOTATIONS CAREFULLY, NOTIFY LANDSCAPE ARCHITECT AND REQUEST CLARIFICATION OF ANY UNCLEAR NOTATION OR DISCREPANCY PRIOR TO COMMENCING WORK.

SITework GENERAL NOTES CONTINUED

1. PROVIDE SLEEVES AS REQUIRED FOR DRAINAGE, IRRIGATION AND ELECTRICAL LINES. IRRIGATION AND ELECTRICAL SLEEVES AND SUBSURFACE DRAINAGE SYSTEMS SHALL BE CONSTRUCTED PRIOR TO PAVING AND LANDSCAPE WORK. UTILITY SLEEVES ARE REQUIRED IN ALL PLANT BEDS ISOLATED BY PAVEMENT OR ANY OTHER STRUCTURES.
2. SPECIAL CONSIDERATION IS GIVEN TO THE DESIGN AND INTENDED RELATIONSHIP BETWEEN ARCHITECTURE, PLANTING AREAS AND PAVING SYSTEMS. PAVEMENT JOINTING, PAVERS, STONE, FINISHES AND GRADES HAVE BEEN STRICTLY COORDINATED IN THE CONTRACT DOCUMENTS. CONSTRUCTION OF THESE SYSTEMS SHALL BE STRICTLY COORDINATED.
3. VEHICLES, EQUIPMENT, AND/OR MATERIALS SHALL NOT BE PARKED OR STORED IN AREAS OF EXISTING VEGETATION, INCLUDING WITHIN THE DRIFLINE OF EXISTING TREES TO REMAIN.
4. CONSTRUCTION WASTE INCLUDING BUT NOT LIMITED TO: PLANT MATERIAL, BUILDING MATERIALS, DEMOLISHED MATERIALS, PACKAGING, LEFTOVER PAINT AND CONCRETE SLURRY SHOULD BE PROPERLY REUSED, RECYCLED, DISPOSED OF LEGALLY OFF-SITE OR IN DESIGNATED WASH-OUT AREAS DETERMINED BY THE GENERAL CONTRACTOR.
5. RECYCLING AND TRASH BINS TO BE PROVIDED ON SITE. SEPARATE BINS FOR CARDBOARD, CO-MINGLED, AND OTHER RECYCLABLE/REUSABLE MATERIALS IDENTIFIED BY THE LOCAL JURISDICTION SHALL BE MAINTAINED. ALL BINS TO BE WILDLIFE-PROOF.
6. ON-SITE FUEL STORAGE FOR CONSTRUCTION EQUIPMENT IS DISCOURAGED. CONSTRUCTION EQUIPMENT USED ON SITE TO BE CHECKED REGULARLY TO ASSURE CONTAMINATION CONCERNS FROM OILS AND GREASES ARE ELIMINATED. NO TOXIC MATERIALS SHALL BE STORED ON-SITE.
7. GENERAL CONTRACTOR TO KEEP ALL ITEMS IMPLEMENTED BY LANDSCAPE ARCHITECT IN PROPER WORKING ORDER THROUGHOUT THE DURATION OF THE PROJECT.
8. THE CONSTRUCTION SITE TO BE INSPECTED ON A MONTHLY BASIS BY LANDSCAPE ARCHITECT AND/OR CIVIL ENGINEER TO ASSURE THAT THE SILT FENCE AND MUD TRACKING PAD ARE PROPERLY IN PLACE AND FUNCTIONING AS DESIGNED.
9. GREEN BUILDING PRACTICES SHALL BE EMPLOYED TO THE EXTENT FEASIBLE. SUCH PRACTICES INCLUDE: CARPOOLING/VANPOOLING TO JOB SITE, MINIMIZING MATERIALS PACKING BEFORE ARRIVAL TO JOB SITE, REDUCING MATERIAL RESOURCE INEFFICIENCIES BY COORDINATING WORK.
10. THE PROJECT LIMIT OF CONSTRUCTION AND ALL EXISTING VEGETATION TO REMAIN IS TO BE CLEARLY DEFINED BY STURDY, WEATHERPROOF FENCING AT A MINIMUM OF FOUR (4) FEET HIGH.
11. WATERPROOFING OF SUBGRADE AND OTHER ARCHITECTURAL SPACES BELOW AND/OR ADJACENT TO IMPROVEMENTS DESIGNED BY THE LANDSCAPE ARCHITECT IS TO BE ADEQUATELY DESIGNED AND DETAILED BY OTHERS TO PERMANENTLY REPEL ALL WATER SOURCES INCLUDING, BUT NOT LIMITED TO: PRECIPITATION, STORM WATER RUNOFF, GROUND WATER, IRRIGATION, ROOF RUNOFF, GROUND WATER, AND PLUMBING LEAKS.
12. STRUCTURAL DESIGN TO SUPPORT IMPROVEMENTS DESIGNED BY THE LANDSCAPE ARCHITECT AND LOCATED ABOVE, BELOW, AND/OR ADJACENT TO SUBGRADE AND OTHER ARCHITECTURAL SPACES IS THE RESPONSIBILITY OF THE STRUCTURAL ENGINEER. THE STRUCTURAL DESIGN SHOULD BE ADEQUATELY DESIGNED TO SUPPORT ALL POSSIBLE LOADS INCLUDING, BUT NOT LIMITED TO: BACKFILL, COMPACTION, PLANTINGS, HARDSCAPES, RETAINING AND FREESTANDING SITE WALLS, AND CONSTRUCTION MATERIALS/EQUIPMENT/ACTIVITY.

SOIL EROSION CONTROL NOTES

1. PRIOR TO BEGINNING ANY EARTH CHANGE, THE CONTRACTOR SHALL INSTALL AND MAINTAIN ALL SESC MEASURES AS SHOWN ON THE CONTRACT DOCUMENTS AND AS REQUIRED BY ANY GOVERNING AGENCIES.
2. ALL SESC MEASURES TO BE MAINTAINED DAILY.
3. THE CONTRACTOR TO CONDUCT ALL EXCAVATION, FILLING, GRADING, AND CLEANUP OPERATIONS IN A MANNER SUCH THAT SEDIMENT, GENERATED BY WIND OR WATER IS NOT DISCHARGED INTO ANY STORM SEWER, DRAINAGE DITCH, RIVER, LAKE, AIR, OR UNDERGROUND UTILITY SYSTEM. STAGE WORK TO MINIMIZE THE AREA OF EXPOSED SOIL, THEREBY REDUCING THE OPPORTUNITY FOR SOIL EROSION.
4. WATER FROM TRENCHES AND OTHER EXCAVATION TO BE PUMPED INTO A FILTRATION BAG TO REMOVE SEDIMENTS FROM THE WATER.
5. NORTH AMERICAN GREEN SC-150 OR EQUIVALENT EROSION CONTROL FABRIC IS REQUIRED ON ALL DISTURBED SLOPES GREATER THAN 3:1 UNTIL PROJECT AREA IS REVEGETATED PER THE PLANTING PLAN.
6. PROVIDE POSITIVE DRAINAGE AWAY FROM ALL STRUCTURES.
7. CONTRACTOR TO PROVIDE ONSITE WATERING TO REDUCE FUGITIVE DUST LEAVING THE SITE DURING CONSTRUCTION.
8. SOIL EROSION CONTROL MEASURES TO BE PROVIDED FOR ALL EXISTING AND PROPOSED DRAINAGE STRUCTURES WITHIN THE PROJECT LIMITS.
9. CONSTRUCTION STAGING AND PHASING SHALL OCCUR, WHERE APPLICABLE, TO MINIMIZE SOIL DISTURBANCE TIME.
10. BEST MANAGEMENT PRACTICES (BMPs) SHALL BE ADJUSTED AS NEEDED TO MEET ANY OTHER UNFORESEEN CONDITIONS.
11. THE GENERAL CONTRACTOR IS RESPONSIBLE FOR INSTALLING A MUD TRACKING PAD/WASHING PAD AT THE CONSTRUCTION ENTRANCES TO MINIMIZE MUD DETACHMENT FROM TRUCK TIRES. 1-1/2 INCH SCREENED ROCK TO BE PLACED ON MIRAFI 140-N FILTER FABRIC. ADDITIONAL CLEAN GRAVEL TO BE ADDED THROUGHOUT THE DURATION OF CONSTRUCTION AS NEEDED.
12. CONTRACTOR SHALL ABIDE BY THE LOCAL, STATE AND FEDERAL JURISDICTIONS AND GOVERNING BODIES/AGENCIES CONSTRUCTION MANAGEMENT PLAN REQUIREMENTS.
13. RESEED AS INDICATED IN SEEDING NOTES.



NIELSEN
Landscape architects

1447 cypress drive, 2
jupiter, FL 33469
561.402.9414

www.nielsenlandarch.com

LOT 10 GARDEN
1100 BAY DRIVE | MIAMI BEACH, FLORIDA 33141

SEAL OF TYLER NIELSEN - LAB07001

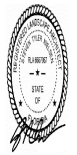

07.02.2025

GENERAL SITE NOTES

DATE	ISSUE
05.07.2023	25% CD
06.21.2023	50% CD
07.09.2023	75% CD
01.25.2024	75% CD
02.28.2024	100% CD
01.13.2025	COORDINATION
07.02.2025	DRS SUBMITTAL

L001

CONTRACTOR QUALIFICATIONS

1. CONTRACTOR MUST BE A LICENSED LANDSCAPE CONTRACTOR.
2. CONTRACTOR MUST HAVE A MINIMUM OF 10 YEARS OF PROVEN EXPERIENCE RELOCATING LARGE SPECIMEN TREES AND PALMS IN SOUTH FLORIDA.
3. CONTRACTOR MUST HAVE PROVEN EXPERIENCE RELOCATING TREES AND PALMS OF THE SAME SPECIES AND SIZE AS THOSE TO BE RELOCATED FOR THE CURRENT PROJECT.
4. CONTRACTOR MUST HAVE A CERTIFIED ARBORIST ON STAFF

CONTRACTOR REQUIREMENTS

1. CONTRACTOR MUST VISIT THE JOB SITE AND INSPECT ALL TREES AND PALMS TO BE RELOCATED AS WELL AS EXISTING SITE CONDITIONS AND RESTRICTIONS PRIOR TO PREPARING BID.
2. CONTRACTOR MUST VERIFY AND ENSURE THAT ALL TREES AND PALMS IDENTIFIED ON THE PLANS AND THOSE TAGGED ON THE JOB SITE CORRESPOND AS TO NUMBER AND DESCRIPTION. ANY DISCREPANCIES MUST BE BROUGHT TO THE ATTENTION OF THE LANDSCAPE ARCHITECT IMMEDIATELY, PRIOR TO PREPARING BID.
3. CONTRACTOR MUST CONDUCT ALL WORK ASSOCIATED WITH RELOCATION AND MAINTENANCE OF TREES AND PALMS TO BE RELOCATED. NO WORK IS TO BE SUBCONTRACTED WITHOUT PRIOR WRITTEN CONSENT OF THE OWNER AND/OR LANDSCAPE ARCHITECT.
4. CONTRACTOR MUST DESIGNATE A COMPETENT, ENGLISH-SPEAKING SUPERVISOR OR FOREMAN OVERSEE AND DIRECT ALL RELOCATION AND MAINTENANCE ACTIVITIES AS OUTLINED IN THESE SPECIFICATIONS.
5. CONTRACTOR MUST SCHEDULE ROOT PRUNING TO PROVIDE THE MAXIMUM POSSIBLE TIME FOR NEW ROOT GROWTH. EVEN TREES AND PALMS THAT TYPICALLY DO NOT REQUIRE LONG (OR ANY) ROOT PRUNING WILL BENEFIT FROM MORE ROOT PRUNING TIME. THEREFORE, ALL TREES AND PALMS TO BE RELOCATED MUST BE ROOT PRUNED. CONTRACTOR MUST PROVIDE A ROOT PRUNE SCHEDULE FOR EACH TREE OR PALM TO BE RELOCATED AS AN ATTACHMENT TO THE BID.
6. CONTRACTOR MUST CALL SUNSHINE 811 TO HAVE ALL UNDERGROUND UTILITIES LOCATED UNDER OR IN THE VICINITY OF THE CURRENT OR FUTURE LOCATIONS OF ALL TREES AND PALMS TO BE RELOCATED PRIOR TO WORK COMMENCING.
7. CONTRACTOR MUST VERIFY WITH THE GENERAL CONTRACTOR THE ABSENCE OF ANY UNDERGROUND CONSTRUCTION OR OBSTRUCTIONS (E.G., BULKHEADS, SEPTIC SYSTEMS, ETC.) IN THE CURRENT AND FUTURE LOCATIONS OF ALL TREES AND PALMS TO BE RELOCATED.
8. CONTRACTOR MUST ALERT THE LANDSCAPE ARCHITECT OF ANY TREES OR PALMS THAT WILL NOT SUCCESSFULLY RELOCATE DUE TO POOR HEALTH PRIOR TO BEGINNING ROOT PRUNING.
9. CONTRACTOR MUST FLAG ALL PROPOSED TRANSPLANT LOCATION FOR THE LANDSCAPE ARCHITECT'S APPROVAL A MINIMUM OF 15 DAYS PRIOR TO RELOCATION.
10. CONTRACTOR MUST ENSURE THAT ALL TREES AND PALMS TO BE RELOCATED ARE INSTALLED AT THE CORRECT GRADE OR ELEVATION, ACCORDING TO THE GRADING PLAN.
11. CONTRACTOR MUST BE SURE THAT ALL ROOT FLARES ARE EXPOSED AFTER RELOCATION.
12. CONTRACTOR MUST REMOVE ALL RESIDUAL ROOTS, STUMPS, AND PORTIONS THEREOF AND BACKFILL PITS FROM WHICH RELOCATED TREES AND PALMS WERE REMOVED WITH CLEAN FILL FULL FLUSH WITH THE SURROUNDING GRADE.
13. CONTRACTOR MUST BE SURE TO REPAIR ANY DAMAGE TO OTHER PLANTS, LAWN, HARDSCAPES, OR NEW CONSTRUCTION WITHIN THE RELOCATION AREA AT CONTRACTOR'S EXPENSE. HARDSCAPES INCLUDE BUT ARE NOT LIMITED TO CURBS, WALKS, ROADS, FENCES, SITE FURNISHINGS, ETC.
14. CONTRACTOR MUST PHOTOGRAPHICALLY DOCUMENT NEW ROOT GROWTH FOLLOWING EACH ROOT PRUNE AND SUBMIT THIS DOCUMENTATION TO THE LANDSCAPE ARCHITECT. THE PURPOSE OF THIS REQUIREMENT IS TO ENSURE THAT SUFFICIENT ROOT GROWTH HAS OCCURRED PRIOR TO THE SECOND AND SUBSEQUENT ROOT PRUNES AND FOLLOWING THE FINAL ROOT PRUNE PRIOR TO RELOCATION.
15. CONTRACTOR MUST INSTALL AND MAINTAIN PROTECTION FENCING AROUND EACH TREE AND PALM TO BE RELOCATED BOTH DURING ROOT PRUNING AND AFTER RELOCATION. PROTECTION FENCING MUST CONSIST OF GALVANIZED WELDED WIRE FABRIC OR PLASTIC MESH ATTACHED TO 4" X 4" POSTS INSERTED AROUND THE PERIMETER OF THE DRIPLENE OF THE TREE OR PALM. PROTECTION FENCING MUST BE PLUMB, TAUT, AND STURDY AT ALL TIMES AND MUST REMAIN IN PLACE THROUGHOUT THE ROOT PRUNING AND WARRANTY PERIODS, OR AS DIRECTED BY THE LANDSCAPE ARCHITECT.
16. CONTRACTOR MUST OBTAIN ALL NECESSARY OR REQUIRED PERMITS FOR THE RELOCATION AND TRANSPORTATION OF THE TREES AND PALMS TO BE RELOCATED.
17. CONTRACTOR MUST GUARANTEE ALL RELOCATED TREES AND PALMS FOR ONE YEAR FROM THE DATE OF RELOCATION TO THE FINAL LOCATION. GUARANTEE MUST INCLUDE TREE HEALTH AND SETTLING.
18. CONTRACTOR MUST PROVIDE ALL MATERIAL NECESSARY TO PERFORM THE WORK COVERED HEREIN, INCLUDING BUT NOT LIMITED TO BACKFILL MATERIAL, PROTECTION FENCING, FLAGGING, ADDITIVES AND SUPPLEMENTS, TEMPORARY IRRIGATION, BURLAP, WIRE, SHRINK WRAP, AND ALL NECESSARY TOOLS AND EQUIPMENT.

TREE ROOT PRUNING SPECIFICATIONS

1. ALL TREES AND PALMS TO BE RELOCATED MUST BE WATERED DAILY FOR AT LEAST 2-3 DAYS PRIOR TO ANY ROOTS BEING CUT TO ENSURE THAT THEY ARE FULLY HYDRATED. EACH WATERING MUST THOROUGHLY SATURATE THE ROOTBALL TO ITS FULL DEPTH.
2. EACH TREE AND PALM MUST THEN BE WATERED EVERY OTHER DAY, NOT RELYING ON RAIN, DURING THE ENTIRE ROOT PRUNING PROCESS EITHER BY A TEMPORARY IRRIGATION SYSTEM OR BY HAND. EACH WATERING MUST THOROUGHLY SATURATE THE ROOTBALL TO ITS FULL DEPTH.
3. TREE AND PALM RELOCATION ACTIVITIES MUST BE SCHEDULED SO THAT REMOVAL AND REPLANTING TAKE PLACE IN THE SAME 24-HOUR PERIOD. NO TREES OR PALMS MAY BE "STOCKPILED" ON SITE OR OFF SITE FOR ANY PERIOD OF TIME. WITHOUT PRIOR WRITTEN APPROVAL OF THE LANDSCAPE ARCHITECT. WHEN ALLOWED, APPROVAL FOR THE METHOD OF "STOCKPIILING" MUST BE OBTAINED FROM THE LANDSCAPE ARCHITECT.
4. ALL DIGGING IN THE ROOT ZONE DURING THE ROOT PRUNE PROCESS MUST BE DONE BY HAND. NO MACHINERY WILL BE ALLOWED. PRUNING OF ROOTS MUST BE DONE BY HAND WITH CLEAN, SHARP TOOLS. DO NOT PAINT CUT ROOTS WITH TREE PAINT OR ANY KIND OF SEALANT.
5. MYCORRHIZA ROOTS (OR EQUIVALENT) MUST BE INCORPORATED INTO THE BACKFILL SOIL PRIOR TO BACKFILLING AS PER MANUFACTURER'S RECOMMENDATIONS.
6. AFTER EACH ROOT PRUNE, EACH SECTION OF ROOTBALL THAT IS PRUNED MUST BE WRAPPED WITH BLACK PLASTIC AND THE TRENCH BACKFILLED WITH ORIGINAL EXCAVATED SOIL. A TREE RING WITH A MINIMUM HEIGHT OF 6" MUST BE CONSTRUCTED 6-12" OUTSIDE THE OUTERMOST EDGE OF THE ROOTBALL AND AROUND THE ENTIRE PERIMETER OF THE ROOTBALL TO DIRECT IRRIGATION WATER AND ANY ADDED SUPPLEMENTS DOWN INTO THE ROOTBALL DURING ROOT REGENERATION.
7. ONCE THE TREE RING IS CONSTRUCTED AFTER EACH ROOT PRUNE, A HIGH-PHOSPHORUS ROOT STIMULANT MUST BE LIBERALLY APPLIED TO THE SURFACE OF THE ROOTBALL AND THOROUGHLY WATERED IN TO ENCOURAGE NEW ROOT GROWTH.
8. PRIOR TO ANY ROOTS BEING CUT, ALL MAJOR ROOTS MUST BE IDENTIFIED TO DETERMINE THE ROOTBALL DIAMETER BASED ON THE RELATIVE LOCATION AND SIZE OF THE ROOTS.
9. MANY TREE RELOCATION SPECIFICATIONS USE "GENERAL RULES" TO CALCULATE MINIMUM ROOTBALL DIAMETER, SUCH AS MULTIPLYING THE DIAMETER AT BREAST HEIGHT (DBH) OF THE TREE BY A FACTOR OF 10 OR ALLOWING A MINIMUM OF 9"-12" OF ROOTBALL FOR EVERY 1" OF TREE CALIPER. OTHERS LIST UNREALISTIC MINIMUM SIZES FOR THE ROOTBALLS OF VARIOUS TREE CALIPERS OR OTHERS LIST UNREALISTIC MINIMUM SIZES FOR THE ROOTBALLS OF VARIOUS TREE CALIPERS OR HEIGHTS. IN MANY CASES, SUCH APPROACHES RESULT IN ROOTBALLS THAT ARE EITHER TOO LARGE OR TOO SMALL FOR A GIVEN TREE. THE FOLLOWING TABLE LIST MINIMUM ROOTBALL DIAMETERS BASED ON REAL-WORLD EXPERIENCE OF TREE RELOCATION SPECIALISTS IN SOUTH FLORIDA.

CALIPER (inches)	MIN. ROOTBALL DIA. (feet)	CALIPER (inches)	MIN. ROOTBALL DIA. (feet)
1-4	3	12-14	8
4-5	4	15-17	10
6-7	5	19-24	12-15
8-9	6	25-30	15-25
10-11	7	30+	as needed

1. WHENEVER POSSIBLE, ROOTBALLS MUST BE CIRCULAR IN SHAPE WITH AN EQUAL DISTANCE FROM THE TRUNK TO THE EDGE OF ROOTBALL ALL AROUND.
2. MINIMUM ROOTBALL DEPTH MUST BE 24"-36" FOR ALL TREES TO BE RELOCATED. WITH THE ACTUAL DEPTH TO BE DETERMINED ONLY AFTER A THOROUGH EXAMINATION OF ALL ROOTS DURING THE INITIAL ROOT INSPECTION AND BASED ON THE ABSENCE OF MAJOR ROOTS AT THE BOTTOM OF THE ROOTBALL. ROOTBALLS DEEPER THAN 36" MAY BE REQUIRED FOR LARGE SPECIMEN TREES, DEPENDING ON THE RELATIVE LOCATIONS AND DEPTHS OF THE MAJOR ROOTS AS OBSERVED DURING THE INITIAL ROOT INSPECTION.
3. AS A GENERAL RULE, MINIMUM ROOT PRUNE TIME FOR TREES WITH A DBH OF LESS THAN 10" IS 12 WEEKS. THE FIRST ROOT PRUNE MUST BE ON TWO OPPOSING SIDES OF THE ROOTBALL, WITH THE SECOND ROOT PRUNE ON ONE OF THE OTHER TWO SIDES DONE A MINIMUM OF 6 WEEKS LATER, AND A THIRD ROOT PRUNE ON THE LAST SIDE DONE A MINIMUM OF 3 WEEKS AFTER THAT. THE SECOND AND THIRD ROOT PRUNES MAY ONLY BE DONE WHEN HEALTHY NEW ROOT GROWTH FROM EARLIER ROOT PRUNES IS EVIDENT (SEE SECTION 2.14 ABOVE FOR SPECIFICATIONS ON PHOTOGRAPHICALLY DOCUMENTING NEW ROOT GROWTH DURING THE ROOT PRUNE PROCESS, MORE TIME MAY BE NEEDED DURING THE COOLER MONTHS OF THE YEAR.
4. AS A GENERAL RULE, MINIMUM ROOT PRUNE TIME FOR TREES WITH A DBH OF 10" OR GREATER IS 24 WEEKS. THE FIRST ROOT PRUNE MUST BE ON TWO OPPOSING SIDES OF THE ROOTBALL, WITH THE SECOND ROOT PRUNE ON ONE OF THE OTHER TWO SIDES DONE A MINIMUM OF 12 WEEKS LATER, AND A THIRD ROOT PRUNE ON THE LAST SIDE DONE A MINIMUM OF 6 WEEKS AFTER THAT. THE SECOND AND THIRD ROOT PRUNES MAY ONLY BE DONE WHEN HEALTHY NEW ROOT GROWTH FROM EARLIER ROOT PRUNES IS EVIDENT (SEE SECTION 2.14 ABOVE FOR SPECIFICATIONS ON PHOTOGRAPHICALLY DOCUMENTING NEW ROOT GROWTH DURING THE ROOT PRUNE PROCESS, MORE TIME MAY BE NEEDED DURING THE COOLER MONTHS OF THE YEAR.
5. CERTAIN HARDWOOD TREES AND GYMNASPERMS REQUIRE LONGER ROOT PRUNING TIMES. THESE INCLUDE, BUT ARE NOT LIMITED TO, THE FOLLOWING:
 - AVOCADO (PERSEA AMERICANA)
 - BLACK OLIVE (BUCIDA BUCERAS)
 - BRIDALVEIL (CHESALPINA GRANADILLO)
 - CASSIAS (ALL SPECIES OF CASSIA)
 - LIGNUM VITAE (GUAIACUM SANCTUM & G. OFFICINALE)
 - PODOCARPUS (PODOCARPUS SP.)
 - LIVE OAK (QUERCUS VIRGINIANA)
 - MAHOGANY (SWITETIA MAHAGONI)
 - MANGO (MANGIFERA INDICA)

PALM ROOT PRUNING SPECIFICATIONS

1. THE FOLLOWING TABLE LISTS MINIMUM ROOTBALL DIAMETERS FOR VARIOUS SPECIES OF PALMS BASED ON REAL-WORLD EXPERIENCE OF RELOCATION SPECIALISTS IN SOUTH FLORIDA.

PALM SPECIES	ROOTBALL PREPARATION
SHREVEHAGE PALM	36" diameter
QUEEN PALM / COCONUT PALM	12" from trunk in all directions
ROYAL PALM / COCONUT PALM	18" from trunk in all directions
CANNY LAYER PALM	24" from trunk in all directions
SLOW-GROWING PALMS	36" from trunk in all directions

2. PALM ROOTBALL MUST BE A MINIMUM OF 24" DEEP. WHENEVER POSSIBLE, ROOTBALLS MUST BE CIRCULAR IN SHAPE WITH AN EQUAL DISTANCE FROM THE TRUNK TO THE EDGE OF THE ROOTBALL ALL AROUND.
3. AS A GENERAL RULE, MINIMUM ROOT PRUNE TIME FOR PALMS IS 6-8 WEEKS. THE FIRST ROOT PRUNE MUST BE ON TWO OPPOSING SIDES OF THE ROOTBALL, WITH THE SECOND ROOT PRUNE ON ONE OF THE OTHER TWO SIDES DONE A MINIMUM OF 3-4 WEEKS LATER, AND A THIRD ROOT PRUNE ON THE LAST SIDE DONE A MINIMUM OF 4-6 WEEKS AFTER THAT. THE SECOND AND THIRD ROOT PRUNES MAY ONLY BE DONE WHEN HEALTHY NEW ROOT GROWTH FROM EARLIER ROOT PRUNES IS EVIDENT (SEE SECTION 2.14 ABOVE FOR SPECIFICATIONS ON PHOTOGRAPHICALLY DOCUMENTING NEW ROOT GROWTH DURING THE ROOT PRUNE PROCESS, MORE TIME MAY BE NEEDED DURING THE COOLER MONTHS OF THE YEAR.
4. CERTAIN PALMS, IN PARTICULAR THOSE THAT ARE SLOW-GROWING, REQUIRE LONGER ROOT PRUNING TIME. THESE INCLUDE, BUT ARE NOT LIMITED TO, THE FOLLOWING:
 - ALL SPECIES OF ARCHONTOPHOENIX
 - ALL SPECIES OF CORYPHEA
 - AMERICAN OIL PALMS (ALL SPECIES OF ATTALEA)
 - BISMARK PALM (BISMARCKIA NOBILIS)
 - CUBAN & CARIBBEAN COPERNICIA
 - CUBAN BELLY PALM (GASTROCOCCOS CRISPA)
 - GINGERBREAD DOOM PALMS (ALL SPECIES OF HYPHENAE)
 - PALMYRA PALMS (ALL SPECIES OF BORASSUS)
 - SATAKE PALM (SATRAVENTIA LUKUENSIS)
 - SAW PALMETTO (SERENITA REPENS)
 - SILVER PALM (COCOTHRINAX ARGENTATA)
 - ZOMBIE PALM (ZOMBIA ANTILLARUM)

FOR THESE PALMS, THE MINIMUM ROOT PRUNING TIME IS 4-6 MONTHS OR GREATER. ONLY WHEN SUFFICIENT NEW ROOT GROWTH HAS TAKEN PLACE FOLLOWING AN EARLIER ROOT PRUNE CAN THE NEXT ROOT PRUNE BE DONE, AND ONLY WHEN SUFFICIENT NEW ROOT GROWTH HAS TAKEN PLACE FOLLOWING THE FINAL ROOT PRUNE MAY THE TREE BE RELOCATED (SEE SECTION 2.14 ABOVE FOR SPECIFICATIONS ON PHOTOGRAPHICALLY DOCUMENTING NEW ROOT GROWTH DURING THE ROOT PRUNE PROCESS).

TREE CANOPY PRUNING SPECIFICATIONS

1. PRIOR TO RELOCATION, THE CANOPY OF EACH TREE TO BE RELOCATED MUST BE SELECTIVELY PRUNED TO REMOVE CROSSING DEAD, DISEASED, BROKEN, AND LOW HANGING BRANCHES THAT MAY INTERFERE WITH CONSTRUCTION ACTIVITIES, OR THAT MAY INTERFERE OR RESTRICT STRAPPING OR LIFTING THE TREE DURING RELOCATION.
2. FOR TREES BEING RELOCATED ON SITE, THE CANOPY MAY BE SELECTIVELY THINNED AND REDUCED BY NO MORE THAN 1/3 OF THE OVERALL CANOPY MASS AT THE DIRECTION OF THE LANDSCAPE ARCHITECT; HOWEVER, THE BASIC SHAPE, FORM, AND CHARACTER OF THE TREES MUST BE PRESERVED.
3. FOR TREES BEING RELOCATED OFF SITE, THE CANOPY MUST BE PRUNED, AT THE DIRECTION OF THE LANDSCAPE ARCHITECT, TO FIT ON THE TRAILER FOR TRANSPORT. EVERY EFFORT MUST BE MADE TO RETAIN AS MANY BRANCHES AS POSSIBLE, TO THE WIDEST LOAD WIDTH ALLOWABLE BY THE FLORIDA DEPARTMENT OF TRANSPORTATION. CONTRACTOR MUST OBTAIN ALL NECESSARY PERMITS AND ESCORTS TO TRANSPORT WIDE LOADS, PER FLORIDA LAW.
4. ALL CANOPY PRUNING MUST BE CONDUCTED FOLLOWING ANSI A-300 TREE PRUNING STANDARDS AND BEST MANAGEMENT PRACTICES.
5. ALL DEBRIS GENERATED DURING CANOPY PRUNING MUST BE REMOVED OFF SITE AND DISPOSED.

PALM CANOPY PRUNING SPECIFICATIONS

1. IT IS WELL KNOWN THAT SOME PALMS SURVIVE RELOCATION BETTER WHEN ALL OF THE LEAVES ARE REMOVED (E.G., CABBAGE PALM, SABAL PALMETTO), AND THAT OTHER PALMS BENEFIT FROM HAVING THEIR LEAVES CUT IN HALF DURING RELOCATION (E.G., COCONUT PALM, COCOS NUCLIFERA). BOTH OF THESE HORTICULTURAL PRACTICES, WHILE TRUE, ARE ONLY APPLICABLE WHEN PALMS ARE NOT ROOT PRUNED. LEAVES DO NOT NEED TO BE CUT IN HALF OR REMOVED FROM PALMS THAT ARE ADEQUATELY ROOT PRUNED. ON OCCASION WHEN SUFFICIENT ROOT PRUNING TIME IS NOT AVAILABLE, PALMS TO BE RELOCATED MAY HAVE THEIR LEAVES CUT IN HALF OR REMOVED ENTIRELY AT THE DIRECTION OF THE LANDSCAPE ARCHITECT.
2. PALM LEAVES MUST BE TIED UP WITH 2-PLY BIODEGRADABLE TWINE PRIOR TO RELOCATION TO PREVENT MECHANICAL DAMAGE DURING THE RELOCATION PROCESS.
3. PALM TRUNKS SHALL ONLY BE "CLEANED UP" ACCORDING TO THE LANDSCAPE ARCHITECT'S SPECIFICATIONS SPECIFIC TO EACH PALM.



1447 cypress drive, 2
jupiter, fl 33469
561.402.9414

www.nielsenlandarch.com

LOT 10 GARDEN
1180 BAY DRIVE | MIAMI BEACH, FLORIDA 33141

SEAL OF TYLER NIELSEN - LAB07001

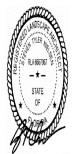

07.02.2025

TREE DISPOSITION NOTES

DATE	ISSUE
05.07.2023	55% CD
06.21.2023	55% CD
07.09.2023	75% CD
07.25.2024	75% CD
02.28.2024	100% CD
01.13.2025	COORDINATION
07.09.2025	DPS SUBMITTAL

L100

COPYRIGHT NIELSEN LANDSCAPE ARCHITECTS, LLC

TREES PROTECTION NOTES

- CONTRACTOR TO PROTECT ALL EXISTING TREES PRIOR TO THE DEMOLITION OF THE EXISTING STRUCTURE.
- UPON COMPLETION OF SITE DEMOLITION, CONTRACTOR TO RELOCATE ALL SPECIFIED TREES AND PALMS FOR RELOCATION. CONTRACTOR TO REINSTALL TREE PROTECTION FENCE AROUND RELOCATED AND EXISTING TREES.
- FENCING AT A MINIMUM FOUR (4) FEET HEIGHT INSTALLED NO CLOSER TO THE TREE TRUNK THAN ITS DRIPLINE. THIS FENCE SHALL BE MAINTAINED IN WORKING ORDER DURING ALL PHASES OF CONSTRUCTION. MAINTAIN TREE PROTECTION ZONES FREE OF WEEDS AND TRASH.
- THE PROJECT LIMIT OF CONSTRUCTION AND ALL EXISTING VEGETATION TO REMAIN IS TO BE CLEARLY DENIED BY STURDY, WEATHERPROOF FENCING AT A MINIMUM OF FOUR (4) FEET HIGH.
- STURDY TEMPORARY BARRIERS SHALL BE INSTALLED AROUND ALL TREE PROTECTION ZONES. BARRIERS SHALL BE A MINIMUM OF FOUR FEET HIGH, AND SHALL BE CONSTRUCTED OF CONTINUOUS CHAIN LINK FENCE WITH METAL POSTS AT EIGHT-FOOT SPACING, OR OF TWO-BY-FOUR INCH POSTS WITH THREE EQUALLY SPACED TWO-BY-FOUR RAILS. POSTS MAY BE SHIFTED TO AVOID ROOTS.

MAINTENANCE SPECIFICATIONS

- ALL RELOCATED TREES AND PALMS MUST BE MAINTAINED FOR ONE YEAR FROM THE DATE OF RELOCATION TO THEIR FINAL LOCATIONS.
- CONTRACTOR MUST MAINTAIN ALL RELOCATED TREES AND PALMS FOR ONE FULL YEAR FROM THE DATE OF RELOCATION TO THE FINAL LOCATION.
- WHENEVER POSSIBLE, EACH TREE AND PALM MUST BE WATERED BY A PERMANENT AUTOMATIC IRRIGATION SYSTEM FOLLOWING RELOCATION. EACH WATERING MUST THOROUGHLY SATURATE THE ROOTBALL TO ITS FULL DEPTH; THIS WILL REQUIRE 25-30 GALLONS OF WATER FOR SMALL TREES AND PALMS DEPENDING ON ROOTBALL SIZE. WHILE LARGE TREES WILL REQUIRE A MINIMUM OF 10 GALLONS PER FOOT OF ROOTBALL DIAMETER (I.E., A 10" DIAMETER ROOTBALL WILL REQUIRE A MINIMUM OF 100 GALLONS PER WATERING EVENT), WATERING FREQUENCY MUST BE EVERY DAY FOR THE FIRST TWO WEEKS, EVERY OTHER DAY FOR THE NEXT THREE WEEKS, AND EVERY THIRD DAY FOR THE NEXT 6-8 WEEKS.
- WHEN AN AUTOMATIC IRRIGATION SYSTEM IS NOT POSSIBLE, CONTRACTOR IS RESPONSIBLE FOR HAND WATERING RELOCATED TREES AND PALMS THROUGHOUT THE MAINTENANCE PERIOD AND UNTIL FINAL ACCEPTANCE BY THE LANDSCAPE ARCHITECT AND/OR CLIENT.
- IMMEDIATELY AFTER RELOCATION TO THE FINAL LOCATION, A HIGH-PHOSPHORUS ROOT STIMULANT MUST BE APPLIED TO THE SURFACE OF THE ROOTBALL AT THE RECOMMENDED LABEL RATE AND WATERED IN WITH A DRENCH CONSISTING OF A SYSTEMIC INSECTICIDE AND A CONTACT ROOT ROT FUNGICIDE, FOLLOWING LABEL INSTRUCTIONS, AS INITIAL PREVENTATIVE MAINTENANCE.
- EVERY THREE MONTHS THEREAFTER, A HIGH-PHOSPHORUS ROOT STIMULANT MUST BE APPLIED TO THE SURFACE OF THE ROOTBALL AT THE RECOMMENDED LABEL RATE AND WATERED IN WITH A DRENCH CONSISTING OF A SYSTEMIC INSECTICIDE AND A BROAD-SPECTRUM SYSTEMIC FUNGICIDE, FOLLOWING LABEL INSTRUCTIONS, AS CONTINUING PREVENTATIVE MAINTENANCE.
- IRRIGATION AND BRACING MUST BE CHECKED AND EACH TREE OR PALM THOROUGHLY INSPECTED FOR SIGNS OF STRESS, DISEASE, OR PEST PROBLEMS ON A MONTHLY BASIS.
- IMMEDIATELY AFTER RELOCATION TO THE FINAL LOCATION AND EVERY THREE MONTHS THEREAFTER, A HIGH-QUALITY, SLOW-RELEASE 15-2-15 GRANULAR FERTILIZER MUST BE APPLIED, AT THE RECOMMENDED LABEL RATE, SPREAD EVENLY ACROSS THE SURFACE OF THE ROOTBALL.
- IMMEDIATELY AFTER RELOCATION TO THE FINAL LOCATION AND EVERY THREE MONTHS THEREAFTER, A HIGH-QUALITY, SLOW-RELEASE 15-2-15 GRANULAR FERTILIZER MUST BE APPLIED, AT THE RECOMMENDED LABEL RATE, SPREAD EVENLY ACROSS THE SURFACE OF THE ROOTBALL.
- FOLIAR FEED FOUR TIMES PER YEAR.
- STRING MUST BE REMOVED FROM THE TIED UP LEAVES IMMEDIATELY AFTER RELOCATION TO THE FINAL LOCATION IF THE PALM WAS ROOT PRUNED OR WITHIN 30-45 DAYS AFTER RELOCATION ON THE OCCASION THE LANDSCAPE ARCHITECT APPROVED RELOCATION WITHOUT ROOT PRUNING DUE TO TIME CONSTRAINTS.
- IMMEDIATELY AFTER RELOCATION TO THE FINAL LOCATION AND EVERY THREE MONTHS THEREAFTER, A HIGH-QUALITY, SLOW-RELEASE 8-4-12 GRANULAR PALM FERTILIZER WITH MINORS MUST BE APPLIED, AT THE RECOMMENDED LABEL RATE, SPREAD EVENLY ACROSS THE SURFACE OF THE ROOTBALL.
- FOLIAR FEED PALMS SIX TIMES PER YEAR.

RELOCATION SPECIFICATIONS

- LANDSCAPE CONTRACTOR TO FLAG ALL PROPOSED PLANT LOCATIONS FOR LANDSCAPE ARCHITECT'S APPROVAL PRIOR TO INSTALLATION. NOTIFY LANDSCAPE ARCHITECT A MINIMUM OF 15 DAYS PRIOR TO REVIEW.
- ALL TREES AND PALMS TO BE RELOCATED MUST BE WATERED DAILY FOR AT LEAST 5 DAYS PRIOR TO ANY RELOCATION TO ENSURE THAT THEY ARE FULLY HYDRATED. EACH WATERING MUST THOROUGHLY SATURATE THE ROOTBALL TO ITS FULL DEPTH.
- ALL ROOTBALLS MUST BE WRAPPED IN BURLAP AND THE TIGHTLY WIRE-WRAPPED (USING REDLINE HORSE WIRE OR EQUIVALENT) TO KEEP THE ENTIRE ROOTBALL INTACT DURING RELOCATION. TREES AND PALMS GROWING IN LIMESTONE MUST BE DUG AND RELOCATED WITH THE ROOT ATTACHED TO A SECTION OF ROCK AS PART OF THE ROOTBALL, SUCH THAT THE ROOTS REMAIN INTACT. ROOTBALLS COMING FROM SAND OR SANDY SOIL MAY ALSO NEED TO BE BOXED PRIOR TO RELOCATION, AT THE DISCRETION OF THE LANDSCAPE ARCHITECT.
- TREES AND PALMS BEING RELOCATED OFFSITE MUST HAVE THEIR ENTIRE ROOTBALLS THOROUGHLY AND TIGHTLY WRAPPED WITH PLASTIC SHRINK WRAP ON THE OUTSIDE OF THE WIRE WRAP, AND THE ENTIRE TREE OR PALM (INCLUDING CANOPY, TRUNK, AND ROOTBALL) MUST BE COVERED WITH A BREATHABLE TARP (E.G., SHADE CLOTH) DURING TRANSPORT.
- NEW PLANTING PITS FOR RELOCATED TREES AND PALMS MUST BE PREPARED PRIOR TO LIFTING THE PALM OR TREE FROM ITS CURRENT LOCATION AND MUST BE AT LEAST 3-4 FEET WIDER THAN THE ROOTBALL AND THE SAME DEPTH AS THE ROOTBALL, SUCH THAT THE FINAL ELEVATION OF THE TOP OF THE ROOTBALL IS AT OR SLIGHTLY ABOVE NO MORE THAN 2" HIGHER FINAL GRADE.
- TREES AND PALMS TO BE RELOCATED MUST BE LIFTED BY THE ROOTBALL ONLY, USING APPROPRIATELY SIZED (LENGTH AND STRENGTH) LIFTING STRAPS OR CHAINS. DURING LIFTING, THE TREE OR PALM MUST BE BALANCED IN A MORE OR LESS UPRIGHT POSITION, WITH THE STRAP/THE TRUNK USED ONLY FOR BALANCING AND MANEUVERING THE TREE OR PALM INTO A POSITION. NO CHAINS MAY BE USED AROUND OR AGAINST THE TRUNK AT ANY TIME. AT NO TIME SHALL 100% OF THE WEIGHT OF THE TREE OR PALM BE ON THE STRAP ATTACHED TO THE TRUNK. TRUNKS MUST BE HEAVILY PADDED WITH 30-40 LAYERS (DEPENDING ON SIZE AND WEIGHT) OF BURLAP BENEATH THE BALANCING STRAP.
- TREES AND PALMS MUST BE LIFTED WITH A CRANE OR BACKHOE APPROPRIATELY SIZED FOR THE SIZE AND WEIGHT OF THE TREE OR PALM AND LIFTED OR CARRIED DIRECTLY TO THE FINAL INSTALL LOCATION OR TRANSPORT TRAILER.
- ONCE LIFTING BEGINS, ANY UNLIFTED ROOTS UNDER OR AROUND THE ROOTBALL THAT MAY YET REMAIN MUST BE IMMEDIATELY SEVERED WITH HAND PRUNING TOOLS TO MINIMIZE TEARING AND ROOT DAMAGE.
- AGRIFORM PLANTING TABLETS (OR APPROVED EQUIVALENT) MUST BE EVENLY DISTRIBUTED AROUND THE PERIMETER OF THE PLANTING PIT AT THE RATE OF 2 TABLETS PER 1" TRUNK CALIPER PRIOR TO BACKFILLING.
- MYCORRHIZA (ROOTS) (TRANSPLANT OR EQUIVALENT) MUST BE INCORPORATED INTO THE BACKFILL SOIL PRIOR TO BACKFILLING.
- RELOCATED TREES AND PALMS MUST BE CENTERED IN THE PLANTING PIT, AND THE PIT BACKFILLED USING A 1:1 MIXTURE OF EXISTING SOIL AND 80:20 (DOT SAND/MULCH) SOIL MIX THOROUGHLY BLENDED TOGETHER. DO NOT USE MUDDY SOIL AS BACKFILL.
- SMALL TREES AND PALMS MUST BE FIRMLY BRACED USING A MINIMUM OF FOUR 4" X 4" WOODEN BRACES ATTACHED TO 2" X 4" WOODEN BATTENS HELD IN PLACE WITH TWO STEEL BANDS. LARGER TREES MAY REQUIRE 6" X 6" WOODEN POSTS OR EVEN TELEPHONE POLES TO PROVIDE SUFFICIENT BRACING STRENGTH TO PREVENT TOPPLING DURING WIND EVENTS. A SUFFICIENT NUMBER OF BATTENS MUST BE STRATEGICALLY PLACED AROUND THE TRUNK, SUCH THAT THE STEEL BANDS NEVER CONTACT THE TRUNK. NO BURLAP IS TO REMAIN UNDER THE WOODEN BATTENS ON TREES DURING BRACING, BUT SEVERAL LAYERS OF BURLAP SHOULD BE LEFT UNDER THE WOODEN BATTENS WHEN BRACING PALMS. NAILS SHALL NEVER BE DRIVEN DIRECTLY INTO THE TRUNK DURING BRACING. BRACING MUST REMAIN IN PLACE FOR A MINIMUM OF ONE YEAR.
- A TREE RING WITH A MINIMUM HEIGHT OF 6" MUST BE CONSTRUCTED 6-12" OUTSIDE THE OUTERMOST EDGE OF THE ROOTBALL AND AROUND THE ENTIRE PERIMETER OF THE ROOTBALL TO DIRECT IRRIGATION WATER AND ANY SUPPLEMENTS THAT ARE ADDED DOWN INTO THE ROOTBALL DURING ROOT REGENERATION.
- ONCE THE TREE RING IS CONSTRUCTED, A HIGH-PHOSPHORUS ROOT STIMULANT MUST BE LIBERALLY APPLIED TO THE SURFACE AND THOROUGHLY WATERED IN.
- ROOTBALLS MUST BE THOROUGHLY WATERED IN USING A HOSE AND JOHNSON BAR INSERTED TO THE VERY BOTTOM OF THE ROOTBALL AND SWUNG BACK AND FORTH TO PREVENT FORMATION OF AIR POCKETS. THE JOHNSON BAR TECHNIQUE MUST BE REPEATED AT LEAST ONCE MORE WITHIN 6" OF THE TRUNK. MULCH MUST NOT BE APPLIED OR ALLOWED TO ACCUMULATE DIRECTLY AGAINST THE TRUNK.
- ORGANIC MULCH (MELALEUCA IS PREFERRED) MUST BE APPLIED WITHIN 48 HOURS OF RELOCATION AT A DEPTH OF 3-4" OVER THE ENTIRE TOP OF THE ROOTBALL FROM THE TREE RING TO WITHIN 6" OF THE TRUNK. MULCH MUST NOT BE APPLIED OR ALLOWED TO ACCUMULATE DIRECTLY AGAINST THE TRUNK.
- PITS FROM WHICH THE RELOCATED TREES AND PALMS WERE REMOVED MUST BE CLEANED OFF ALL RESIDUAL ROOTS, STUMPS, AND PORTIONS THEREOF AND BACKFILLED WITH CLEAN FILL FLUSH WITH THE SURROUNDING GRADE.
- RESTORE THE SURFACE WITH MATERIAL TO MATCH ADJACENT AREAS. MATERIAL TO BE APPROVED BY LANDSCAPE ARCHITECT. CONTRACTOR TO PROVIDE A MINIMUM OF ONE YEAR WARRANTY ON SETTLING AND PLANT MATERIAL FROM THE SUBSTANTIAL COMPLETION.
- MULTI-TRUNK TREES AND PALMS MUST BE RELOCATED AS ONE UNIT WITH A SINGLE ROOTBALL.
- PLANTING PITS FOR EDIBLE DATE PALMS (PHOENIX DACTYLIFERA) MUST BE BACKFILLED WITH PURE DOT SILICA SAND.

WARRANTY NOTES

- ALL RELOCATED TREES AND PALMS MUST BE GUARANTEED FOR ONE YEAR FROM THE DATE OF RELOCATION TO THEIR FINAL LOCATIONS.
- IF A TREE OR PALM DIES WITHIN THE 1-YEAR WARRANTY PERIOD, IT MUST BE REMOVED AND REPLACED AT CONTRACTOR'S EXPENSE.
- IF A TREE OR PALM PERFORMS POORLY WITHIN THE 1-YEAR WARRANTY PERIOD, IT MUST BE REMOVED AND REPLACED AT CONTRACTOR'S EXPENSE. THE DECISION TO REPLACE BASED ON POOR HEALTH IS AT THE DISCRETION OF THE LANDSCAPE ARCHITECT.
- IF A TREE OR PALM SETTLES TO AN UNHEALTHY DEPTH WITHIN THE 1-YEAR WARRANTY PERIOD, AS DETERMINED BY THE LANDSCAPE ARCHITECT, IT MUST BE RAISED TO THE CORRECT GRADE AT CONTRACTOR'S EXPENSE.

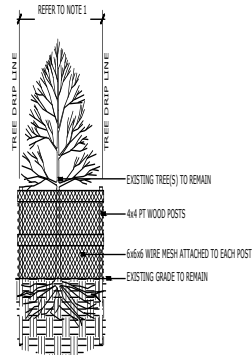

- NOTE:
- DUE TO SITE CONSTRAINTS TREE PROTECTION FENCE MAY BE CONTINUOUS TO PROTECT MULTIPLE TREES. TREE PROTECTION FENCE TO BE INSTALLED AT EDGE OF EXISTING HARDSCAPE WHERE SPACE ALLOWS TREE PROTECTION FENCE TO ALIGN WITH DRIPLINE OF TREE / PALM.
 - MAINTAIN FENCE THROUGHOUT CONSTRUCTION.
 - REFER TO LOCAL, STATE AND FEDERAL JURISDICTIONS AND GOVERNING BODIES/AGENCIES FOR ADDITIONAL REQUIREMENTS.

1 TREE PROTECTION FENCE

Scale: 1/4" = 1'-0"



www.nielsenlandarch.com

LOT 10 GARDEN

11500 BAY DRIVE | MIAMI BEACH, FLORIDA 33141

SEAL OF TYLER NIELSEN - LAB0701

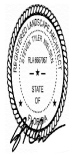

07.02.2025

TREE DISPOSITION NOTES

DATE	ISSUE
05.17.2023	25% CD
06.21.2023	50% CD
07.19.2023	75% CD
07.25.2024	75% CD
02.28.2024	100% CD
01.13.2025	COORDINATION
07.02.2025	DRS SUBMITTAL

L101

COPYRIGHT NIELSEN LANDSCAPE ARCHITECTS, LLC

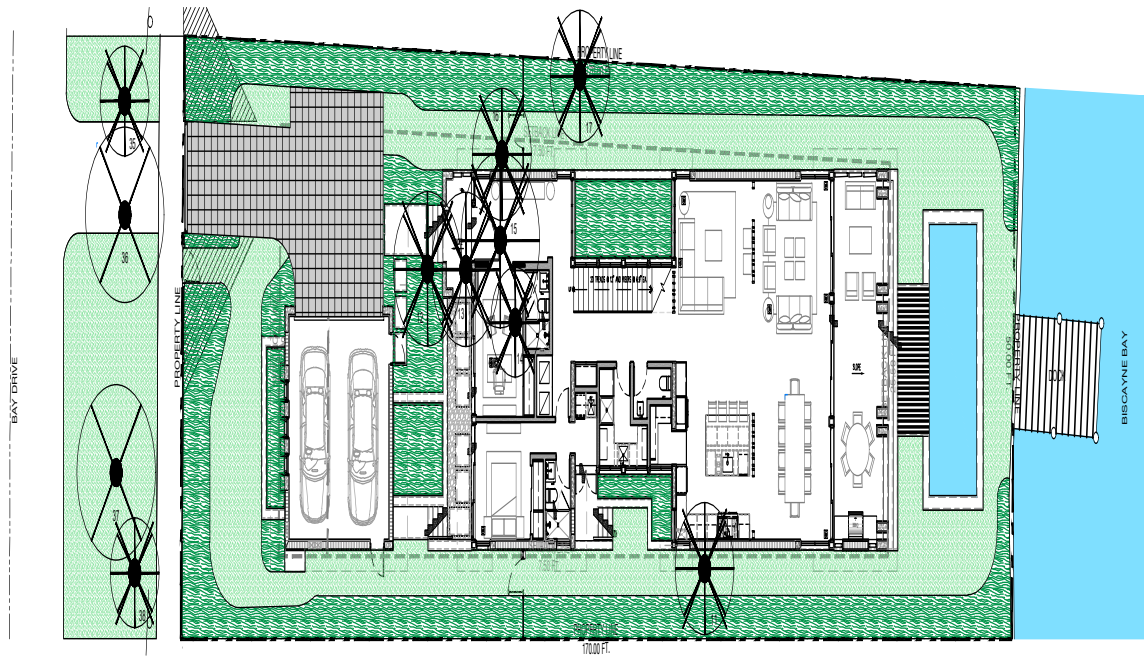

NIELSEN
Landscape architects
1447 cypress drive, 2
jupiter, FL 33469
561.402.9414
www.nielsenlandarch.com

REFERENCE IMAGERY



MITIGATION NOTES

THE PROPOSED LANDSCAPE PLAN MUST MITIGATE THE REMOVAL OF 24 DBH. INCHES OF TREES REMOVED AND 9 PALMS WITH A TOTAL OF:
 (8) TREES 2 IN. DBH. x 4 FT. SPR. x 12 FT. HT.
 OR
 (4) TREES 4 IN. DBH x 8 FT. SPR. x 16 FT. HT.
 NO MITIGATION REQUIRED FOR REMOVAL OF INVASIVE TREES.

THE PLANTING PLAN PROPOSES TO MITIGATE WITH THE FOLLOWING STRATEGY:
 (4) COCCOLOBA DIVERSIFOLIA - FG. 4 IN. DBH / 16 FT. HT. / 8 FT. SPR.

TOTAL REMOVALS

- 2 TREES REMOVED WITH A TOTAL OF 24 DBH. INCHES REMOVED
 - 9 PALMS REMOVED
 - 0 INVASIVE TREES REMOVED
- REFER TO SHEET L700 & L701 FOR MITIGATION TREES & PALMS SPECIES, SPECIFICATIONS, AND LAYOUT.

LOT 10 GARDEN
 1100 BAY DRIVE | MIAMI BEACH, FLORIDA 33141

SEAL (S) TYLER NIELSEN - LABR1701



TREE DISPOSITION SCHEDULE

#	BOTANICAL NAME	COMMON NAME	DBH	HT.	SPREAD	ACTION	NOTES	CONDITION
11	VIETCHA MERRILLIS	CHRISTMAS PALM	6.75"	20'	12'	REMOVE	PLANT MATERIAL CONFLICTS WITH CONSTRUCTION ENVELOPE	FAIR
12	PTICHOSPERMA ELEGANS	ALEXANDER PALM	3.50"	20'	15'	REMOVE	PLANT MATERIAL CONFLICTS WITH CONSTRUCTION ENVELOPE	FAIR
13	PTICHOSPERMA ELEGANS	ALEXANDER PALM	3.75"	25'	15'	REMOVE	PLANT MATERIAL CONFLICTS WITH CONSTRUCTION ENVELOPE	FAIR
14	DYPSIS LUTESCENS	ARECA PALM	3.25"	14'	10'	REMOVE	PLANT MATERIAL CONFLICTS WITH CONSTRUCTION ENVELOPE	POOR
15	VIETCHA MERRILLIS	CHRISTMAS PALM	7"	25'	20'	REMOVE	PLANT MATERIAL CONFLICTS WITH CONSTRUCTION ENVELOPE	FAIR
16	DYPSIS LUTESCENS	ARECA PALM	3.5"	14'	12'	REMOVE	PLANT MATERIAL CONFLICTS WITH CONSTRUCTION ENVELOPE	POOR
17	PTICHOSPERMA ELEGANS	ALEXANDER PALM	3.75"	16'	12'	REMOVE	PLANT MATERIAL CONFLICTS WITH CONSTRUCTION ENVELOPE	FAIR
35	VIETCHA MERRILLIS	CHRISTMAS PALM	5"	14'	16'	REMOVE	PLANT MATERIAL CONFLICTS WITH CONSTRUCTION ENVELOPE	FAIR
36	PONGAMIA PINNATA	PONGAM TREE	14"	25'	30'	REMOVE	PLANT MATERIAL CONFLICTS WITH CONSTRUCTION ENVELOPE	FAIR
37	PONGAMIA PINNATA	PONGAM TREE	10"	20'	25'	REMOVE	PLANT MATERIAL CONFLICTS WITH CONSTRUCTION ENVELOPE	FAIR
38	VIETCHA MERRILLIS	CHRISTMAS PALM	4"	16'	12'	REMOVE	PLANT MATERIAL CONFLICTS WITH CONSTRUCTION ENVELOPE	FAIR

TREE DISPOSITION LEGEND

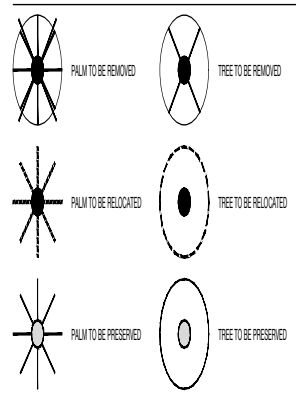

TREE DISPOSITION PLAN

DATE	ISSUE
05.07.2023	50% CD
06.21.2023	50% CD
07.19.2023	75% CD
07.25.2024	75% CD
02.28.2024	100% CD
01.13.2025	COORDINATION
07.08.2025	DRS SUBMITTAL

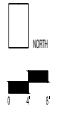

L102

© COPYRIGHT NIELSEN LANDSCAPE ARCHITECTS, LLC

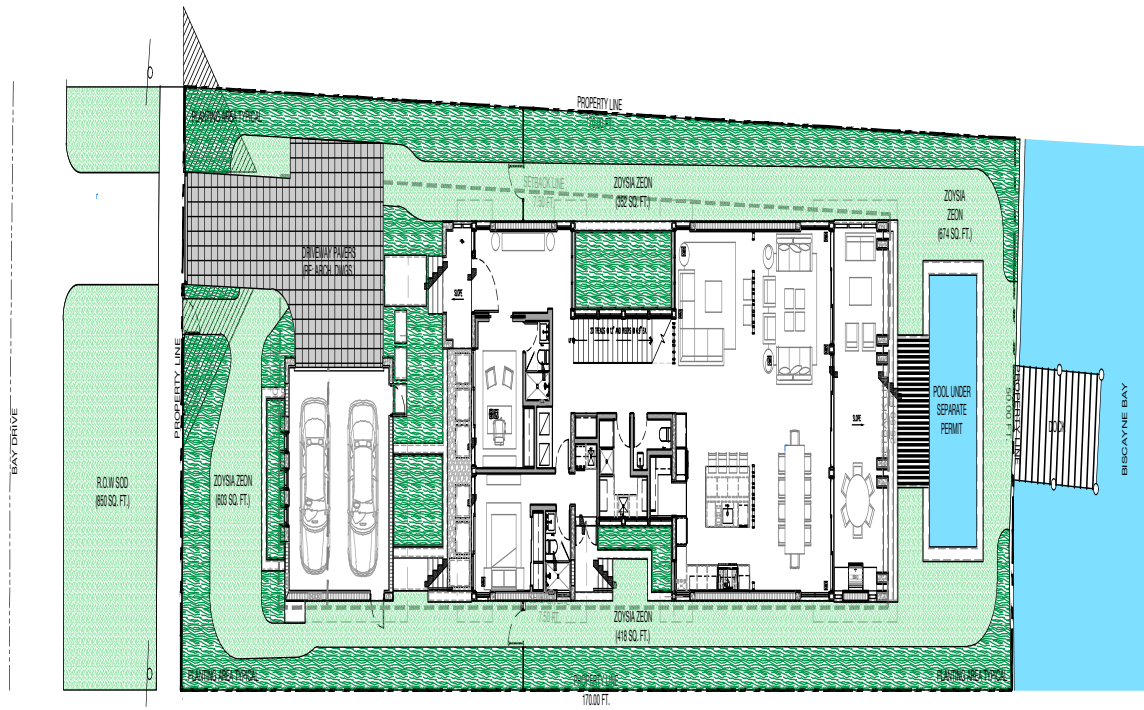

NIELSEN
Landscape architects

1447 cypress drive, 2
jupiter, FL 33469
561.402.9414

www.nielsenlandarch.com

LOT 10 GARDEN
11300 BAY DRIVE | MIAMI BEACH, FLORIDA 33141

MATERIALS NOTES

1. CONTRACTOR TO VERIFY ALL QUANTITIES. IN CASE OF ANY DISCREPANCIES, GRAPHICALLY SHOWN MATERIAL QUANTITIES SHALL TAKE PRECEDENCE.
2. ALL CONSTRUCTION AND MATERIALS NOT SPECIFICALLY ADDRESSED IN THE CONTRACT DOCUMENTS OR SPECIFICATIONS SHALL BE IN ACCORDANCE WITH LOCAL, STATE AND FEDERAL JURISDICTIONS AND GOVERNING BODIES/AGENCIES STANDARDS.
3. THE CONTRACTOR SHALL PROVIDE A FULL-SCALE MOCKUP AND RECEIVE APPROVAL FROM THE LANDSCAPE ARCHITECT FOR ALL SYSTEMS BEFORE BEGINNING CONSTRUCTION OF PAVEMENT.
4. EXPANSION JOINTS SHALL BE PROVIDED WHERE FLATWORK MEETS VERTICAL STRUCTURES, SUCH AS WALLS, CURBS, STEPS, AND OTHER HARDSCAPE ELEMENTS. EXPANSION JOINTS SHALL ALSO BE PROVIDED AT MATERIAL CHANGES. EXPANSION JOINT MATERIALS/METHODS SHALL BE SUBMITTED TO THE LANDSCAPE ARCHITECT FOR REVIEW AND APPROVAL PRIOR TO INSTALLATION.
5. CONTROL JOINTS SHOULD BE SPACED NO GREATER THAN TEN (10) LINEAR FEET MAXIMUM, UNLESS OTHERWISE SPECIFIED. EXPANSION JOINTS SHOULD BE SPACED NO GREATER THAN FORTY (40) LINEAR FEET MAXIMUM, UNLESS OTHERWISE SPECIFIED. CONTRACTOR SHALL ADVISE ON OTHER JOINTS AS NEEDED TO MINIMIZE CRACKING. THIS INFORMATION SHALL BE SUBMITTED TO THE LANDSCAPE ARCHITECT FOR REVIEW AND APPROVAL PRIOR TO INSTALLATION.
6. CONTROL JOINTS SHALL BE PROVIDED AS SPECIFIED IN THE CONTRACT DOCUMENTS. CONTROL JOINT MATERIALS, METHODS AND RECOMMENDATIONS ON ADDITIONAL CONTROL JOINTS TO MINIMIZE CRACKING SHALL BE SUBMITTED TO THE LANDSCAPE ARCHITECT FOR REVIEW AND APPROVAL.
7. ALL STEPS SHALL HAVE TWELVE (12) INCH TREADS AND SIX (6) INCH RISERS, UNLESS OTHERWISE SPECIFIED.
8. HOLD TOP OF WALLS AND FENCES LEVEL, UNLESS OTHERWISE SPECIFIED.
9. CONTRACTOR SHALL NOT INSTALL WORK LOCATED ON TOP OF ARCHITECTURAL STRUCTURES WITHOUT FIRST REVIEWING ARCHITECTURAL DRAWINGS.
10. SAMPLES OF SPECIFIED MATERIALS SHALL BE SUBMITTED TO THE LANDSCAPE ARCHITECT FOR REVIEW AND APPROVAL PRIOR TO ORDERING FOR JOB.

MATERIALS LEGEND

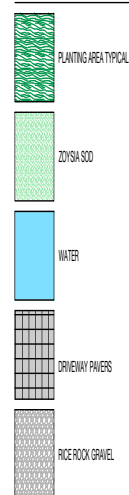

SEAL (S TYLER NIELSEN - LAB67067)

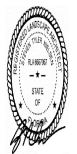

MATERIALS PLAN

DATE	ISSUE
05.17.2023	50% CD
06.21.2023	50% CD
07.19.2023	75% CD
07.25.2024	75% CD
02.28.2024	100% CD
01.13.2025	COORDINATION
07.02.2025	DRS SUBMITTAL



1" = 4'

L300

© COPYRIGHT NIELSEN LANDSCAPE ARCHITECTS, LLC

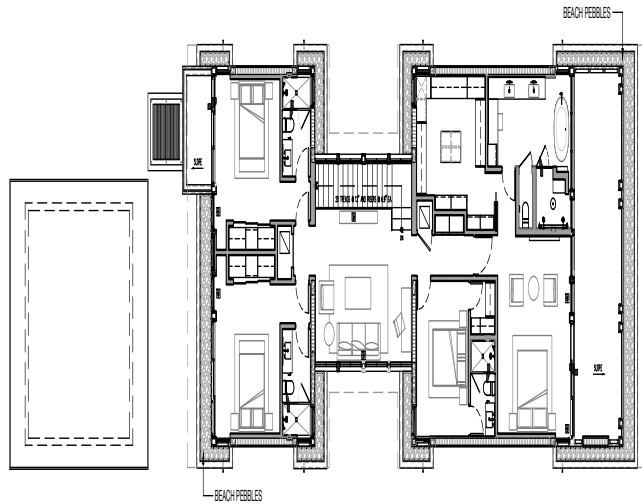

* NO PLANTING ON SECOND LEVEL ARCHITECTURAL EYEBROWS



NIELSEN
landscape architects

1447 cypress drive, 2
jupiter, fl 33469
561.402.9414

www.nielsenlandarch.com

LOT 10 GARDEN
1150 BAY DRIVE | MIAMI BEACH, FLORIDA 33141

MATERIALS NOTES

- CONTRACTOR TO VERIFY ALL QUANTITIES. IN CASE OF ANY DISCREPANCIES, GRAPHICALLY SHOWN MATERIAL QUANTITIES SHALL TAKE PRECEDENCE.
- ALL CONSTRUCTION AND MATERIALS NOT SPECIFICALLY ADDRESSED IN THE CONTRACT DOCUMENTS OR SPECIFICATIONS SHALL BE IN ACCORDANCE WITH LOCAL, STATE AND FEDERAL JURISDICTIONS AND GOVERNING BODIES/AGENCIES STANDARDS.
- THE CONTRACTOR SHALL PROVIDE A FULL-SCALE MOCKUP AND RECEIVE APPROVAL FROM THE LANDSCAPE ARCHITECT FOR ALL SYSTEMS BEFORE BEGINNING CONSTRUCTION OF PAVEMENT.
- EXPANSION JOINTS SHALL BE PROVIDED WHERE FLATWORK MEETS VERTICAL STRUCTURES, SUCH AS WALLS, CURBS, STEPS, AND OTHER HARDSCAPE ELEMENTS. EXPANSION JOINTS SHALL ALSO BE PROVIDED AT MATERIAL CHANGES. EXPANSION JOINT MATERIALS/METHODS SHALL BE SUBMITTED TO THE LANDSCAPE ARCHITECT FOR REVIEW AND APPROVAL PRIOR TO INSTALLATION.
- CONTROL JOINTS SHOULD BE SPACED NO GREATER THAN TEN (10) LINEAR FEET MAXIMUM, UNLESS OTHERWISE SPECIFIED. EXPANSION JOINTS SHOULD BE SPACED NO GREATER THAN FORTY (40) LINEAR FEET MAXIMUM, UNLESS OTHERWISE SPECIFIED. CONTRACTOR SHALL ADVISE ON OTHER JOINTS AS NEEDED TO MINIMIZE CRACKING. THIS INFORMATION SHALL BE SUBMITTED TO THE LANDSCAPE ARCHITECT FOR REVIEW AND APPROVAL PRIOR TO INSTALLATION.
- CONTROL JOINTS SHALL BE PROVIDED AS SPECIFIED IN THE CONTRACT DOCUMENTS. CONTROL JOINT MATERIALS, METHODS AND RECOMMENDATIONS ON ADDITIONAL CONTROL JOINTS TO MINIMIZE CRACKING SHALL BE SUBMITTED TO THE LANDSCAPE ARCHITECT FOR REVIEW AND APPROVAL.
- ALL STEPS SHALL HAVE TWELVE (12) INCH TREADS AND SIX (6) INCH RISERS, UNLESS OTHERWISE SPECIFIED.
- HOLD TOP OF WALLS AND FENCES LEVEL, UNLESS OTHERWISE SPECIFIED.
- CONTRACTOR SHALL NOT INSTALL WORK LOCATED ON TOP OF ARCHITECTURAL STRUCTURES WITHOUT FIRST REVIEWING ARCHITECTURAL DRAWINGS.
- SAMPLES OF SPECIFIED MATERIALS SHALL BE SUBMITTED TO THE LANDSCAPE ARCHITECT FOR REVIEW AND APPROVAL PRIOR TO ORDERING FOR JOB.

MATERIALS LEGEND



SEAL (S) TYLER NIELSEN - LAB07001

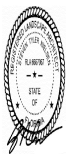

MATERIALS PLAN - SECOND LEVEL

DATE	ISSUE
05.17.2023	50% CD
06.21.2023	50% CD
07.19.2023	75% CD
07.25.2024	75% CD
02.28.2024	100% CD
01.13.2025	COORDINATION
07.02.2025	DRS SUBMITTAL



L301

© COPYRIGHT NIELSEN LANDSCAPE ARCHITECTS, LLC

PLANTING NOTES

- PLANT MATERIAL IS TO BE HEALTHY SPECIMENS FREE FROM DISEASE OR DAMAGE, AND IS TO BE MAINTAINED IN EXCELLENT CONDITION WHILE ON THE JOBSITE. LANDSCAPE ARCHITECT SHALL INSPECT PLANT MATERIAL UPON ARRIVAL TO JOBSITE AND WILL REJECT PLANT MATERIAL THAT DOES NOT MEET THE STANDARDS DESCRIBED WITHIN THE CONTRACT DOCUMENTS.
- PROVIDE MATCHING SIZES AND FORMS FOR EACH PLANT OF THE SAME SPECIES UNLESS OTHERWISE INDICATED.
- CONTRACTOR TO VERIFY ALL QUANTITIES. IN CASE OF DISCREPANCIES, GRAPHICALLY SHOWN QUANTITIES SHALL TAKE PRECEDENCE.
- ALL PLANT MATERIAL SHALL BE INSTALLED PLUMB AND PER THE SPECIFICATIONS CONTAINED WITHIN THE CONTRACT DOCUMENTS. ANY NECESSARY STAKING AND/OR OTHER SUPPORTS MATERIALS/METHODS SHALL BE SUBMITTED TO THE LANDSCAPE ARCHITECT FOR REVIEW AND APPROVAL PRIOR TO INSTALLATION.
- THE CONTRACTOR SHALL PRUNE EXISTING AND/OR NEW TREES ONLY PER LANDSCAPE ARCHITECT DIRECTION.
- THE CONTRACTOR SHALL STAKE THE LOCATIONS OF ALL TREES AND B&B SHRUBS FOR LANDSCAPE ARCHITECT REVIEW AND APPROVAL, PRIOR TO INSTALLATION.
- ALL ROOT-WRAPPING MATERIALS THAT ARE NOT BIO-DEGRADABLE SHALL BE REMOVED FROM THE ROOT BALL. ROOT BALLS SHALL BE FREE OF WEEDS.
- SPECIFIED PLANT MATERIAL SIZES SHALL BE CONSIDERED MINIMUM SIZES.
- FINISH GRADE OF PLANTING BEDS SHALL BE ONE (1) INCH BELOW ADJACENT FLATWORK, UNLESS SPECIFIED OTHERWISE.
- MULCH OR PLANTING BED DRESSING SHALL BE PLACED IN ALL PLANTING AREAS AS SPECIFIED. MULCH OR PLANTING BED DRESSING SHALL NOT BE PLACED WITHIN SIX (6) INCHES OF TREE TRUNKS. MULCHING SHOULD BE REPEATED ANNUALLY DURING THE AUTUMN TO A THREE (3) INCH DEPTH.
- ALL PLANT MATERIAL SHOULD RECEIVE AN ORGANIC FERTILIZER IN LIMITED APPLICATION FOLLOWING INSTALLATION. TYPE AND APPLICATION RATE AND METHOD OF APPLICATION TO BE SPECIFIED BY THE CONTRACTOR AND APPROVED BY THE LANDSCAPE ARCHITECT.
- EXCESS FERTILIZER SHALL BE DISPOSED OF PROPERLY OFF-SITE. IT SHALL NOT BE DISPOSED OF IN STORM DRAINS AND/OR DRYWELLS.
- STOCKPILED PLANT MATERIAL TO BE PLACED IN THE SHADE AND PROPERLY HAND-WATERED UNTIL PLANTED.
- MINI-NUGGET TYPE DECORATIVE BARK MULCH WILL BE USED TO RETURN NUTRIENTS TO THE SOIL, REDUCE MAINTENANCE AND MINIMIZE EVAPORATION FOR AREAS APPROXIMATE TO THE RESIDENCE. LARGER SHREDDED BARK MULCH WILL BE USED FOR STEEP AREAS SO SLOUGHING IS LESS LIKELY TO OCCUR.
- PRESERVE & PROTECT ALL EXISTING VEGETATION INDICATED TO REMAIN AT ALL TIMES.
- ALL VEGETATION PROPOSED FOR OUTSIDE THE BUILDING ENVELOPE TO BE NATIVE UNLESS OTHERWISE NOTED. PLANTING THAT OCCURS OUTSIDE THE BUILDING ENVELOPE IS FOR RESTORATION PURPOSES ONLY OR IS SPECIFIC TO UTILITIES RESTORATION.
- SIX (6) INCH PLANT MIX SHALL BE PROVIDED FOR ALL LAWN, TURF, AND NATIVE PLANTING ZONES. 18 INCH PLANT MIX SHALL BE PROVIDED FOR ALL PERENNIAL PLANTING BEDS UNLESS OTHERWISE NOTED.
- ALL PLANT MATERIAL SHALL BE FLORIDA GRADE #1 OR BETTER AS OUTLINED IN GRADES AND STANDARDS FOR NURSERY PLANTS, PARTS I AND II OF THE LATEST EDITION, PUBLISHED BY THE FLORIDA DEPARTMENT OF AGRICULTURE AND CONSUMER SERVICES.

CITY OF MIAMI BEACH LANDSCAPE LEGEND

CITY OF MIAMI BEACH
LANDSCAPE LEGEND

INFORMATION REQUIRED TO BE PERMANENTLY AFFIXED TO PLANS
Drawing Date: 05-4 Lot Area: 8,916 Acres: 20

SPACES	REQUIRED	ALLOWED	PROVIDED
A. Square feet of ground (Open Space in industrial or strip plan lot area) <u>8,916</u> x <u>02</u> % = <u>802</u> sq ft	<u>802</u>	<u>802</u>	<u>4,204</u>
B. Square feet of parking lot spaces required as indicated on the plan: Number of parking spaces: <u>NA</u> x 315 sq ft parking space =	<u>NA</u>	<u>NA</u>	<u>NA</u>
C. Total square feet of landscaped open space required: A+B	<u>802</u>	<u>802</u>	<u>4,204</u>
LAWN AREA CALCULATION			
A. Square feet of landscaped open space required	<u>802</u>	<u>802</u>	<u>4,049</u>
B. Maximum lawn area (leaf permitted) <u>50</u> % = <u>4,204</u>	<u>2,102</u>	<u>2,107</u>	
TREES			
A. Number of trees required per lot or net acre, less existing number of trees meeting minimum requirements	<u>8</u>	<u>18</u>	
B. <u>0</u> trees <u>NA</u> % of lot area - number of existing trees	<u>6</u>	<u>18</u>	
C. % Low maintenance / drought and salt tolerant required: Number of trees provided: 35%	<u>6</u>	<u>18</u>	
D. Street trees (minimum average spacing of 30' o.c.) <u>NA</u> trees/lot along street divided by 35% =	<u>NA</u>	<u>NA</u>	
E. Street trees spaced allowed directly across power lines (minimum average spacing of 30' o.c.) <u>55</u> trees/lot along street divided by 35% =	<u>3</u>	<u>3</u>	
SHRUBS			
A. Number of shrubs required: Sum of lot and street trees required x 125%	<u>144</u>	<u>283</u>	
B. % Native shrubs required: Number of shrubs provided x 50%	<u>142</u>	<u>151</u>	
LAWN SHRUBS OR SMALL TREES			
A. Number of large shrubs or small trees required: Number of required shrubs x 250%	<u>15</u>	<u>124</u>	
B. % Native large shrubs or small trees required: Number of large shrubs or small trees provided x 50%	<u>8</u>	<u>124</u>	

*50% for Residential Low Tree Requirements
5 trees = 1 tree for every 1,000 square feet for lots over 6,000 square feet total.

PLANTING SCHEDULE

ABB.	QUANTITY	BOTANICAL NAME	COMMON NAME	SPECIFICATIONS
TREES				
CUV	2	COCCOLOBA UNIFERA	SEAGRAPE	MULTI-LEADER 16 FT. CA. HT.
MFR	3	MYRCANTHES FRAGRANS	SIMPSON'S STOPPER	4 IN. DBH. 16 FT. CA. HT.
BBI	1	BURSEPA SIMARUBA	GUMBO LIMBO	4 IN. DBH. 16 FT. CA. HT.
CER	12	CONOCARPUS ERECTUS	GREEN BUTTWOOD	4 IN. DBH. 16 FT. CA. HT.
PALMS				
CM	10	CARYOTA MITIS	FISHTAIL PALM	FG. CLUMP. 16 FT. CA. HT.
LDI	6	LIVISTONA DECORA	RIBBON FAN PALM	FG. 16 FT. CA. HT. SINGLE
UNDERSTORY TREES & SHRUBS				
GL	124	GYMNANTHES LUCCIDA	CRABWOOD	7 GAL. 3 FT. HT.
CL	27	CROTON LINEARIS	PINELAND CROTON	3 GAL.
HC	20	HEDYCHUM CORONARIUM	WHITE GINGER LILY	3 GAL.
CZ	50	CALATHEA ZEBRINA	ZEBRRA PLANT	3 GAL.
PW	35	PHILODENDRON WILSONII	SAME	3 GAL.
BB	16	ANTHURUM BIG RED BIRD	BIRDS NEST ANTHURUM	3 GAL.
RE	5	RHAPIS EXCELSA	LADY PALM	3 GAL.
NC	6	NEOMARICA CAERULEA REGINA	IRIS GIANT APOSTOLE	3 GAL.
GROUNDCOVERS				
TM	120	TRADESCANTIA MICROFOLIA	ARGENTINE IVY	1 GAL. 18 IN. O.C.
LM	470	LIRIOPE MUSCARI	LILYTURF	1 GAL. 18 IN. O.C.
MISC.				
ALL SOD AREAS TO BE REPLACED WITH ZOYSIA ZEON				
LANDSCAPE ARCHITECT TO HAVE \$2000 WHOLESALE ACCENT PLANT ALLOWANCE				
SECOND LEVEL PLANTERS TO BE FILLED WITH PERUVIAN GRAY BEACH PEBBLES				



PLANT REFERENCE IMAGES



COCCOLOBA UNIFERA MYRCANTHES FRAGRANS MYRCANTHES FRAGRANS (MULTI-TRUNK) CARYOTA MITIS LIVISTONA DECORA BURSEPA SIMARUBA

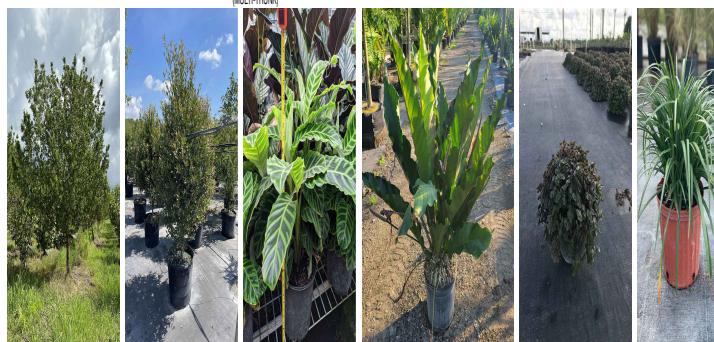

CONOCARPUS ERECTUS GYMNANTHES LUCCIDA CALATHEA ZEBRINA ANTHURUM BIG RED BIRD TRADESCANTIA MICROFOLIA LIRIOPE MUSCARI



CROTON LINEARIS HEDYCHUM CORONARIUM NEOMARICA CAERULEA REGINA PHILODENDRON WILSONII RHAPIS EXCELSA

LOT 10 GARDEN
11500 BAY DRIVE | MIAMI BEACH, FLORIDA 33154

SEAL (S TYLER NIELSEN - LABR1701)



07.02.2025

PLANTING SCHEDULE & NOTES

DATE	ISSUE
05.17.2023	50% CD
06.21.2023	50% CD
07.19.2023	75% CD
07.25.2024	75% CD
02.28.2024	100% CD
01.13.2025	COORDINATION
07.02.2025	DWG SUBMITTAL

L700

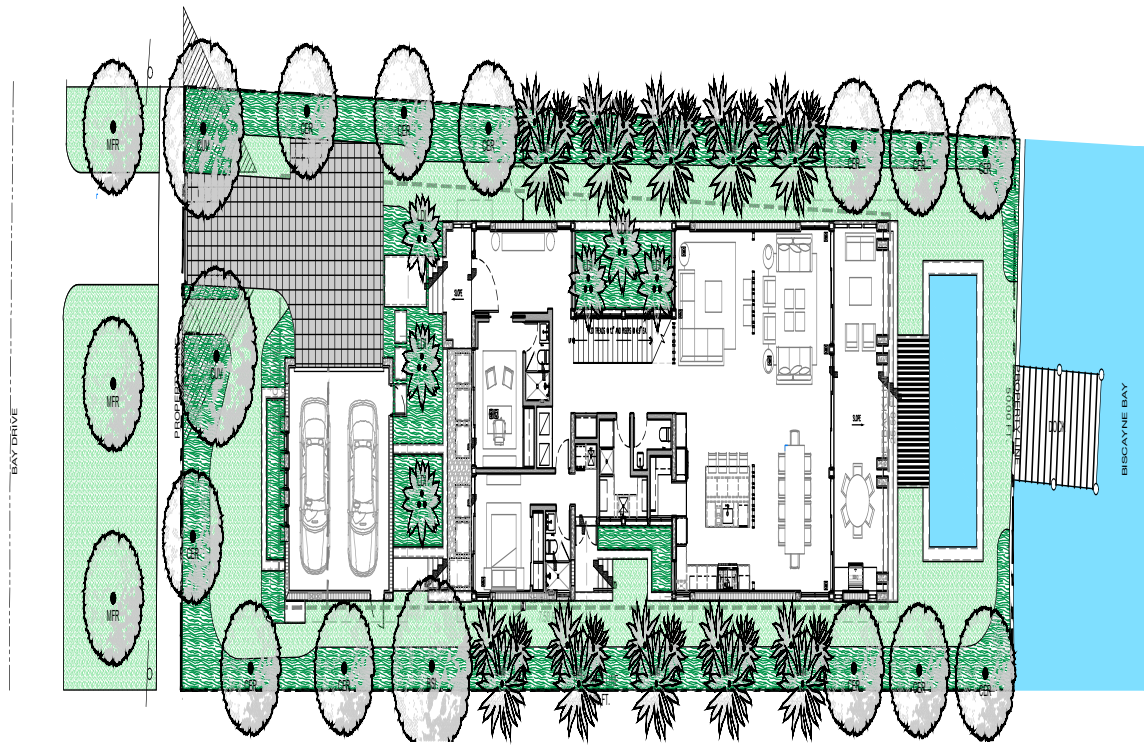

NIELSEN
landscape architects

1447 cypress drive, 2
jupiter, FL 33469
561.402.9414

www.nielsenlandarch.com

LOT 10 GARDEN
1180 BAY DRIVE | MIAMI BEACH, FLORIDA 33141

PLANTING SCHEDULE

ABB.	QUANTITY	BOTANICAL NAME	COMMON NAME	SPECIFICATIONS
TREES				
CLV	2	COCCOLOBA UVIFERA	SEAGRAPE	MULTI-LEADER 18 FT. OA. CA
MFR	3	MYRCIANTHES FRAGRANS	SIMPSON'S STOPPER	4 IN. DBH. 16 FT. OA. HT.
BSI	1	BURSERA SIMARUBA	GUMBO LIMBO	4 IN. DBH. 16 FT. OA. HT.
CER	12	CONOCARPUS ERECTUS	GREEN BUTTWOOD	4 IN. DBH. 16 FT. OA. HT.
PALMS				
CM	10	CARYOTA MITIS	FISHTAIL PALM	FG. CLUMP. 16 FT. OA. HT
LDI	6	LIVISTONA DECORA	RIBBON FAN PALM	FG. 16 FT. OA. HT. SINGLE

PLANTING LEGEND



SEAL (S TYLER NIELSEN - LAB0707)

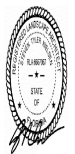

07.02.2025

TREE & PALM PLANTING PLAN

DATE	ISSUE
05.07.2023	25% CD
06.21.2023	50% CD
07.19.2023	75% CD
07.25.2024	75% CD
02.28.2024	100% CD
01.13.2025	COORDINATION
07.02.2025	DRS SUBMITTAL



L701

© COPYRIGHT NIELSEN LANDSCAPE ARCHITECTS, LLC

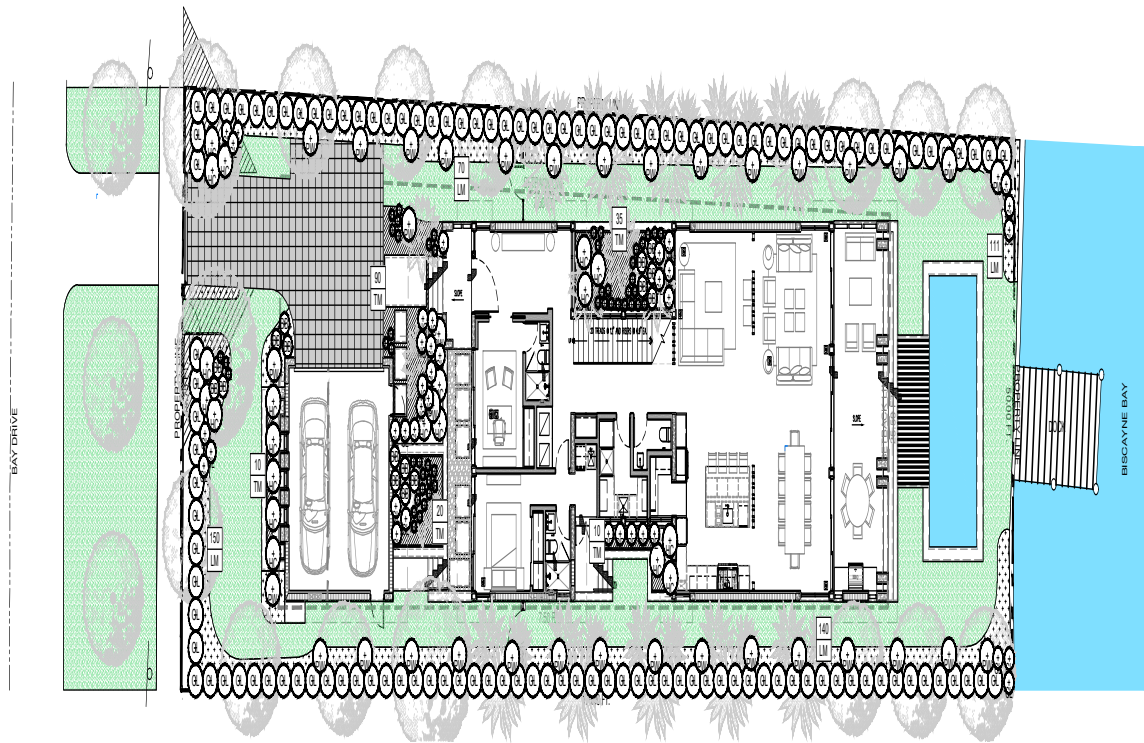

NIELSEN
Landscape architects

1447 cypress drive, 2
jupiter, fl 33469
561.402.9414

www.nielsenlandarch.com

LOT 10 GARDEN
1180 BAY DRIVE | MIAMI BEACH, FLORIDA 33141

PLANTING SCHEDULE

UNDERSTORY TREES & SHRUBS			
GL	124	GYMNANTHES LUCIDA	CRABWOOD 25 GAL. 6 FT. HT.
CL	27	CROTON LINEARIS	PINELAND CROTON 7 GAL.
HC	20	HEDYCHUM CORONARIUM	WHITE GINGER LILY 7 GAL.
CZ	50	CALATHEA ZEBRINA	ZEBRA PLANT 3 GAL.
PW	35	PHILODENDRON WILSONII	SAME 7 GAL.
BB	16	ANTHURUM BIG RED BIRD	BIRDS NEST ANTHURUM 7 GAL.
RE	5	RHAPIS EXCELSA	LADY PALM 7 GAL.
NC	6	NEOMARICA CAERULEA 'REGINA'	IRIS GIANT APOSTOLE 3 GAL.
GROUNDCOVERS			
TM	120	TRADESCANTIA MICROPOLIA	ARGENTINE IVY 3 GAL. 18 IN. O.C.
LM	470	LIRIOPE MUSCARI	LILYTURF 3 GAL. 18 IN. O.C.

PLANTING LEGEND

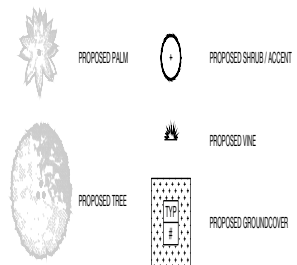

SEAL (S TYLER NIELSEN - LAB6707)

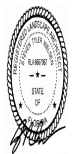

07.02.2025

UNDERSTORY PLANTING PLAN

DATE	ISSUE
05.17.2023	25% CD
06.21.2023	50% CD
07.19.2023	75% CD
07.25.2024	75% CD
02.28.2024	100% CD
01.13.2025	COORDINATION
07.02.2025	DRS SUBMITTAL



L702

COPYRIGHT NIELSEN LANDSCAPE ARCHITECTS, LLC

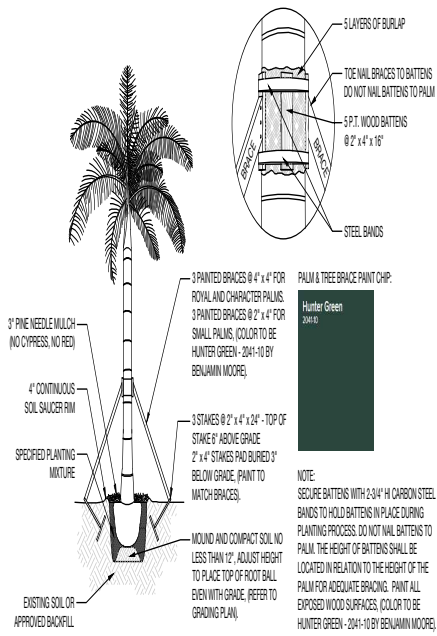

1 PALM PLANTING AND STAKING DETAIL
SCALE: 3/32" = 1'-0"

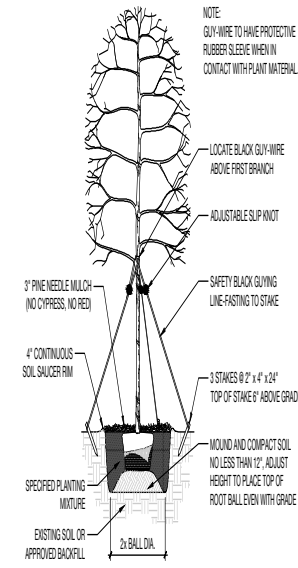

2 UNDERSTORY TREE PLANTING AND STAKING DETAIL
SCALE: 3/32" = 1'-0"

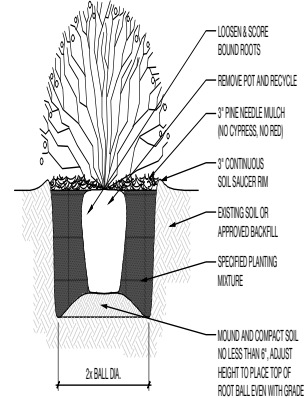

3 SHRUB PLANTING DETAIL
SCALE: 3/32" = 1'-0"

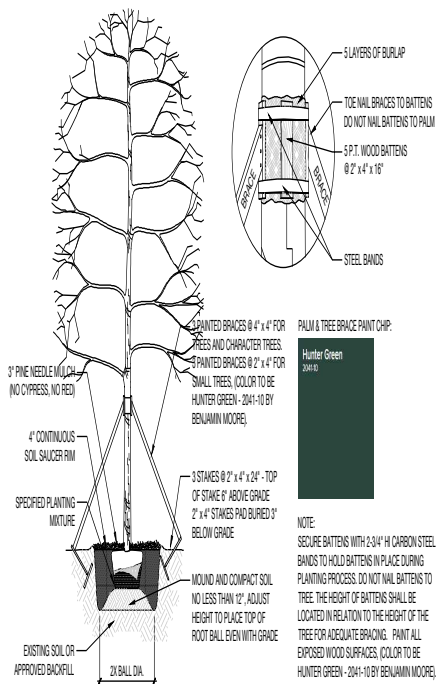

4 TREE PLANTING AND STAKING DETAIL
SCALE: 3/32" = 1'-0"

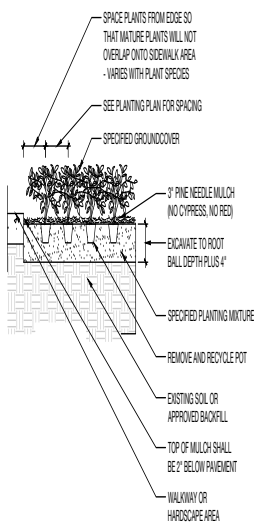

5 GROUND COVER PLANTING DETAIL
SCALE: 3/32" = 1'-0"

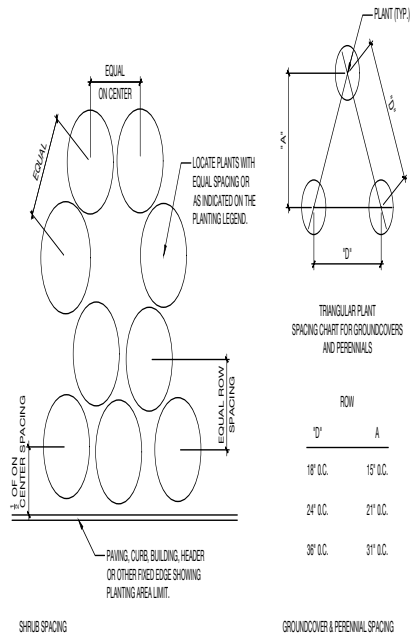

6 PLANT & SHRUB SPACING DETAIL
SCALE: 3/32" = 1'-0"



LOT 10 GARDEN
11500 BAY DRIVE | MIAMI BEACH, FLORIDA 33141

SEAL (S) TYLER NIELSEN - LABR1701

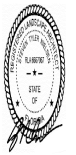

07.08.2025

PLANTING DETAILS

DATE	ISSUE
05.17.2023	25% CD
06.21.2023	50% CD
07.19.2023	75% CD
07.25.2024	75% CD
02.28.2024	100% CD
01.13.2025	COORDINATION
07.08.2025	DRS SUBMITTAL

SCALE AS NOTED

L703

© COPYRIGHT NIELSEN LANDSCAPE ARCHITECTS, LLC

IRRIGATION NOTES

- THE PLANS AND DRAWINGS ARE DIAGRAMMATIC OF THE WORK TO BE PERFORMED. SOME COMPONENTS MAY BE SHOWN OUTSIDE THE WORK AREA FOR CLARITY. THE WORK SHALL BE EXECUTED IN A MANNER TO AVOID CONFLICTS WITH UTILITIES AND OTHER ELEMENTS OF CONSTRUCTION, INCLUDING LANDSCAPE MATERIALS. ALL DEVIATIONS FROM THE PLANS SHALL BE APPROVED BY THE OWNERS REPRESENTATIVE BEFORE BEING INSTALLED.
- THE IRRIGATION SYSTEM SHALL BE INSTALLED IN ACCORDANCE WITH THE PLANS, IRRIGATION SYSTEM SPECIFICATIONS AND ALL CONTRACT DOCUMENTS. THE CONTRACTOR SHALL COMPLY WITH ALL CURRENT LOCAL CODES, ORDINANCES AND REGULATIONS.
- ALL IRRIGATION MAINLINE AND LATERAL LINES ARE TO NOT EXCEED A VELOCITY OF 5 FPS.
- THE CONTRACTOR SHALL NOT WILLFULLY INSTALL ANY ASPECT OF THE IRRIGATION SYSTEM AS SHOWN ON THE PLANS AND DRAWINGS, WHEN IT IS OBVIOUS IN THE FIELD THAT OBSTRUCTIONS, SPACE REQUIREMENTS, OR DISCREPANCIES EXIST THAT WOULD NOT HAVE BEEN KNOWN DURING THE DESIGN OF THE IRRIGATION SYSTEM. IN THE EVENT THAT NOTIFICATION OF THE CONFLICT IS NOT APPROVED BY THE OWNERS REPRESENTATIVE, THE CONTRACTOR WILL ASSUME FULL RESPONSIBILITY FOR ALL REVISIONS.
- REFER TO THE LANDSCAPE PLANS WHEN TRENCHING TO AVOID TREE ROOT BALLS WHEN INSTALLING IRRIGATION EQUIPMENT. CALL 811 AND REFER TO UTILITY PLANS PRIOR TO TRENCHING.
- IRRIGATION CONTRACTOR SHALL VERIFY ALL SITE CONDITIONS, INCLUDING UTILITY LOCATIONS BEFORE INSTALLATION OF THE IRRIGATION SYSTEM. THE CONTRACTOR IS RESPONSIBLE FOR CORROBORATING INSTALLATION WITH ALL OTHER CONSTRUCTION ON SITE, ESPECIALLY LANDSCAPE INSTALLATION. THE IRRIGATION SYSTEM SHALL BE RELOCATED AT NO ADDITIONAL COST FOR ANY CONFLICT WITH LANDSCAPE INSTALLATION OR ANY OTHER SITE CONSTRUCTION OR EXISTING CONDITIONS.
- VERIFY THE REQUIRED MINIMUM STATIC WATER PRESSURE IS AVAILABLE AT THE PROJECT SITE PRIOR TO BEGINNING THE IRRIGATION INSTALLATION. NOTIFY THE IRRIGATION DESIGN CONSULTANT AND LANDSCAPE ARCHITECT IN WRITING IF THE MINIMUM STATIC WATER PRESSURE OR WATER VOLUME IS NOT AVAILABLE. SEE PLAN SHEET FOR REQUIREMENTS.
- WHERE EXISTING OR NEW TREES, LIGHT FIXTURES, SIGNS, ELECTRONIC CONTROLLERS AND/OR OTHER OBJECTS ARE AN OBSTRUCTION TO AN IRRIGATION SPRINKLER'S PATTERN, THE COMPONENT AND PIPING SHALL BE RELOCATED AS NECESSARY TO OBTAIN PROPER COVERAGE OF AN IRRIGATION SPRINKLER'S PATTERN. THE COMPONENT AND PIPING SHALL BE RELOCATED AS NECESSARY TO OBTAIN THE PROPER COVERAGE WITHOUT DAMAGING THE OBSTRUCTION.
- 100% HEAD-TO-HEAD COVERAGE IS REQUIRED. ASSURE THAT ANY UNEXPECTED SPACING DOES NOT EXCEED THE SPACING SHOWN IN THE PLANS.
- IRRIGATION CONTRACTOR SHALL ADJUST ALL SPRINKLERS TO AVOID OVER SPRAY ONTO IMPERVIOUS AREAS.
- ALL MATERIALS AND EQUIPMENT SHOWN SHALL BE NEW AND INSTALLED AS SHOWN ON THE PLANS. IF THE DRAWINGS DO NOT THOROUGHLY DESCRIBE THE TECHNIQUES TO BE USED, THE INSTALLER SHALL FOLLOW THE INSTALLATION METHODS AND INSTRUCTIONS RECOMMENDED BY THE PRODUCT MANUFACTURER.
- THE LOCATION OF THE IRRIGATION MAINLINE SHALL BE IDENTIFIED IN THE FIELD AND APPROVED BY THE OWNERS REPRESENTATIVE BEFORE INSTALLATION.
- CONTRACTOR IS TO SUBMIT PRODUCT SPECIFICATION SHEETS FOR ALL IRRIGATION EQUIPMENT TO BE USED FOR APPROVAL BY THE LANDSCAPE ARCHITECT PRIOR TO INSTALLATION.
- THE QUANTITIES SHOWN IN THE LEGEND SHEETS SHALL NOT BE USED FOR BIDDING PURPOSES. THE CONTRACTOR WILL BE RESPONSIBLE FOR CONDUCTING A COMPREHENSIVE MATERIALS TAKEOFF TO DETERMINE THE ACTUAL QUANTITIES OF MATERIAL NECESSARY TO EXECUTE THE WORK DESCRIBED IN THE DOCUMENTS.
- ALL TRENCHES SHALL BE BACKFILLED WITH CLEAN DEBRIS FREE MATERIALS.
- IRRIGATION CONTRACTOR IS TO INSTALL CHRISTY ZONE TAGS WITH THE CORRESPONDING CONTROLLER ZONE NUMBER AT EACH CONTROL VALVE.
- AS BUILT DOCUMENTS ARE TO BE PROVIDED TO THE OWNER UPON COMPLETION OF THE PROJECT, THE MAINLINE, CONTROL VALVES, ISOLATION VALVES, GROUND ROGS AND SPICE BOXES SHALL BE LOCATED WITH A MEASUREMENT FROM TWO FIXED POINTS.
- IRRIGATION CONTRACTOR SHALL SECURE ANY AND ALL NECESSARY PERMITS FOR THE WORK PRIOR TO COMMENCEMENT OF ON-SITE OPERATIONS.
- A MAINLINE PRESSURE TEST IS TO BE CONDUCTED BEFORE BACKFILLING. ALL FINDINGS ARE TO BE REPORTED TO THE LANDSCAPE ARCHITECT WITHIN TWENTY FOUR HOURS POST TEST.
- ALL SLEEVES ARE TO BE TWO TIMES THE SIZE OF THE PIPE.
- ROUTE AN ELECTRICAL CONDUIT FROM THE CONTROLLER TO THE MAINLINE TRENCH FOR THE CONTROL WIRES. THE CONDUIT AND CONTROL WIRES PARALLEL TO THE MAINLINE.
- THE IRRIGATION SYSTEM IS TO BE INSPECTED AND APPROVED BY THE PROJECT OWNER PRIOR TO RECEIVING CERTIFICATION.
- ANY PRODUCT SUBSTITUTIONS MADE BY THE IRRIGATION CONTRACTOR ARE TO BE REVIEWED AND APPROVED BY THE OWNER PRIOR TO INSTALLATION.

DRIP SPECIFICATIONS & NOTES:

DRIP TUBING, SPECIFICATION AS SHOWN ON THE PRODUCT SCHEDULE. DRIP GRID LAY-OUT IS BASED ON 30 PSI.

- INSTALL DRIP SYSTEM IN THE FOLLOWING ORDER: A) WITH ALL MAINLINE AND ITS ASSOCIATE EQUIPMENT (INCLUDING PRE-FILTERING 100 MESH FILTER AT P.O.C.) COMPLETELY INSTALLED, FLUSH MAINLINE TILL FREE AND CLEAR OF DEBRIS. B) INSTALL ALL LATERALS TO THE VARIOUS DRIP GRIDS, AND SUPPLY HEADERS WITH RISERS EXTENDED ABOVE GROUND. CENTER FEED RISERS, TEMPORARY EXTEND NIPPLES WITH PIPE AND COUPLINGS (DO NOT GLUE). FLUSH TILL FREE AND CLEAR OF DEBRIS. TEMPORARY CAP NIPPLES, SEAL BLANK TUBING (RISERS) WITH TAPE. C) INSTALL EXHAUST HEADERS - RISERS - FLUSH POINTS. D) INSTALL DRIP GRID, STAPLE TUBING PER DETAIL, CONNECT DRIP TUBING TO SUPPLY HEADER RISERS. FLUSH TILL FREE AND CLEAR OF DEBRIS. E) CONNECT DRIP GRID TO EXHAUST HEADER RISERS, FLUSH SYSTEM USING FLUSH POINT.
- INSTALL OPERATION INDICATORS WITHIN 12-INCHES OF FLUSH POINT VALVE BOX. SEE DETAIL. ACTIVATE DRIP ZONE, ENSURE ALL OPERATION INDICATORS ARE FULLY EXTENDED, ADJUST STREAM SPRAY TO WHERE IT CAN EASILY BE SEEN BY MAINTENANCE PERSON.
- PRESSURE TEST WITH OWNERS REPRESENTATIVE PRESENT: PER ZONE, TEMPORARY INSTALL (2) PRESSURE GAUGES (LIQUID FILLED PRESSURE GAUGES ON (2) FLUSH POINTS, (1) ON LARGEST GRID FLUSH POINT AND THE OTHER ON FARTHEST GRID FLUSH POINT). ACTIVATE ZONE. AFTER FLOW HAS STABILIZED, VERIFY ALL ZONE OPERATION INDICATORS ARE FULLY EXTENDED, CHECK PRESSURE ON BOTH GAUGES. PRESSURE MUST BE 20 PSI OR HIGHER TO PASS TEST. IF TEST FAILS, CONTRACTOR TO LOCATE AND CORRECT PROBLEM AND RETEST. IT IS IN THE CONTRACTORS BEST INTEREST TO PERFORM HIS OWN TEST BEFORE HE CALLS OWNERS REPRESENTATIVE PRESENTS TO AVOID RE-INSPECTION FEES.
- PRESSURE TEST RESULTS SHALL BE NOTED AS-BUILT DRAWING BY THE 'FLUSH POINT' WHERE TESTS WERE TAKEN. ALL 'FLUSH POINTS' LOCATIONS SHALL BE INCLUDED IN AS-BUILT DRAWINGS.

THE FOLLOWING PRODUCTS ARE NOT SHOWN ON THE PLAN FOR GRAPHIC CLARITY BUT ARE TO BE INCLUDED DURING THE BIDDING PROCESS AND ARE TO BE INSTALLED BY THE IRRIGATION INSTALLATION CONTRACTOR. FOLLOW ALL MANUFACTURERS SPECIFICATIONS AND RECOMMENDATIONS.

- FLUSH VALVES (MANUAL OR AUTOMATIC).
- AIR RELIEF VALVES - LOCATE AT THE HIGHPOINT OF THE ZONE.
- DRIP INDICATOR HEAD - LOCATE IN AN INCONSPICUOUS AREA BUT ACCESSIBLE BY THE SITE MAINTENANCE TEAM.

CRITICAL ANALYSIS

Generated: 2024-02-09 12:14

P.O.C. NUMBER: 01
Water Source Information: RECORD ALL BAGGER DISC METER OR EQUAL PROVIDED BY OTHERS.

FLOW AVAILABLE
Water Meter Size: 1"
Flow Available: 37.5 GPM

PRESSURE AVAILABLE
Static Pressure at P.O.C.: 60 PSI
Elevation Change: 0.00 ft
Service Line Size: 3"
Length of Service Line: 10ft
Pressure Available: 60 PSI

DESIGN ANALYSIS
Maximum Station Flow: 22.95 GPM
Flow Available at P.O.C.: 37.5 GPM
Residual Flow Available: 14.58 GPM

Critical Station: 5
Design Pressure: 30 PSI
Friction Loss: 0.89 PS
Fittings Loss: 0.09 PS
Elevation Loss: 0 PSI
Loss through Valve: 3.7 PSI
Pressure Req. at Critical Station: 34.7 PSI
Loss for Fittings: 0.09 PS
Loss for Main Line: 0.94 PS
Loss for P.O.C. to Valve Elevation: 0.95 PS
Loss for Backflow: 12 PSI
Loss for Water Meter: 3.08 PS
Critical Station Pressure at P.O.C.: 58.8 PSI
Pressure Available: 60 PSI
Residual Pressure Available: 9.2 PSI

LATERAL LEGEND

Color	Size
Green	1"
Blue	1.5"
Red	2"
Orange	2.5"

SLEEVE LEGEND

LATERAL/MAINLINE SIZE	SLEEVE SIZE
1"	2"
1.5"	3"
2"	4"
2.5"	4"
3"	6"
4"	8"
CONTROL WIRE CONDUIT	2"

IRRIGATION SCHEDULE

SYMBOL	MANUFACTURER/MODEL/DESCRIPTION	QTY	PSI
	RAIN BIRD 1800-UPRS 30 SERIES TURF SPRAY INLET POP-UP SPRINKLER WITH CO-MOLDED WIPER SEAL, SIDE AND BOTTOM INLET, 1/2IN. NPT FEMALE THREADED INLET, PRESSURE-REGULATING.	12	30
	RAIN BIRD 1800-UPRS 15 STRIP SERIES TURF SPRAY INLET POP-UP SPRINKLER WITH CO-MOLDED WIPER SEAL, SIDE AND BOTTOM INLET, 1/2IN. NPT FEMALE THREADED INLET, PRESSURE-REGULATING.	22	30
	RAIN BIRD 1800-UPRS US SERIES TURF SPRAY INLET POP-UP SPRINKLER WITH CO-MOLDED WIPER SEAL, SIDE AND BOTTOM INLET, 1/2IN. NPT FEMALE THREADED INLET, PRESSURE-REGULATING.	19	30
	RAIN BIRD 1800-UPRS U10 SERIES TURF SPRAY INLET POP-UP SPRINKLER WITH CO-MOLDED WIPER SEAL, SIDE AND BOTTOM INLET, 1/2IN. NPT FEMALE THREADED INLET, PRESSURE-REGULATING.	8	30
	RAIN BIRD 1800-UPRS HE-WN SERIES TURF SPRAY INLET POP-UP SPRINKLER WITH CO-MOLDED WIPER SEAL, SIDE AND BOTTOM INLET, 1/2IN. NPT FEMALE THREADED INLET, PRESSURE-REGULATING.	13	30
	RAIN BIRD 1800-1400 FLOOD FIXED FLOW RATE 1.25 GPM - 2.0 GPM FULL CIRCLE BUBBLER, 1/2IN. RPT.	82	30

SYMBOL	MANUFACTURER/MODEL/DESCRIPTION	QTY	PSI	RADIUS
	RAIN BIRD 500R-PC14 1.0 TURF ROTOR, 4IN. POP-UP, PLASTIC RISER, ADJUSTABLE TO FULL CIRCLE, LOW ANGLE NOZZLE.	6	25	25'

SYMBOL	MANUFACTURER/MODEL/DESCRIPTION	QTY
	RAIN BIRD K12 150 L/S HIGH FLOW CONTROL ZONE KIT FOR LARGE COMMERCIAL DRIP ZONES - 1/2IN. PEBB GLOBE VALVE WITH SINGLE 1-1/2IN. PRESSURE REGULATING OPEE CHECK BASKET FILTER, FLOW RANGE: 15-60 GPM.	2
	RAIN BIRD KFS-30-12 1/2 SUB-SURFACE PRESSURE COMPENSATING DRPLINE W/ COPPER SHIELD TECHNOLOGY, 0.6 GPM EMITTERS AT 12" O.C. LATERALS SPACED AT 12' APART, WITH EMITTERS OFFSET FOR TRIANGULAR PATTERN, UV RESISTANT. SPECIFY IF INSERT FITTINGS.	2,381 L.F.

SYMBOL	MANUFACTURER/MODEL/DESCRIPTION	QTY
	RAIN BIRD PEB 1IN., 1-1/2IN., 2IN. PLASTIC INDUSTRIAL VALVES, LOW FLOW OPERATING CAPABILITY, GLOBE CONFIGURATION.	5
	LANDSCAPE PRODUCTS INC. CWI SLP SOCKET 1/2IN., 3/4IN., 1IN., 1-1/4IN., 1-1/2IN., 2IN. SLP SOCKET PLASTIC BALL VALVE QUARTER-TURN SHUTOFF DESIGNED FOR IRRIGATION, SPAS, POOLS AND OTHER GENERAL COLD WATER APPLICATIONS. 125 PSI RATING SAME SIZE AS MAINLINE.	1
	ZURN 675SL 1/2 REDUCED PRESSURE BACKFLOW DEVICE	1
	RAIN BIRD ESP-3MS 10 STATION HYBRID TURIN SHUTOFF CONTROLLER FOR RESIDENTIAL OR LIGHT COMMERCIAL USE, LINK WIFI MODULE AND FLOW SENSOR READY.	1
	RAIN BIRD UNWIFI UPGRADES CONTROLLERS (ESP-4M, ESP-2ZE, ST8) TO HAVE 1 WEATHER DATA FOR ET-BASED ADJUSTMENTS (WATERSENSE APPROVED) & WIFI CAPABILITIES.	1
	RAIN BIRD RSD-REX RAIN SENSOR, WITH METAL LATCHING BRACKET, EXTENSION WIRE.	1
	WATER METER 1" RECORDALL BAGGER DISC METER OR EQUAL PROVIDED BY OTHERS.	1
	IRRIGATION LATERAL LINE PVC CLASS 200 SDR 21 SEE PIPE LEGEND FOR COLOR CODING AND SIZING.	1,621 L.F.
	IRRIGATION MAINLINE PVC CLASS 200 SDR 21	153.9 L.F.
	PIPE SLEEVE PVC SCHEDULE 40	68.0 L.F.

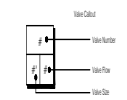

THE QUANTITIES SHOWN IN THE LEGEND SHEETS SHALL NOT BE USED FOR BIDDING PURPOSES. THE CONTRACTOR WILL BE RESPONSIBLE FOR CONDUCTING A COMPREHENSIVE MATERIALS TAKEOFF TO DETERMINE THE ACTUAL QUANTITIES OF MATERIAL NECESSARY TO EXECUTE THE WORK DESCRIBED IN THE DOCUMENTS.

VALVE SCHEDULE

NUMBER	MODEL	SIZE	TYPE	GPM	PRECIP
1	RAIN BIRD K12 150 L/S	1-1/2"	AREA FOR DRPLINE	19.59	1.44 in/h
2	RAIN BIRD PEB	1"	BUBBLER	14.5	1.78 in/h
3	RAIN BIRD PEB	1"	TURF SPRAY	21.02	1.93 in/h
4	RAIN BIRD PEB	1"	TURF ROTOR	4.38	0.69 in/h
5	RAIN BIRD PEB	1"	TURF SPRAY	22.95	1.81 in/h
6	RAIN BIRD PEB	1"	BUBBLER	16.5	1.8 in/h
7	RAIN BIRD K12 150 L/S	1-1/2"	AREA FOR DRPLINE	19.13	1.45 in/h

THE IRRIGATION CONTRACTOR IS TO SET THE RUN TIMES FOR EACH ZONE TO MATCH THE PLANT WATER REQUIREMENTS, SITE CONDITIONS AND MICRO-CLIMATE FACTORS. SEE THE LANDSCAPE PLANS FOR PLANT SPECIFICATIONS.



LOT 10 GARDEN
1120 BAY DRIVE | MIAMI BEACH, FLORIDA 33141

SEAL (S) TYLER NIELSEN - LA6607807

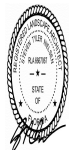

01.25.2024

IRRIGATION LEGENDS & NOTES

DATE	ISSUE
05.11.2023	25% CD
06.21.2023	50% CD
07.19.2023	75% CD
01.25.2024	100% CD



L800

©2019 BY NIELSEN LANDSCAPE ARCHITECTS, LLC

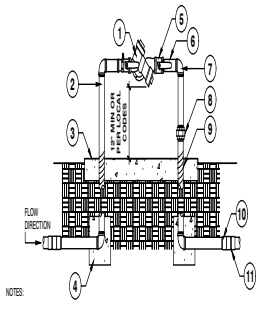

- NOTES:
1. ALL ASSEMBLY PARTS (THREADED NIPPLES, FITTINGS, ETC.) SHALL BE GALVANIZED OR BRASS PER LOCAL CODES AND REQUIREMENTS.
 2. GALVANIZED NIPPLE SHALL EXTEND 12" PAST THE EDGE OF THE CONCRETE FOOTING.
 3. SCH 80 PVC MALE ADAPTER SHALL BE USED IN CONNECTION FROM GALVANIZED TO THE MAINLINE.
 4. BACKFLOW PREVENTION DEVICE SHALL BE LOCATED AS CLOSE AS POSSIBLE TO THE LANDSCAPE WELTER.
 5. BACKFLOW PREVENTION DEVICE SHALL BE LOCATED IN PLANTING AREA UNLESS APPROVED BY OWNER'S REPRESENTATIVE.
 6. SEE DETAIL FOR BACKFLOW CASE INSTALLATION.
 7. ALL BACKFLOW PREVENTION DEVICES SHALL HAVE FREEZE BLANKET INCLUDED UPON INSTALLATION.
 8. ALL GALVANIZED CONNECTIONS SHALL TO BE MADE USING THREADED SEALANT. ALL SCH 80 PVC TO GALVANIZED CONNECTIONS TO BE MADE USING TEFLON TAPE.

- 1 BACKFLOW PREVENTION DEVICE (SEE IRRIGATION PLANS FOR MAKE AND MODEL). INSTALL DEVICE PER THE LOCAL WATER PURVEYOR'S STANDARDS AND SPECIFICATIONS.
- 2 GALVANIZED NIPPLE
- 3 4" THICK CONCRETE PAD, 1" ABOVE FINISHED GRADE. SEE BACKFLOW CASE DETAIL.
- 4 CONCRETE THIRST BLOCKS REQUIRED ON BACKFLOW DEVICES 12" AND LARGER.
- 5 BRASS BALL VALVE
- 6 THREADED GALVANIZED NIPPLE
- 7 GALVANIZED 90° DEGREE ELBOW
- 8 GALVANIZED UNION
- 9 WRAP IN MIL TAPE TWICE AROUND GALVANIZED PIPE UNDER FINISHED GRADE AND THROUGH THE CONCRETE
- 10 GALVANIZED COUPLING
- 11 SCH 80 PVC MALE ADAPTER

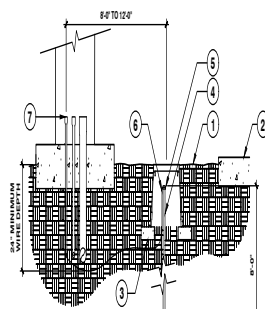

- NOTES:
1. ALL GROUNDING REQUIREMENTS FOR CONTROLLERS SHALL CONFORM TO LOCAL ELECTRICAL CODES.
 2. GROUNDING ROD SHALL NOT BE LOCATED IN THE SAME TRENCH AS IRRIGATION MAINLINES OR LATERAL LINES.
 3. VALVE BOX SHALL BE WRAPPED WITH A MINIMUM 3 MIL THICK PLASTIC AND SECURED TO THE VALVE BOX USING DUCT TAPE OR ELECTRICAL TAPE.
 4. INSTALL GROUNDING ROD PER THE CONTROLLER MANUFACTURER'S SPECIFICATIONS AND RECOMMENDATIONS.

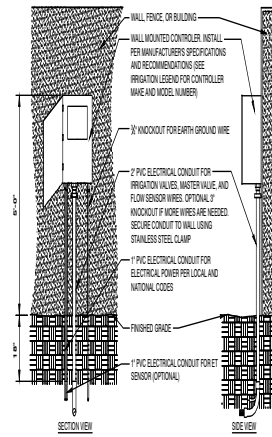

- NOTES:
1. COMMON AND CONTROLLER WIRE TO BE BUNDLED USING ELECTRICAL TAPE 1/2" ON CENTER.
 2. GROUNDING RODS SHALL BE 3/4" IN DIAMETER x 16' LENGTH. CONNECT THE GROUNDING ROD TO THE CONTROLLER USING 4 GAUGE BARE COPPER WIRE OR PER THE MANUFACTURER'S SPECIFICATIONS. SEE GROUNDING ROD DETAIL.
 3. ET STATION SHALL BE INSTALLED NO FLUPPER THAN 30' AWAY FROM THE CONTROLLER AND A MINIMUM OF 15' OFF THE GROUND, OUT FROM UNDER ANY OVERHEAD OBSTRUCTIONS SUCH AS, BUT NOT LIMITED TO, BUILDING OVERHANGS, TREES, OR UTILITIES.

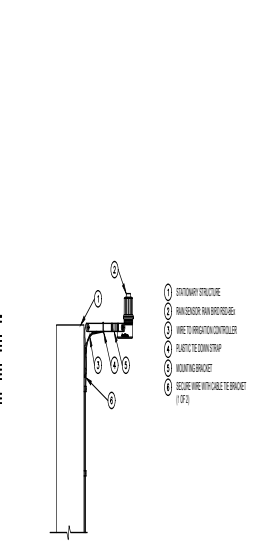

- 1 STATIONARY STRUCODE
- 2 HANGER BAR BRIDGES
- 3 WIRE TO IRRIGATION CONTROLLER
- 4 PLASTIC DRAIN STRIP
- 5 MOUNTING BRACKET
- 6 RESERVE WIRE WITH COUPLER BRACKET (1/2")

1 BACKFLOW PREVENTION DEVICE
3/4" x 1/2"

2 GROUNDING ROD
1" x 1/2"

3 WALL MOUNTED CONTROLLER
1/2" x 1/2"

4 RAIN BIRD - RSD-BEX RAIN SENSOR
N.T.S.

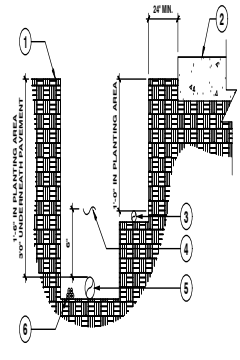

- NOTES:
1. SEE IRRIGATION LEGEND FOR MAINLINE AND LATERAL LINE PIPE SIZE AND TYPE.
 2. DIRECT BURIAL CONTROL WIRES SHALL BE INSTALLED IN SCH 40 PVC ELECTRICAL CONDUIT IF REQUIRED.
 3. 2 WIRE IRRIGATION WIRE SHALL BE INSTALLED IN SCH 40 PVC ELECTRICAL CONDUIT.
 4. DETECTABLE LOCATOR TAPE SHALL BE LOCATED SIX INCHES 81" ABOVE THE ENTIRE MAINLINE RUN.

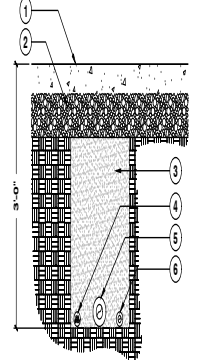

- NOTES:
1. SEE IRRIGATION LEGEND FOR MAINLINE SIZE AND TYPE.
 2. ALL SLEEVES SHALL BE SCH 40 PVC PIPE.
 3. ALL SLEEVES SHALL EXTEND 12" BEYOND THE EDGE OF PAVEMENT.
 4. END OF SLEEVES SHALL BE LOCATED WITH A WOODEN STAKE OR PVC PIPE. LOCATORS SHALL RUN CONTINUOUSLY FROM THE END OF THE SLEEVE TO FINISHED GRADE.

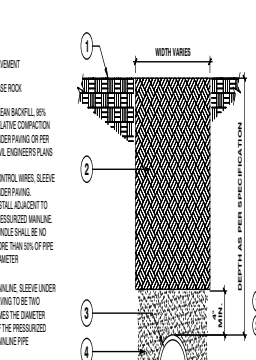

- 1 FINISHED GRADE
- 2 NATIVE SOIL BACKFILL COMPACT TO 95% COMPACTION
- 3 PVC MAINLINE
- 4 BACKFILL WITH 10% COARSE SAND, WATER, LET AND MECHANICALLY COMPACT TO 95% OPTIMUM DENSITY. ALLOW 48 HOURS TO SETTLE, AND BACKFILL AND COMPACT WITH NATIVE SOIL.

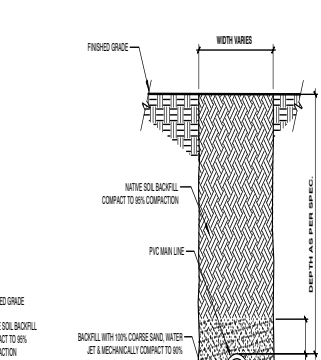

- 1 FINISHED GRADE
- 2 NATIVE SOIL BACKFILL COMPACT TO 95% COMPACTION
- 3 PVC MAINLINE
- 4 BACKFILL WITH 10% COARSE SAND, WATER, LET AND MECHANICALLY COMPACT TO 95% OPTIMUM DENSITY. ALLOW 48 HOURS TO SETTLE, AND BACKFILL AND COMPACT WITH NATIVE SOIL.

5 IRRIGATION TRENCHING
1 1/2" x 1/2"

6 PIPE BENEATH PAVEMENT
1" x 1/2"

7 MAINLINE WITH SAND BEDDING
1 1/2" x 1/2"

8 SLEEVE AT ROAD
1 1/2" x 1/2"

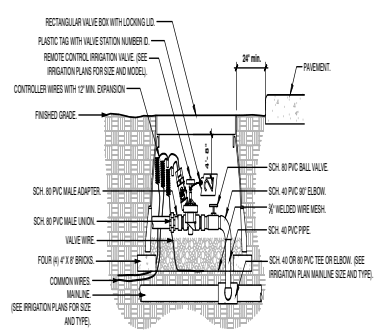

- NOTE:
1. LOCATE VALVE BOX WITHIN 24" OF PAVEMENT EDGE IN PLANTING AREA WHERE EASILY ACCESSIBLE WHENEVER POSSIBLE.
 2. COMMON WIRE AND CONTROLLER WIRE SHALL BE DIRECT BURIAL, 1/4 AWG OR LARGER, COLOR COMMON (WHITE), CONTROLLER WIRE FOR TURF (BLUE), AND CONTROLLER WIRE FOR SHRUBS (RED). (SEE SPECIFICATIONS FOR 2 WIRE CONTROLLERS).
 3. ALL WIRE RUNS SHALL BE CONTINUOUS WITHOUT ANY SPLICES UNLESS APPROVED BY THE OWNER'S REPRESENTATIVE. SEE SPLICE BOX DETAIL. WIRE CONNECTIONS SHALL BE MADE USING 3/8" x 4" CONNECTORS OR APPROVED EQUAL.
 4. VALVE BOX SHALL BE WRAPPED WITH MIN. 3 MIL THICK PLASTIC AND SECURE IT USING DUCT TAPE OR ELECTRICAL TAPE.
 5. MAINLINES 4" OR LARGER SHALL USE SADDLES AT THE CONNECTIONS POINTS TO THE IRRIGATION VALVE. (SEE SPECIFICATIONS FOR IRRIGATIONS SADDLES).
 6. ALL SCH 80 PVC TO SCH 40 PVC THREADED CONNECTIONS SHALL BE MADE USING TEFLON TAPE.
 7. VALVE BOXES SHALL BE LOCATED IN PLANTING AREAS.

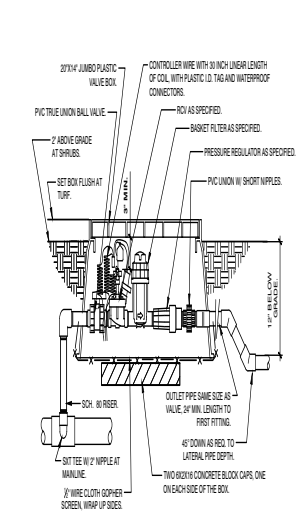

10 DRIP VALVE W/BASKET FILTER
1 1/2" x 1/2"

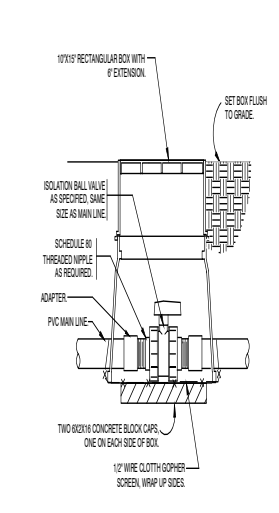

11 TRUE UNION BALL ISOLATION VALVE
N.T.S.



LOT 10 GARDEN
11200 BAY DRIVE | MIAMI BEACH, FLORIDA 33141

SEAL (S) TYLER NIELSEN - LA667067

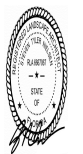

01.25.2024

IRRIGATION DETAILS

DATE	ISSUE
05.17.2023	25% CD
06.21.2023	50% CD
07.19.2023	75% CD
01.25.2024	75% CD

L801

DESIGNED BY NIELSEN LANDSCAPE ARCHITECTS, LLC

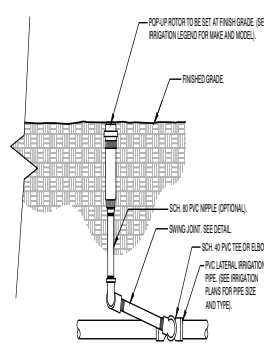
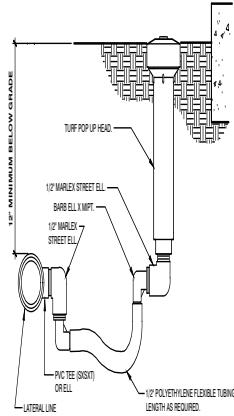

NOTES:
 1- ALL THREADED CONNECTION POINTS BETWEEN SCH 40 PVC AND SCH 80 PVC FITTINGS SHALL BE INSTALLED USING TEFLOW TAPE.
 2- CONTRACTOR SHALL COMPACT SOIL AROUND ROTOR AND RISER PRIOR TO PLANTING, PLUGGING, SEEDING, OR LAYING OF SOG.

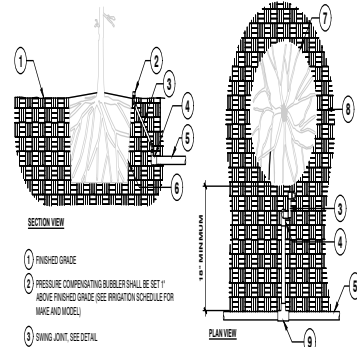

SECTION VIEW

- 1 FINISHED GRADE
- 2 PRESSURE COMPENSATING BUBBLER SHALL BE SET 1\"/>
- 3 SWING JOINT, SEE DETAIL
- 4 SCH 40 PVC BY ELBOW SLIP TO THREAD
- 5 LATERAL LINE IRRIGATION, (SEE IRRIGATION PLANS FOR SIZING)
- 6 EDGE OF ROOT BALL, SETTLE BACKFILL SO IRRIGATION FLOWS THROUGH ROOT BALL
- 7 EDGE OF ROOT BALL
- 8 EXISTING OR MODIFIED SOIL, (SEE SPECIFICATIONS FOR SOIL MODIFICATION)
- 9 SCH 40 PVC TEE OR BY ELBOW

NOTES:
 1. ALL IRRIGATION FITTINGS SHALL BE SCH 40 PVC UNLESS SPECIFIED OTHERWISE.
 2. ALL THREADED CONNECTIONS FROM SCH 40 TO SCH 80 PVC SHALL BE MADE USING TEFLOW TAPE.
 3. CONTRACTOR SHALL SETTLE THE AREA AROUND THE BUBBLER AND EDGE OF THE ROOT BALL SO THAT ALL IRRIGATION FLOWS THROUGH THE ROOT BALL.



1447 Cypress Drive, 2
 Jupiter, FL 33469
 561.402.9414

www.nielsenlandscape.com

1 TURF SPRAY FLEX ASSEMBLY
 3\"/>

2 ROTOR SPRAYHEAD
 1 1/2\"/>

3 IRRIGATION BUBBLER W/ LAYOUT
 3/4\"/>

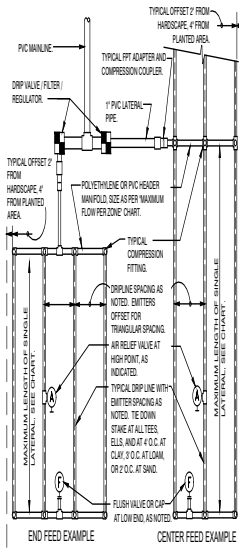

MAXIMUM LATERAL LENGTH (FEET)			
PSI	EMITTER FLOW RATE (GPH)		
	12\"/>		
10	125 @ 0.6	175 @ 0.9	218 @ 0.9
20	248 @ 0.6	350 @ 0.9	442 @ 0.9
30	307 @ 0.6	434 @ 0.9	530 @ 0.9
40	352 @ 0.6	495 @ 0.9	607 @ 0.9
50	385 @ 0.6	535 @ 0.9	658 @ 0.9
60	408 @ 0.6	565 @ 0.9	698 @ 0.9

GRID PRECIPITATION RATES (IN/HR)			MAXIMUM FLOW PER ZONE	
EMITTER SPACING	LATERAL SPACING	EMITTER FLOW RATE	MAX GPM	PSI LOSS
12\"/>				

LATERAL FLOW PER 100 FT (GPM)			
EMITTER FLOW	POLY PIPE HEADER SIZE		
	12\"/>		
0.6 GPM	1.0 GPM	1.67 GPM	4.0 GPM
0.9 GPM	1.5 GPM	2.5 GPM	6.0 GPM

SLOPED CONDITION NOTE:
 1. DRIPLINE LATERALS SHOULD FOLLOW THE CONTOURS OF THE SLOPE.
 2. INSTALL AIR RELIEF VALVE AT HIGHEST POINT.
 3. NORMAL SPACING WITHIN THE TOP 1/3 OF SLOPE.
 4. INSTALL DRIPLINE AT EVEN GREATER SPACING AT THE BOTTOM 1/3 OF THE SLOPE.
 5. WHEN THE ELEVATION CHANGE IS 1 FT OR MORE, ZONE THE BOTTOM 1/3 ON A SEPARATE VALVE.

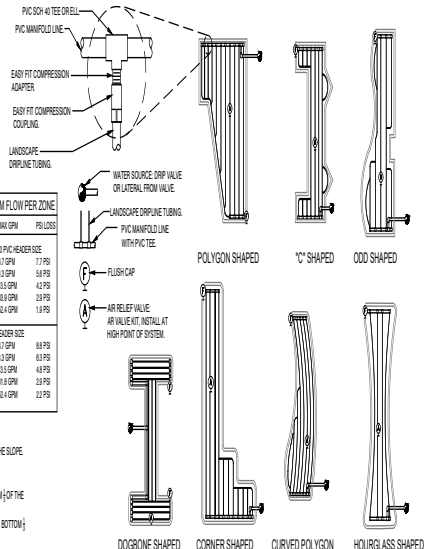

4 TYPICAL DRIPLINE REQUIREMENTS
 N.T.S.

LOT 10 GARDEN
 1120 BAY DRIVE | MIAMI BEACH, FLORIDA 33141

SEAL IS TYLER NIELSEN - LA667007

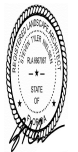

01.25.2024

IRRIGATION DETAILS	
DATE	ISSUE
05.17.2023	55% CD
06.21.2023	50% CD
07.19.2023	75% CD
01.25.2024	75% CD



L802

DESIGN BY NIELSEN LANDSCAPE ARCHITECTS

BACKFLOW PREVENTER
IRRIGATION INSTALLER TO FOLLOW LOCAL CODES. VERIFY LOCATION IN THE FIELD BEFORE INSTALLATION. SEE THE PRODUCT LEGEND FOR THE BACKFLOW MANUFACTURER AND MODEL #.

IRRIGATION WATER POINT OF CONNECTION
INSTALL A 1" IRRIGATION WATER METER IN THIS AREA. THE WATER METER IS TO SUPPLY A MINIMUM OF 300GPM AT 60PSI FOR THE EFFICIENT OPERATION OF THIS SYSTEM. VERIFY LOCATION IN THE FIELD PRIOR TO INSTALLATION. THE IRRIGATION CONTRACTOR IS TO NOTIFY THE LANDSCAPE ARCHITECT PRIOR TO CONSTRUCTION IF THE REQUIRED PRESSURE IS NOT AVAILABLE ON THE DOMESTIC WATER LINE.

IRRIGATION CONTROLLER
TO BE MOUNTED ON THE EXTERIOR WALL OF THE BUILDING IN THIS AREA. SEE DETAIL. VERIFY MOUNT LOCATIONS IN THE FIELD PRIOR TO INSTALLATION. 120VAC, 1.0 AMP. ELECTRIC POWER SUPPLY PROVIDED BY THE BUILDING ELECTRICAL CONTRACTOR. ROUTE A 1.5" ELECTRICAL CONDUIT WITH CONTROL WIRES FROM THE CONTROLLER TO THE MAINLINE TRENCH. MOUNT THE RAIN SENSOR ON A STATIONARY STRUCTURE ABOVE ALL OVERHEAD OBSTRUCTIONS. PROVIDE TWO (2) ADDITIONAL CONTROL WIRES IN WIRE BUNDLE FOR FUTURE USE.

THE IRRIGATION CONTRACTOR IS TO SET THE RUN TIMES FOR EACH ZONE TO MATCH THE PLANT WATER REQUIREMENTS, SITE CONDITIONS AND MICRO-CLIMATE FACTORS. SEE THE LANDSCAPE PLANS FOR PLANT SPECIFICATIONS.

COORDINATE THE LATERAL LINE PENETRATION POINTS INTO EACH BASED PLANTER WITH THE HARDSCAPE CONTRACTOR PRIOR TO CONSTRUCTION

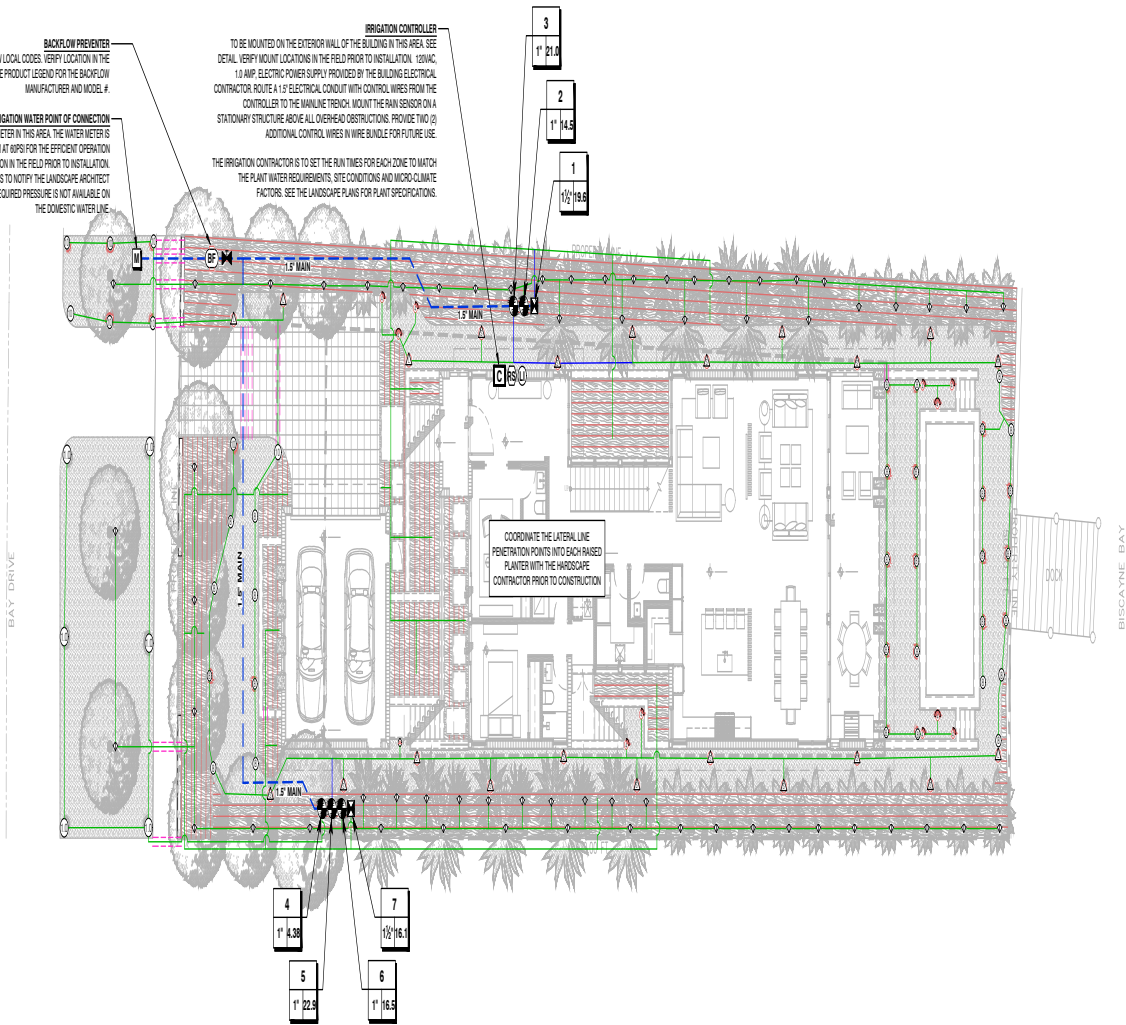

NIELSEN
landscape architects
1447 cypress drive, 2
jupiter, fl 33489
561.402.9414
www.nielсенlandarch.com

LOT B GARDEN
1350 BAY DRIVE | MIAMI BEACH, FLORIDA 33141

SEAL: TYLER NIELSEN - LA667007

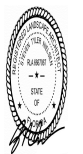

01.25.2024

IRRIGATION PLAN

DATE	ISSUE
05.17.2023	55% CD
06.21.2023	50% CD
07.19.2023	75% CD
01.25.2024	75% CD

LATERAL LEGEND	
—	1"
—	1.5"
—	2"
—	2.5"

SLEEVE LEGEND	
LATERAL/MAINLINE SIZE	SLEEVE SIZE
1"	2"
1.5"	3"
2"	4"
2.5"	4"
3"	6"
4"	8"
CONTROL WIRE CONDUIT	2"

SLEEVES ARE

INSTALL ALL THE IRRIGATION EQUIPMENT TO AVOID CONFLICTS WITH INSTALLED UTILITIES & TREE INSTALLATION. THE IRRIGATION MAINLINE, LATERAL LINE, AND IRRIGATION SPRINKLER LOCATIONS ARE SHOWN SCHEMATICALLY AND SHALL BE ADJUSTED BASED ON FIELD CONDITIONS. ALL LANDSCAPED AREAS ARE TO RECEIVE 100% COVERAGE BY THE IRRIGATION SYSTEM (TYP).



L803

©2024 NIELSEN LANDSCAPE ARCHITECTS, LLC