

Sophia Chesrow

From: Espinales Montoya, Moises <MoisesEspinales@miamibeachfl.gov>
Sent: Monday, April 28, 2025 5:16 PM
To: Joe Vecchione; PERMIT X INC
Cc: Sophia Chesrow; Duncan Bath - Architectural Project Manager Cactus Club
Subject: RE: BC2525225 - 850 Commerce St

Good afternoon Joe,

Thank you for your patience and for send me the diagrams. I have no objection to the seating adjustments. As a result of this exercised, a CUP will no longer be required. Please update the plans accordingly.

I spoke with the Chief of Planning Services after discovering a "fee in lieu of parking" statement associated with the building. According to the city's land development regulations, one parking space is required for every four seats. With the newly proposed plans increasing the seat count to 228, a total of 57 parking spaces would be required. The location currently has a credit for 32 spaces, resulting in a difference of 25 spaces that will need to be provided.

When alteration or rehabilitation of a structure results in an increased parking requirement, the fee in lieu of providing parking shall be satisfied by one of the following options.

1. A one-time payment of \$40,000.00 per parking spaces.
2. A yearly payment of \$800.00 per parking spaces, which shall continue as long as the use exists. The amount of such payment may vary from year to year in accordance with the determination set forth in subsection d.

For those projects which are eligible for and elect a yearly payment plan, the first fee-in-lieu payment shall be [due] at the issuance of certificate of use. The amount due shall be prorated from September 30. Subsequent annual payments shall be paid in full by June 1 as long as the use exists.

Upon acknowledgement, If you decide to proceed, an account will be created to continue the payments. Let me know if you have any questions or would like to coordinate a meeting.

Respectfully,



Moises Espinales

Senior Zoning Plans Examiner

Planning Department

1700 Convention Center Drive – 2nd Floor, Miami Beach, FL 33139

Tel: 305-673-7000 x 26877 / www.miamibeachfl.gov

It's easy being Green! Please consider our environment before printing this email.

We are committed to providing excellent public service and safety to all who live, work and play in our vibrant, tropical, historic community.

From: Joe Vecchione <jvecchione@bergmeyer.com>

Sent: Tuesday, April 22, 2025 2:00 PM

To: Espinales Montoya, Moises <MoisesEspinales@miamibeachfl.gov>; PERMIT X INC <mpermx2@gmail.com>

Cc: Sophia Chesrow <schesrow@bergmeyer.com>; Duncan Bath - Architectural Project Manager Cactus Club <duncanbath@cactusclubcafe.com>

Subject: RE: BC2525225 - 850 Commerce St

[THIS MESSAGE COMES FROM AN EXTERNAL EMAIL - USE CAUTION WHEN REPLYING AND OPENING LINKS OR ATTACHMENTS]

Hi Moises –

Hope you had a good weekend!

Thanks for the response. As we revised our seat enumerated plan based on actual seats (including exterior seating), our total seat count is 228. In addition to that, we will have 42 employees bringing the total actual load to 270. Even if we added 1 occupant per 7 sf to account for standing room around the bar to satisfy Life Safety comments, we'd be capped at 293 occupants. Both calculations would be under the 300 occupants that would trigger a CUP review by Planning Board, which, for overall schedule and progression of permitting process, we are trying to stay below the threshold.

For the purpose of Planning, the deciding factor of whether or not we need to go for CUP is whether we are permitted to individually label each seat (hence providing an amended G001.2 Enumerated Seating Plan as previously requested by Planning) or if we need to calculate the banquettes for Planning review purposes at 1 person per 18" which, especially at round and semi-circular banquettes as there would be no knee room for the patrons, as that puts us well over 300 occupants which will never be the case in this restaurant. For reference, I am including below a series of diagrams illustrating the different banquette conditions we have with plan people for scale purposes which I hope are helpful:

If calculating at 18" per occupant, a booth that realistically can seat 4 patrons is required to seat 8:

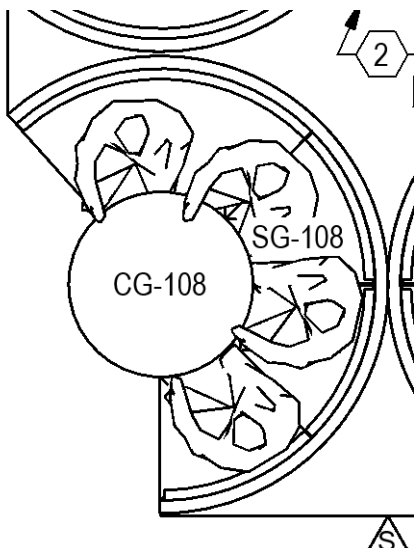

If calculating at 18" per occupant, a booth that realistically can seat 5 patrons is required to seat 9:

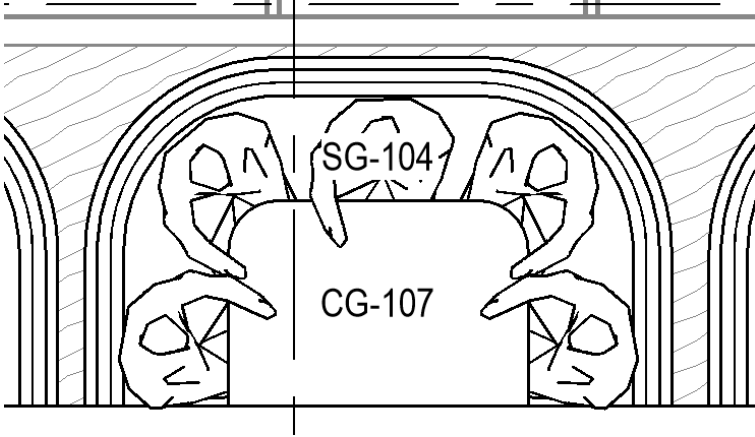

If calculating at 18" per occupant, a booth that realistically can seat 6 patrons is required to seat 11:

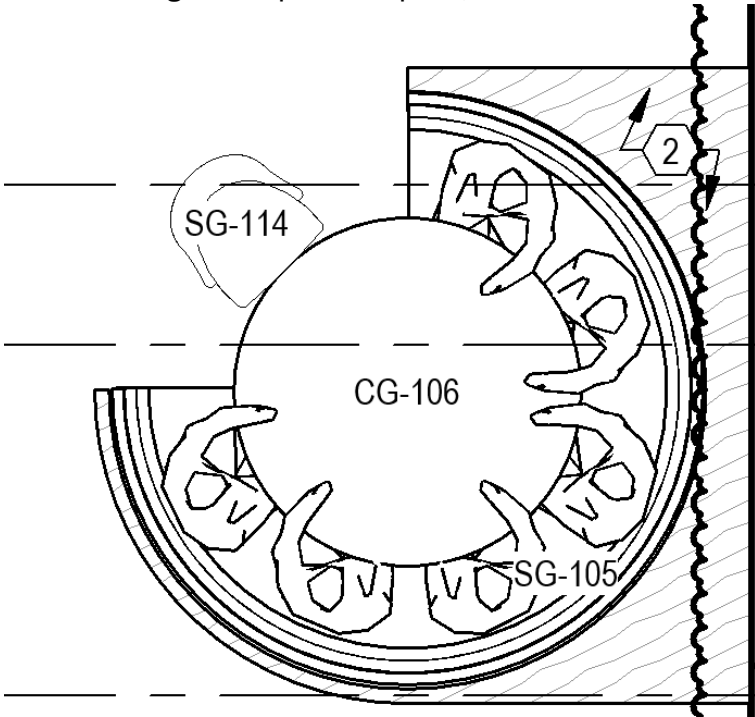

If calculating at 18" per occupant, a bench with 4 tables that realistically can seat 4 patrons adjacent is required to seat 15. For illustrative purposes, I tried to squeeze as many occupants hip to hip on that bench as possible and could only fit 12 people, many of which would not have adequate dining surface for their meals nor be able to leave their seats if the banquette is full:

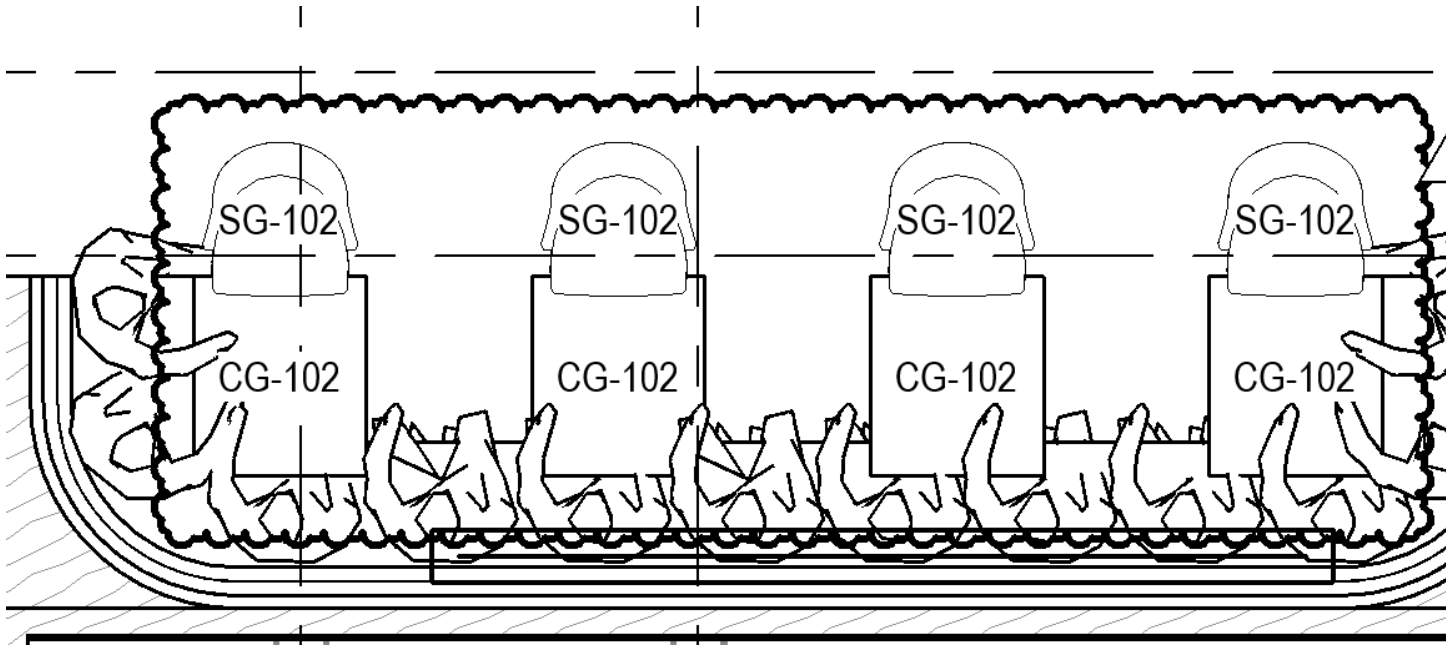

We hope that these illustrations will be helpful as you continue the review of this project, and we are more than happy to provide any additional information or context to assist you in your review. Please let us know your thoughts.

Joe Vecchione, AIA

Associate, Senior Architect

Bergmeyer

Boston | Columbus | Los Angeles

51 Sleeper Street | 6th Floor
Boston, MA 02210

617.542.1025 office
781.520.9859 mobile

www.bergmeyer.com

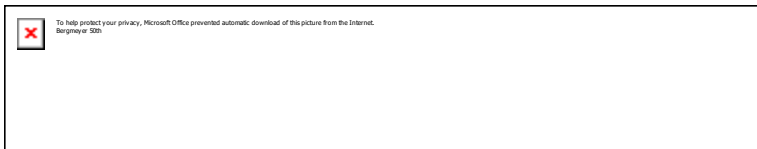

From: Espinales Montoya, Moises <MoisesEspinales@miamibeachfl.gov>

Sent: Tuesday, April 22, 2025 10:02 AM

To: Joe Vecchione <jvecchione@bergmeyer.com>; PERMIT X INC <mpermx2@gmail.com>

Cc: Sophia Chesrow <schesrow@bergmeyer.com>; Duncan Bath - Architectural Project Manager Cactus Club <duncanbath@cactusclubcafe.com>

Subject: RE: BC2525225 - 850 Commerce St

Good morning Joe,

Yes, I was able to confirm that the CUP content of 300 people is based on the design's occupant load (which includes the front outside area). I was able to confirm with a member of DRB.

I'm going to investigate this project a bit further. BTR submitted expired in 2024 but Planning records show that the business that had a Fee in Lieu but the last inspection in 2015 showed that the business was vacant.

Respectfully,



Moises Espinales

Senior Zoning Plans Examiner

Planning Department

1700 Convention Center Drive – 2nd Floor, Miami Beach, FL 33139

Tel: 305-673-7000 x 26877 / www.miamibeachfl.gov

It's easy being Green! Please consider our environment before printing this email.

We are committed to providing excellent public service and safety to all who live, work and play in our vibrant, tropical, historic community.

From: Joe Vecchione <jvecchione@bergmeyer.com>

Sent: Friday, April 18, 2025 11:15 AM

To: Espinales Montoya, Moises <MoisesEspinales@miamibeachfl.gov>; PERMIT X INC <mpermx2@gmail.com>

Cc: Sophia Chesrow <schesrow@bergmeyer.com>; Duncan Bath - Architectural Project Manager Cactus Club <duncanbath@cactusclubcafe.com>

Subject: RE: BC2525225 - 850 Commerce St

[THIS MESSAGE COMES FROM AN EXTERNAL EMAIL - USE CAUTION WHEN REPLYING AND OPENING LINKS OR ATTACHMENTS]

Good morning, Moises –

Thank you again for your time yesterday to review the open planning items for 850 Commerce Street. We appreciate your insight into these issues and how to best address these comments.

Thank you for reviewing the duct cover detail and approving it administratively. We will reference our correspondence when we formally respond back to the comments from plan review.

In regard to the CUP, can you confirm if the 300 trigger for this review encompasses total occupant load (seating + employees) or total seat count (as indicated on G001.2)? Also, as discussed, can we utilize actual seat count as discussed for banquette seating (i.e. 1 seat per corresponding table, front of banquette for round booth seating) given Cactus will not be seating anywhere close to the 1 occupant per 18” banquette length life safety is asking for. Cactus is also happy to provide an affidavit to put this condition in writing how many occupants they seat in each booth from an operational perspective. For example, we have 1 banquette which has 5 tables and 5 loose seats on the opposite side. Calculating this banquette at 1 occupant per 18” results in 13 seats whereas, realistically, there would be 5 patrons in that banquette. If we are able to use the metrics discussed which reflect the realistic number of patrons being served, we would likely dip below 300 here.

Lastly, can you confirm if the mobility fee for number of seats applies only if we need to go for the CUP or is a standard fee outside of the Planning Board process.

Thanks again for your time!

Joe Vecchione, AIA

Associate, Senior Architect

Bergmeyer

Boston | Columbus | Los Angeles

51 Sleeper Street | 6th Floor

Boston, MA 02210

617.542.1025 office

781.520.9859 mobile

www.bergmeyer.com



From: Espinales Montoya, Moises <MoisesEspinales@miamibeachfl.gov>

Sent: Thursday, April 17, 2025 3:17 PM

To: PERMIT X INC <mpermx2@gmail.com>

Cc: Joe Vecchione <jvecchione@bergmeyer.com>; Sophia Chesrow <schesrow@bergmeyer.com>; Duncan Bath - Architectural Project Manager Cactus Club <duncanbath@cactusclubcafe.com>

Subject: RE: BC2525225 - 850 Commerce St

Good afternoon everyone,

I was a pleasure meeting with you all this morning.

For this particular design, I was able to confirm that with the Development & Resiliency Officer that the duct and duct cover can be approved administratively at its current location.

Please also note that the CUP content of 300 people is based on the design's occupant load. The current proposed total of 395 exceeds this number. I understand that reducing the occupant count by nearly 100 seats presents a challenge. If design modifications are unable to bring the count down to 299 or fewer, you will need to coordinate a pre-application meeting with Michael Belush (michaelbelush@miamibeachfl.gov).

Lastly, I'd like to mention—since it was not discussed during the meeting—that a mobility fee of \$1,124.59 per seat will apply, in addition to a \$515.00 administrative fee. A credit will be applied for the existing 172 seats.

Please don't hesitate to reach out if you have any further questions.

Kindly,



Moises Espinales

Senior Zoning Plans Examiner

Planning Department

1700 Convention Center Drive – 2nd Floor, Miami Beach, FL 33139

Tel: 305-673-7000 x 26877 / www.miamibeachfl.gov

It's easy being Green! Please consider our environment before printing this email.

We are committed to providing excellent public service and safety to all who live, work and play in our vibrant, tropical, historic community.

From: PERMIT X INC <mpermx2@gmail.com>

Sent: Tuesday, April 15, 2025 4:11 PM

To: Espinales Montoya, Moises <MoisesEspinales@miamibeachfl.gov>

Cc: Joe Vecchione <jvecchione@bergmeyer.com>; Sophia Chesrow <schesrow@bergmeyer.com>; Duncan Bath - Architectural Project Manager Cactus Club <duncanbath@cactusclubcafe.com>

Subject: BC2525225 - 850 Commerce St

[THIS MESSAGE COMES FROM AN EXTERNAL EMAIL - USE CAUTION WHEN REPLYING AND OPENING LINKS OR ATTACHMENTS]

Good afternoon Moises,

Please advise if you are available for a meeting this week to go over some comments on this process - **BC2525225**?

I have added the comments below. Please advise and reply all, the architect is in copy.

Comment #12 - Upon review of the new documents, the proposed duct and cover are too close to the storefront and cannot be approved administratively. Please setback duck work and cover 10 minimum from storefront.

Comment #13 - Additionally, an establishment determined to be a Neighborhood Impact Establishment would require Planning Board Approval for a conditional use. Neighborhood impact establishment means: (1) An alcoholic beverage establishment or restaurant, not also operating as an entertainment establishment or dance hall (as defined in section 114-1), with an occupant content of 300 or more persons as determined by the chief fire marshal.

Thank you,
Helen Calveiro
305-710-1118
mpermx@aol.com | mpermx@gmail.com