



1600 Washington

Miami Beach, Florida 33140

prepared for:

Beilingson Gomez Architects

traffic study

TRAFTECH
ENGINEERING, INC.

July 2025

ENGINEER'S CERTIFICATION

I, Hereby certify that I am a registered professional engineer in the State of Florida, practicing with Traf Tech Engineering, Inc., a Florida Corporation under Section 471.023, Florida Statutes, to offer engineering services to the public through a Professional Engineer, duly licensed under Chapter 471, Florida Statutes, Professional License Number 44174, by the State of Florida, Department of Professional Regulation, Board of Professional Engineers, and that I have prepared or approved the evaluation, findings, opinions, conclusions, or technical advice hereby reported for:

Project: 1600 Washington
Location: Miami Beach, Florida
Client: Beilingson Gomez Architects

Report Prepared by: Traf Tech Engineering, Inc
8400 N. University Drive, Suite 309
Tamarac, FL 33321

I acknowledge that the procedures and references used to develop the results contained in this report are standards to the professional practice of transportation engineering as applied through professional judgement and experience.

Signature:
Name:
License No.
Date:

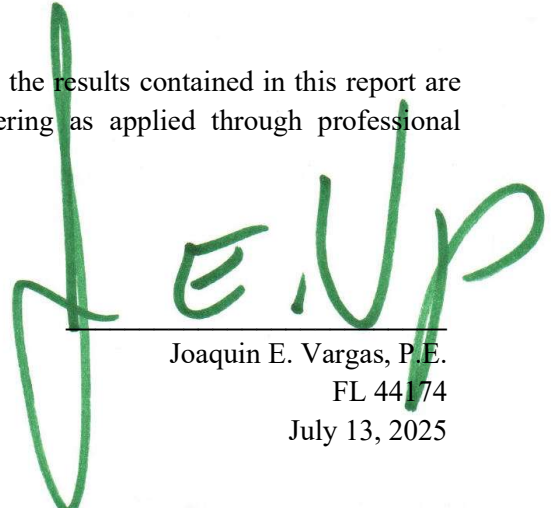

Joaquin E. Vargas, P.E.
FL 44174
July 13, 2025



TABLE OF CONTENTS

INTRODUCTION	1
INVENTORY	3
Existing Land Use.....	3
Proposed Land Uses and Access.....	3
EXISTING CONDITIONS	4
Roadway System.....	4
Nearby Intersections	4
TRAFFIC COUNTS	6
TRIP GENERATION	8
TRIP DISTRIBUTION AND TRAFFIC ASSIGNMENT	9
TRAFFIC ANALYSES	11
Future Conditions Traffic Volumes	11
Level of Service Analyses	15
Parking.....	18
Maneuverability Analyses	18
Queuing and Valet Service	18
TDM	18
CONCLUSIONS AND RECOMMENDATIONS	21

LIST OF FIGURES

FIGURE 1 – Project Location Map	2
FIGURE 2 – Existing Lane Geometry.....	5
FIGURE 3 – Existing Traffic Counts – Peak Hour	7
FIGURE 4 – New Project Traffic Assignment (New Trips)	10
FIGURE 5 – Background Traffic (Year 2028).....	13
FIGURE 6 – Total Traffic with Project (Year 2028).....	14

LIST OF TABLES

TABLE 1 – Weekday Trip Generation – Existing Site	8
TABLE 2 – Weekday Trip Generation – Proposed.....	8
TABLE 3– Project Trip Distribution	9
TABLE 4A – Signalized Intersection Capacity/LOS Analyses AM Peak	16
TABLE 4B – Signalized Intersection Capacity/LOS Analyses PM Peak	16

Appendices

Appendix A –Traffic Methodology

Appendix B – Site Plan

Appendix C –Traffic Counts and Signal Timing Plans

Appendix D – Peak Season Conversion Factor, Historical Traffic Data, Growth Analysis, and Committed Developments

Appendix E – Future Turning Movement Volumes

Appendix F – Synchro

INTRODUCTION

1600 Washington is a proposed mixed-use development planned to be located at 1600 Washington Avenue in the City of Miami Beach in Miami-Dade County, Florida. The location of the project site is illustrated in Figure 1 on the following page.

Traf Tech Engineering, Inc. was retained to conduct a traffic study¹ in connection with the proposed development. The study addresses trip generation and the traffic impacts created by the proposed project on the nearby transportation network. This study is divided into seven (7) sections, as listed below:

1. Inventory
2. Existing Conditions
3. Traffic Counts
4. Trip Generation
5. Trip Distribution and Traffic Assignment
6. Traffic Impact Analysis
7. Conclusions and Recommendations

¹ The traffic methodology was discussed and agreed with the City of Miami Beach staff and is presented in Appendix A.

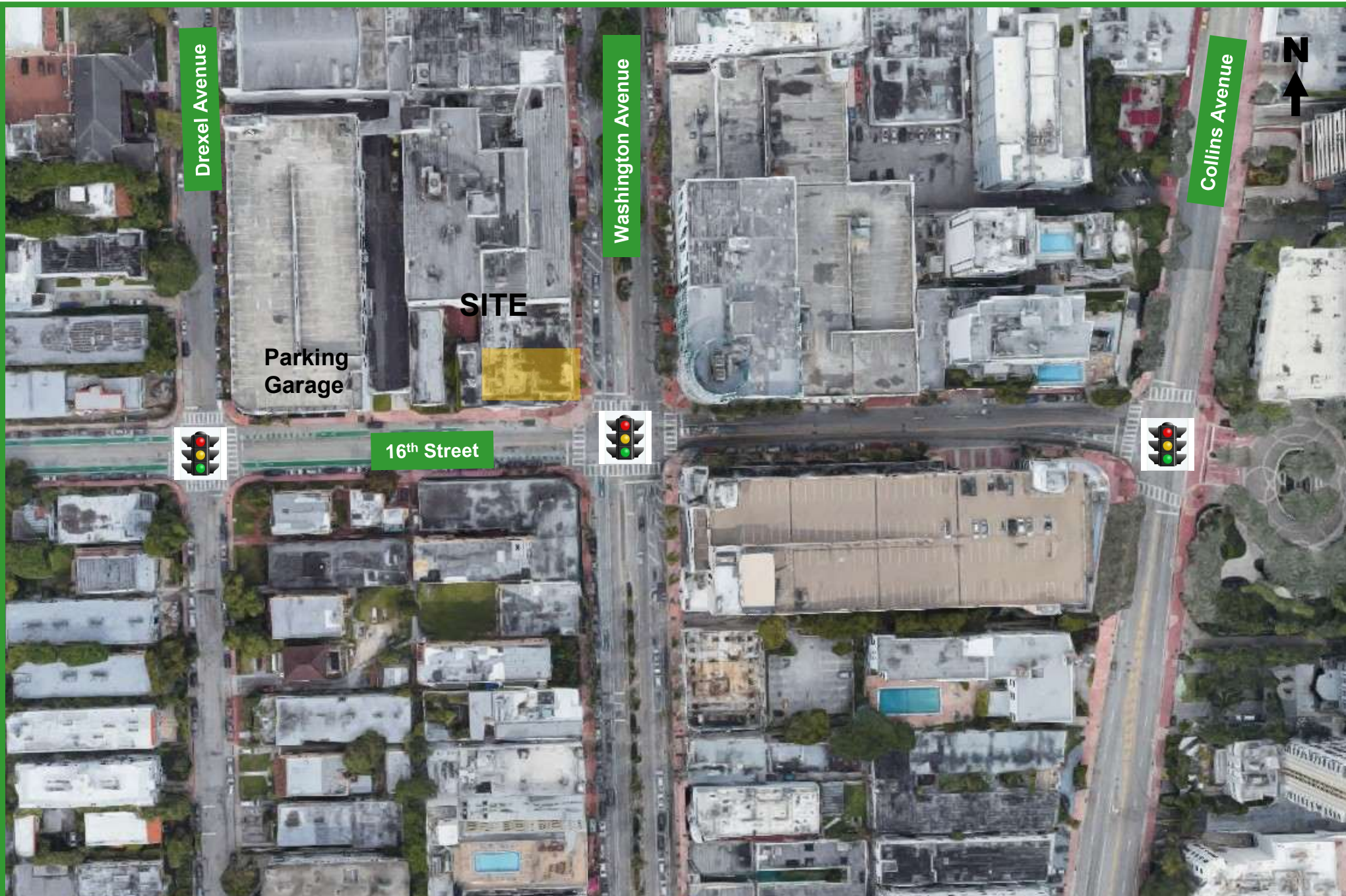

INVENTORY

Existing Land Use

The project site is currently developed with commercial uses (approximately 9,810 square feet). This site was previously approved with residential/retail uses generating approximately 796 daily trips and approximately 81 PM peak hour trips.

Proposed Land Uses and Access

The proposed project consists of the following land uses and intensities:

- 210 high-rise residential units
- 6,900 square feet of retail

The proposed development is anticipated to be built and occupied in 2028. Appendix B contains a copy of the proposed site plan for the project site.

EXISTING CONDITIONS

This section addresses the existing roadway system located in the vicinity of the project site and nearby intersections.

Roadway System

The roadway system located near the project site includes Drexel Avenue, Washington Avenue, Collins Avenue, and 16 Street. Drexel and Washington Avenues are both two-lane north-south facilities. Collins Avenue is a four-lane north-south facility and 16th Street is two-lane east-west local facility.

Nearby Intersections



With the assistance of City of Miami Beach staff, four intersections were identified as the locations that will be impacted the most by the proposed project. These intersections include:

1. 16th Street and Drexel Avenue (signalized)
2. 16th Street and Parking Garage Entrance (unsignalized)
3. 16th Street and Washington Avenue (signalized)
4. 16th Street and Collins Avenue (signalized)

Figure 2 shows the existing lane geometry of the study intersections selected for analysis purposes.



LEGEND

-  Left-Turn Lane
-  Through Lane
-  Right-Turn Lane

TRAFFIC COUNTS

Traf Tech Engineering, Inc., collected intersection turning movement counts at the four study intersections. The intersection turning movement counts were collected on Thursday, June 12, 2025 from 7:00 AM and 9:00 AM and from 4:00 PM and 6:00 PM at the following four intersections located near the project site:

1. 16th Street and Drexel Avenue (signalized)
2. 16th Street and Parking Garage Entrance (unsignalized)
3. 16th Street and Washington Avenue (signalized)
4. 16th Street and Collins Avenue (signalized)

Appendix C contains the intersection turning movement counts, as collected in the field. The latest signal timing plans for the signalized intersections were obtained from Miami-Dade County Traffic Engineering Division and are also included in Appendix C. The traffic counts were adjusted by utilizing a peak season factor based on FDOT peak season adjustment factors. The State-published adjustment factors are contained in Appendix C.

Figure 3 shows the 2025 peak season AM and PM peak hour traffic volumes.

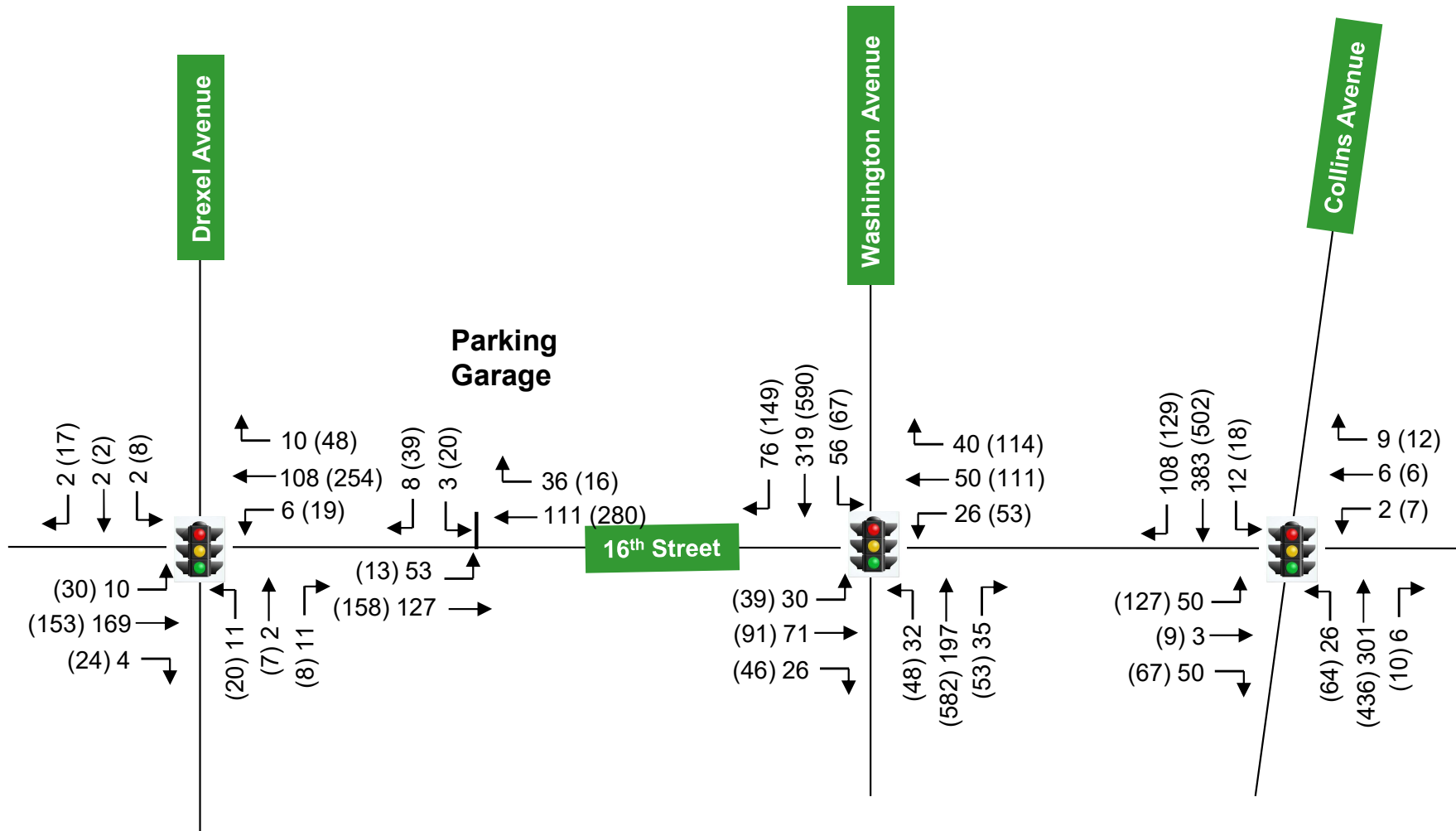

LEGEND	
XX	AM Peak Hour
(YY)	PM Peak Hour

TRIP GENERATION

The trip generation for the project was based on information contained in the Institute of Transportation Engineer’s (ITE) *Trip Generation Manual*¹ (11th Edition). According to the subject ITE manual, the most appropriate “land use” categories for existing and proposed land uses include ITE’s Land Use 822 – Retail < 40k and ITE’s Land Use 222 – Residential High-Rise. Tables 1 and 2 summarize the existing and proposed trips associated with the proposed development.

TABLE 1 Trip Generation Summary (Existing at Site) 1600 Washington								
Land Use	Size	Daily Trips	AM Peak Hour			PM Peak Hour		
			Total Trips	Inbound	Outbound	Total Trips	Inbound	Outbound
Retail <40k (LUC 822)	9,810 sf	644	28	17	11	77	39	38
Gross/Driveway Trips		644	28	17	11	77	39	38
Pass-by (25%) - PM Only		-161	0	0	0	-20	-10	-10
External Trips		483	28	17	11	57	29	28

Source: ITE Trip Generation Manual (11th Edition)
NOTE: ITE Has no pass-by data for LUC 822, used 25%

TABLE 2 Trip Generation Summary (Proposed) 1600 Washington								
Land Use	Size	Daily Trips	AM Peak Hour			PM Peak Hour		
			Total Trips	Inbound	Outbound	Total Trips	Inbound	Outbound
Residential High-Rise (LUC 222)	210 units	1,167	65	22	43	78	44	34
Retail <40k (LUC 822)	6,900 sf	521	23	14	9	60	30	30
Gross Trips		1,688	88	36	52	138	74	64
Internal Trips		-269	0	0	0	-22	-11	-11
Driveway Trips		1,419	88	36	52	116	63	53
Pass-by (25%) - PM Only		-159	0	0	0	-13	-7	-6
External Trips		1,260	88	36	52	103	56	47

Source: ITE Trip Generation Manual (11th Edition)
NOTE: ITE Has no pass-by data for LUC 822, used 25%

Difference (Proposed - Existing)	Daily	AM Peak Hour			PM Peak Hour		
	Trips	Total Trips	Inbound	Outbound	Total Trips	Inbound	Outbound
Driveway Trips	775	60	19	41	39	24	15
External Trips	777	60	19	41	46	27	19

TRIP GENERATION MANUAL 11TH EDITION

ITE Land Use Code 222 - Multifamily High-Rise)

Daily Trips: $T = 3.76 (X) + 377.04$, X = number of units
 AM Peak: $T = 0.22 (X) + 18.85$ (34% inbound and 66% outbound), X = number of units
 PM Peak: $T = 0.26 (X) + 23.12$ (56% inbound and 44% outbound), X = number of units

ITE Land Use Code 822 Retail (<40k)

Daily Trips: $T = 42.20 (X) + 229.68$, X = 1,000 square feet
 AM Peak: $\ln (T) = 0.66 \ln (X) + 1.84$ (60% inbound and 40% outbound), X = 1,000 square feet
 PM Peak: $\ln (T) = 0.71 \ln (X) + 2.72$ (50% inbound and 50% outbound), X = 1,000 square feet

As indicated at the end of Table 2, the external new trips anticipated to be generated by the proposed development during the AM peak hour includes approximately 60 peak-hour trips (19 inbound and 41 outbound) and during the PM peak hour includes approximately 46 trips (27 inbound and 19 outbound).

TRIP DISTRIBUTION AND TRAFFIC ASSIGNMENT

The trip distribution and traffic assignment for the project were based on Miami-Dade County's Cardinal Distribution information for the study area. Table 3 summarizes the County's cardinal distribution data for Traffic Analysis Zone 643, which is applicable to the project site from the latest SERPM data published by Miami-Dade County.

TABLE 3								
Project Trip Distribution								
TAZ # 643								
Year	Movement							
	NNE	ENE	ESE	SSE	SSW	WSW	WNW	NNW
2015	18.20%	5.70%	0.00%	10.10%	5.00%	27.00%	16.20%	17.90%
2045	15.30%	4.70%	0.00%	9.20%	5.10%	30.50%	17.70%	17.50%
2028*	16.94%	5.27%	0.00%	9.71%	5.04%	28.52%	16.85%	17.73%

*Note: * Interpolated Values*

Source: Miami-Dade County (2045 SERPM)

Based on the above, the following traffic assignment was assumed for the proposed development:

- 28% to and from the north via Collins Avenue
- 15% to and from the south via Collins Avenue
- 25% to and from the north via Washington Avenue
- 22% to and from the south via Washington Avenue
- 2% to and from the north via Drexel Avenue
- 3% to and from the south via Drexel Avenue
- 5% to and from the west via 16th Street

The new peak hour traffic generated by the project was assigned to the nearby transportation network using the traffic assignment documented above. The new project traffic assignment is summarized in Figure 4.

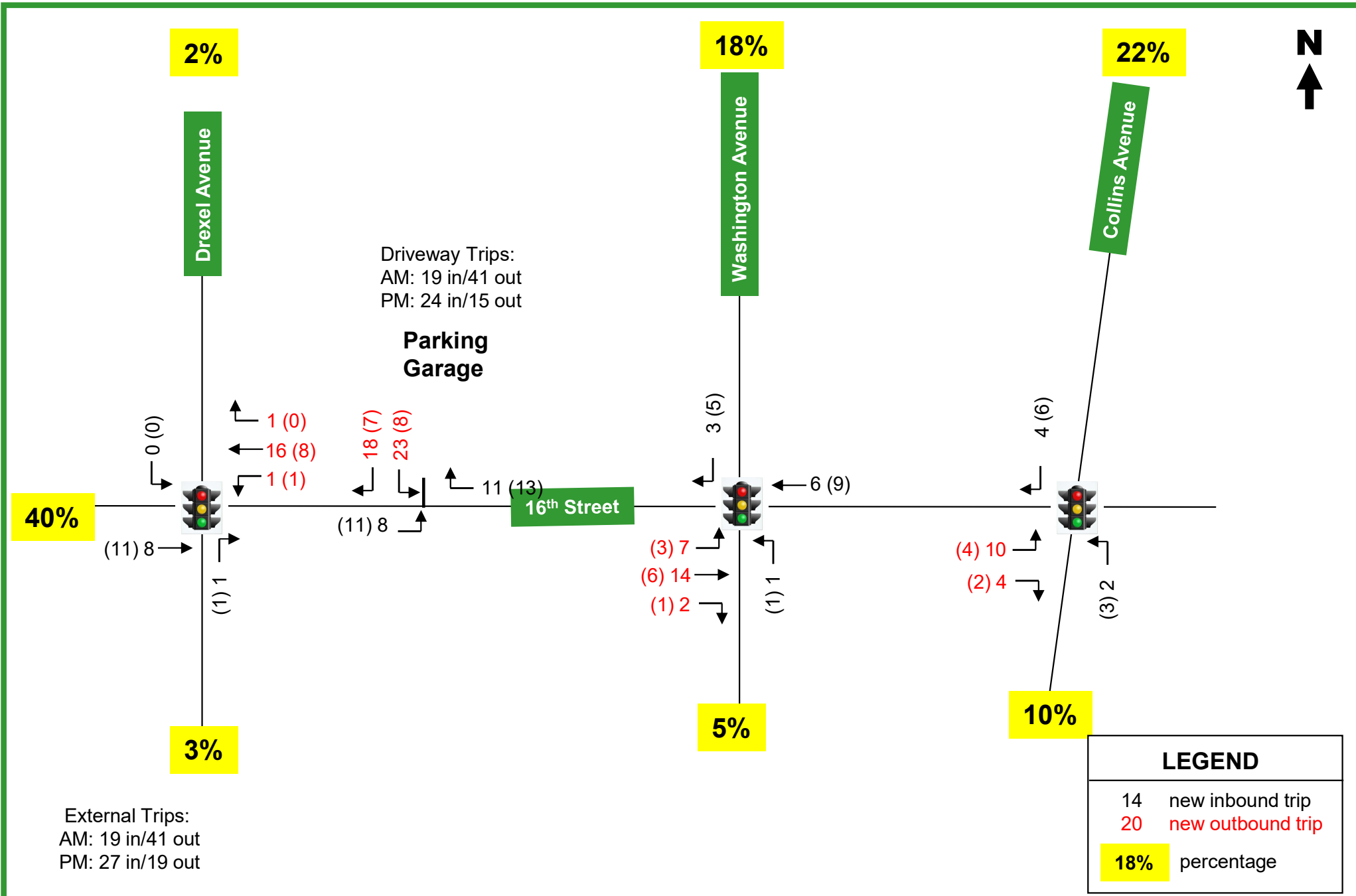

TRAFFIC ANALYSIS

This section of the study includes six (6) parts. The first part consists of developing the future conditions traffic volumes for the study area. The second part includes level-of-service analyses for existing and future conditions. The last four sections address parking, maneuverability analysis, queuing and valet services, and transportation demand management.

Future Conditions Traffic Volumes

Two sets of future traffic volumes were developed. The first set includes project buildout conditions without the proposed project and the second set adds the new trips anticipated to be generated by the project.

In order to develop year 2028 traffic volumes (project anticipated to be built and occupied by the year 2028), without the proposed project, two separate analyses were undertaken. The first analysis converts the existing peak hour traffic counts collected in the field to average peak season conditions. Based on FDOT's Peak Season Factor Category report, a factor of 1.12 is required to convert traffic counts to average peak season conditions (refer to Appendix D). The second analysis includes a growth factor to project 2025 peak season traffic volumes to the year 2028. Based on traffic growth data published by the FDOT for a nearby traffic count stations, traffic growth has not occurred during the past five and ten years (refer to Appendix D). The historical growth analysis was compared to 2015 and 2045 FSUTMS SERPM volume growth in order to select a conservative growth rate for the project. A 1.0% growth rate was used for purposes of this study.

Traffic associated with committed developments: 1620 Drexel, 1501 Washington, Lincoln Road 200-300 Block - James Avenue Traffic Diversions, Lincoln Road 200-300 Block – Lincoln Road Traffic Diversions, and Lincoln Road 100 Block were added to peak season volumes in order to develop 2028 background traffic conditions for the area.

The future traffic projections for the study intersections (peak season adjustments, and growth rate) are presented in tabular format in Appendix E. Figures 5 and 6 present the year 2028 future traffic volumes for the study area. Figure 5 includes background traffic only (without the proposed project) and Figure 6 includes the additional traffic anticipated to be generated by the subject residential project.

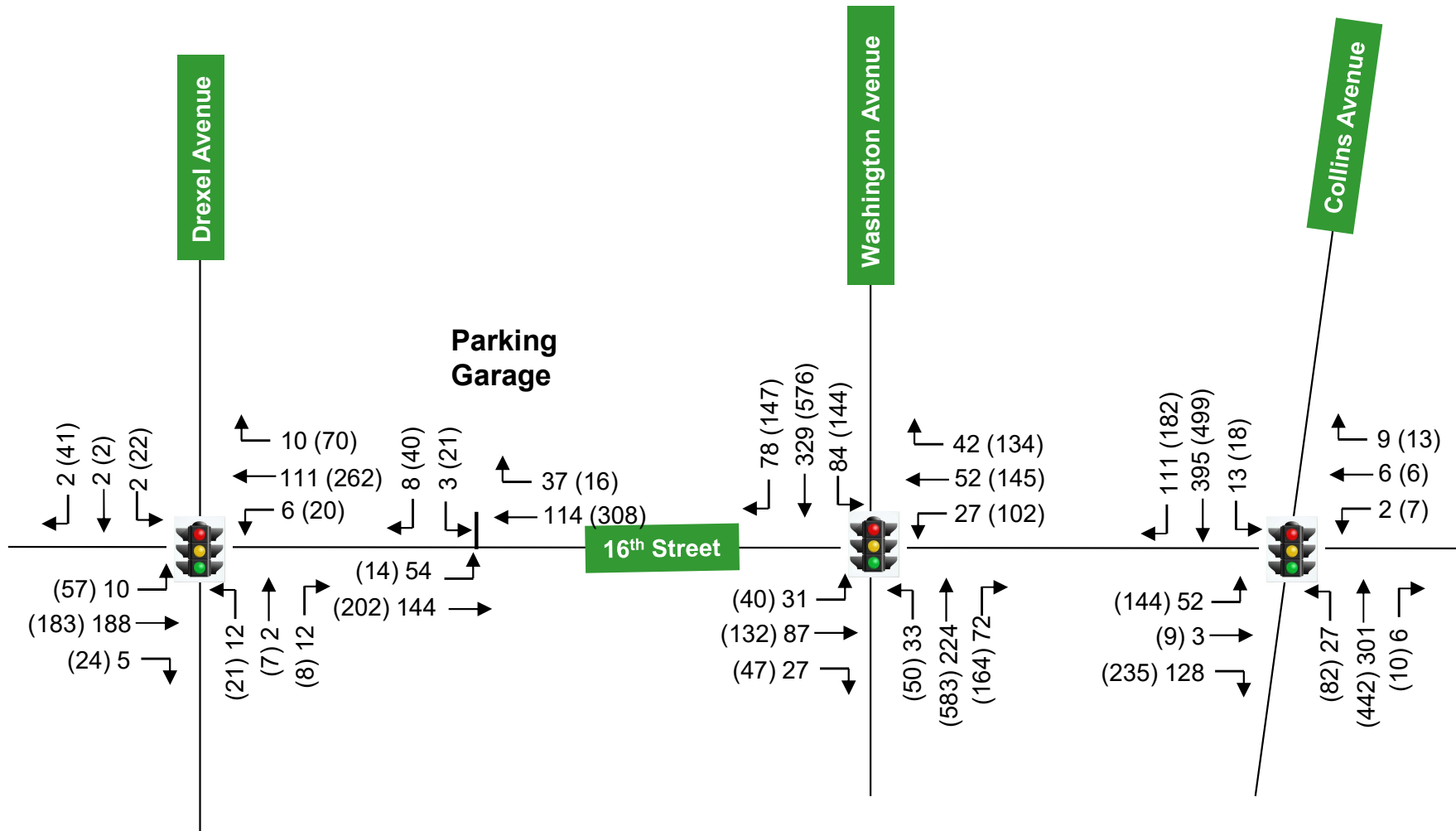

Background Traffic (2028)

FIGURE 5
1826 Collins Avenue
Miami Beach, Florida

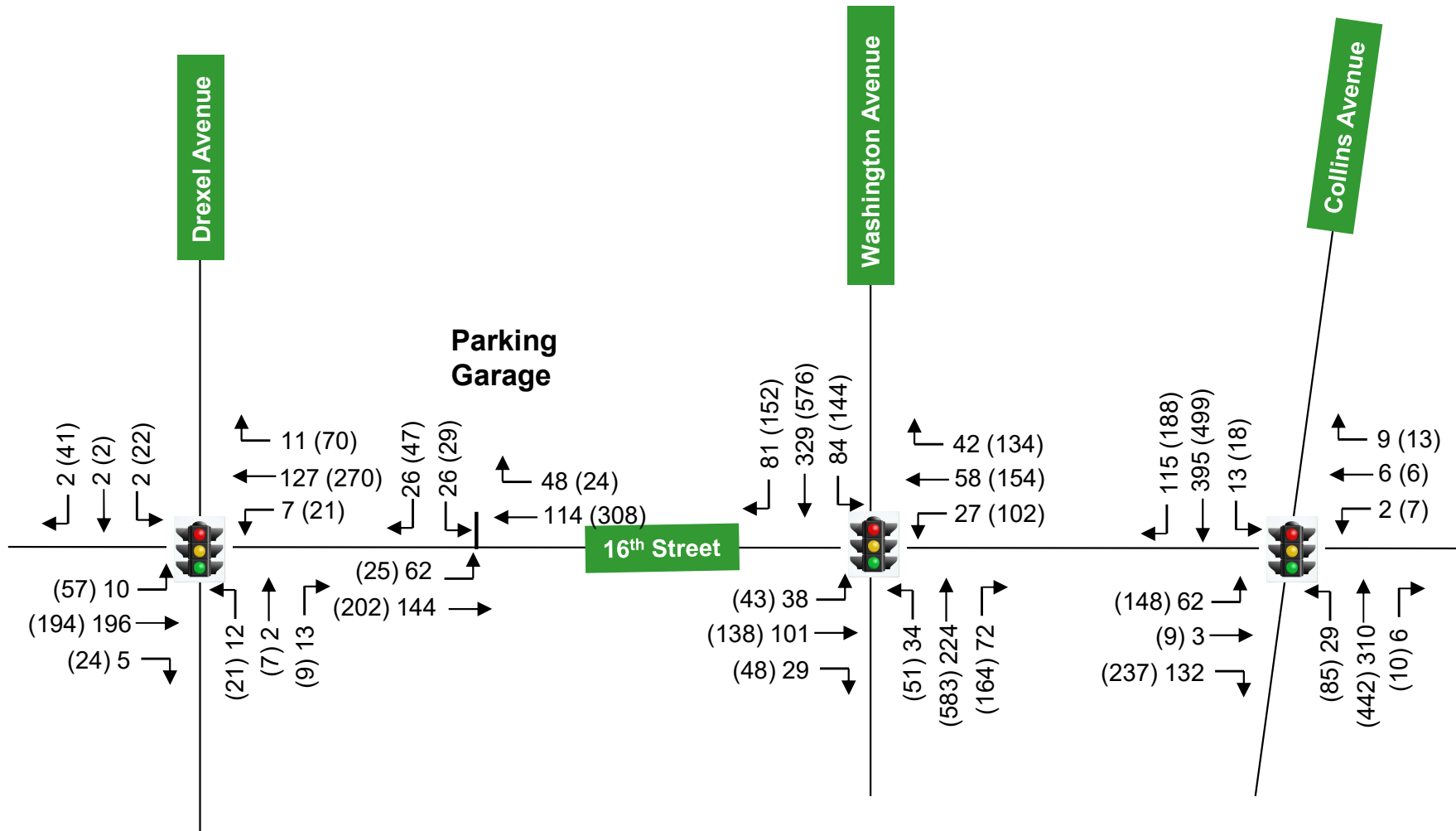

LEGEND	
XX	AM Peak Hour
(YY)	PM Peak Hour

Level of Service Analyses

Intersection capacity/level of service analyses were conducted for the six study intersections and access driveways. The analyses were undertaken following the capacity/level of service procedures outlined in the Highway Capacity Manual (HCS) using the SYNCHRO software. The results of the capacity analyses are summarized in Tables 4A and 4B.

As shown in Tables 4A and 4B, all study intersections are currently operating adequately and are expected to maintain a good level of service through the year 2028 with the proposed project in place with one exception during the PM peak hour. The eastbound approach at the intersection of Washington Avenue and 16th Street is projected to operate at a deficient level, even without the project, indicating background operational issues. With the addition of the project's PM peak-hour traffic (10 trips), the delay on the eastbound approach is expected to increase by 43.4 seconds, while the overall intersection delay is projected to increase by six seconds.

The computer printouts of the intersection capacity analyses are contained in Appendix F.

TABLE 4A Level of Service and Delay - AM Peak Hour															
			EB-L	EB-T	EB-R	WB-L	WB-T	WB-R	NB-L	NB-T	NB-R	SB-L	SB-T	SB-R	
101: Drexel Avenue & 16 Street*	Existing	Movement Delay (s/veh)													
		Movement LOS													
		Approach Delay (s/veh)	10.0			9.0			37.4			36.8			
		Approach LOS	A			A			D			D			
		Intersection Delay (s/veh)	12.2												
	Intersection LOS	B													
	Background	Movement Delay (s/veh)													
		Movement LOS													
		Approach Delay (s/veh)	10.0			9.0			37.4			36.8			
		Approach LOS	A			A			D			D			
		Intersection Delay (s/veh)	12.2												
	Intersection LOS	B													
	Future	Movement Delay (s/veh)													
		Movement LOS													
		Approach Delay (s/veh)	10.1			9.2			37.4			36.8			
Approach LOS		B			A			D			D				
Intersection Delay (s/veh)		12.2													
Intersection LOS	B														
102: 16 Street & Garage Entrance	Existing	Movement Delay (s/veh)	7.9	0	0	0	10.7	8.7							
		Movement LOS	A				B	A							
		Approach Delay (s/veh)	2.17		0		9.28								
		Approach LOS					A								
		Intersection Delay (s/veh)	12.2												
	Intersection LOS	B													
	Background	Movement Delay (s/veh)	7.9	0	0	0	10.7	8.7							
		Movement LOS	A				B	A							
		Approach Delay (s/veh)	2.17		0		9.28								
		Approach LOS					A								
		Intersection Delay (s/veh)	12.2												
	Intersection LOS	B													
	Future	Movement Delay (s/veh)	8	0	0	0	11.3	8.8							
		Movement LOS	A				B	A							
		Approach Delay (s/veh)	2.41		0		10.05								
Approach LOS						B									
Intersection Delay (s/veh)		12.2													
Intersection LOS	B														
103: Washington Avenue & 16 Street	Existing	Movement Delay (s/veh)	26.8	0.0	0.0	24.7	0.0	21.0	11.7	12.7	13.1	12.4	6.9	7.1	
		Movement LOS	C			C		C	B	B	B	B	A	A	
		Approach Delay (s/veh)	26.8			23.5			12.8			7.9			
		Approach LOS	C			C			B			A			
		Intersection Delay (s/veh)	13.6												
	Intersection LOS	B													
	Background	Movement Delay (s/veh)	26.8	0.0	0.0	24.7	0.0	21.0	11.7	12.7	13.1	12.4	6.9	7.1	
		Movement LOS	C			C		C	B	B	B	B	A	A	
		Approach Delay (s/veh)	26.8			23.5			12.8			7.9			
		Approach LOS	C			C			B			A			
		Intersection Delay (s/veh)	13.6												
	Intersection LOS	B													
	Future	Movement Delay (s/veh)	27.3	0.0	0.0	24.8	0.0	20.9	11.8	12.8	13.1	12.4	7.0	7.2	
		Movement LOS	C			C		C	B	B	B	B	A	A	
		Approach Delay (s/veh)	27.3			23.5			12.8			8.0			
Approach LOS		C			C			B			A				
Intersection Delay (s/veh)		14.1													
Intersection LOS	B														
104: Collins Ave & 16 Street	Existing	Movement Delay (s/veh)	35.1	0.0	39.9	42.3	0.0	32.8	1.9	0.0	2.0	2.2	0.0	2.5	
		Movement LOS	D		D	D		C	A		A	A		A	
		Approach Delay (s/veh)	38.5			33.9			2.0			2.3			
		Approach LOS	D			C			A			A			
		Intersection Delay (s/veh)	8.9												
	Intersection LOS	A													
	Background	Movement Delay (s/veh)	35.1	0.0	39.9	42.3	0.0	32.8	1.9	0.0	2.0	2.2	0.0	2.5	
		Movement LOS	D		D	D		C	A		A	A		A	
		Approach Delay (s/veh)	38.5			33.9			2.0			2.3			
		Approach LOS	D			C			A			A			
		Intersection Delay (s/veh)	8.9												
	Intersection LOS	A													
	Future	Movement Delay (s/veh)	35.5	0.0	40.7	42.7	0.0	32.7	2.0	0.0	2.0	2.2	0.0	2.5	
		Movement LOS	D		D	D		C	A		A	A		A	
		Approach Delay (s/veh)	39.0			33.9			2.0			2.3			
Approach LOS		D			C			A			A				
Intersection Delay (s/veh)		9.4													
Intersection LOS	A														

* HCM 2000 Results due to exclusive pedestrian phase

TABLE 2B Level of Service and Delay - PM Peak Hour														
			EB-L	EB-T	EB-R	WB-L	WB-T	WB-R	NB-L	NB-T	NB-R	SB-L	SB-T	SB-R
101: Drexel Avenue & 16 Street	Existing	Mov. Delay (s/veh)	3.8	0.0	0.0	4.4	0.0	0.0	20.6	0.0	0.0	20.4	0.0	0.0
		Mov. LOS	A			A			C			C		
		App. Delay (s/veh)	3.8			4.4			20.6			20.4		
		App. LOS	A			A			C			C		
		Int. Delay (s/veh)	5.9											
	Int. LOS	A												
	Background	Mov. Delay (s/veh)	4.4	0.0	0.0	4.9	0.0	0.0	20.4	0.0	0.0	21.1	0.0	0.0
		Mov. LOS	A			A			C			C		
		App. Delay (s/veh)	4.4			4.9			20.4			21.1		
		App. LOS	A			A			C			C		
		Int. Delay (s/veh)	7.0											
	Int. LOS	A												
	Future	Mov. Delay (s/veh)	4.5	0.0	0.0	4.9	0.0	0.0	20.5	0.0	0.0	21.1	0.0	0.0
		Mov. LOS	A			A			C			C		
		App. Delay (s/veh)	4.5			4.9			20.5			21.1		
App. LOS		A			A			C			C			
Int. Delay (s/veh)		7.0												
Int. LOS	A													
102: 16 Street & Garage Entrance	Existing	Mov. Delay (s/veh)	8.4	0				11.6	9.8					
		Mov. LOS	A	A				B	A					
		Approach Delay (s/veh)	0.64		0		10.42							
	Approach LOS	B												
	Background	Mov. Delay (s/veh)	8.5	0				12.3	9.9					
		Mov. LOS	A	A				B	A					
		Approach Delay (s/veh)	0.55		0		10.74							
	Approach LOS	B												
	Future	Mov. Delay (s/veh)	8.6	0				12.7	10					
		Mov. LOS	A	A				B	B					
Approach Delay (s/veh)		0.95		0		11.05								
Approach LOS	B													
103: Washington Avenue & 16 Street	Existing	Mov. Delay (s/veh)	39.0	0.0	0.0	35.9	0.0	31.9	8.8	10.2	10.4	10.8	5.3	5.7
		Mov. LOS	D			D			A	B	B	B	A	A
		Approach Delay (s/veh)	39.0			34.3			10.2			5.9		
		Approach LOS	D			C			B			A		
		Intersection Delay (s/veh)	14.5											
	Intersection LOS	B												
	Background	Mov. Delay (s/veh)	309.3	0.0	0.0	92.1	0.0	32.0	9.2	11.7	12.3	12.1	5.4	5.7
		Mov. LOS	F			F		C	A	B	B	B	A	A
		Approach Delay (s/veh)	309.3			70.9			11.8			6.6		
		Approach LOS	F			E			B			A		
		Intersection Delay (s/veh)	48.6											
	Intersection LOS	D												
	Future	Mov. Delay (s/veh)	352.7	0.0	0.0	94.9	0.0	32.0	9.2	11.7	12.3	12.1	5.4	5.7
		Mov. LOS	F			F		C	A	B	B	B	A	A
		App. Delay (s/veh)	352.7			73.2			11.8			6.6		
App. LOS		F			E			B			A			
Int. Delay (s/veh)		54.4												
Int. LOS	D													
104: Collins Avenue & 16 Street	Existing	Mov. Delay (s/veh)	39.0	0.0	35.4	37.6	0.0	32.7	2.5	0.0	2.5	2.5	0.0	3.1
		Mov. LOS	D		D	D		C	A		A	A		A
		Approach Delay (s/veh)	37.7			34.1			2.5			2.8		
		Approach LOS	D			C			A			A		
		Intersection Delay (s/veh)	8.3											
	Intersection LOS	A												
	Background	Mov. Delay (s/veh)	35.4	0.0	83.1	49.5	0.0	29.4	4.3	0.0	4.1	4.4	0.0	5.4
		Mov. LOS	D		F	D		C	A		A	A		A
		Approach Delay (s/veh)	65.4			34.8			4.2			4.8		
		Approach LOS	E			C			A			A		
		Intersection Delay (s/veh)	19.3											
	Intersection LOS	B												
	Future	Mov. Delay (s/veh)	35.6	0.0	85.2	49.8	0.0	29.4	4.4	0.0	4.2	4.4	0.0	5.5
		Mov. LOS	D		F	D		C	A		A	A		A
		App. Delay (s/veh)	66.6			34.9			4.3			4.8		
App. LOS		E			C			A			A			
Int. Delay (s/veh)		19.8												
Int. LOS	B													

Parking

Parking will be available at the parking garage located at 1601 Drexel Avenue, directly adjacent to the proposed development. The garage operates 24 hours a day, seven days a week. Additionally, six on-street parking spaces are located along the north side of 16th Street and may be utilized by retail patrons.

Maneuverability Analysis

The maneuverability analysis was undertaken using the AutoTURN software. Software runs for the garbage and deliveries are shown in Appendix B. The trucks will use the alley located west of the project site (just east of the existing parking garage).

Queuing and Valet services

The proposed project does not include gate installations. Parking will occur at the existing parking garage located immediately west of the project site.

Transportation Demand Management (TDM)

Traf Tech Engineering, Inc. prepared a Transportation Demand Management (TDM) plan for the 1600 Washington project.

Travel Demand Management plans (TDM) establish policies and mechanisms to reduce automobile trips to and from designated facilities. TDM plans usually use several approaches to address all modes of transportation likely to be used to provide access to a facility such as single occupant driving, carpooling, transit, bicycling and walking. The goal of TDM plans is to increase the use of alternatives modes to single occupant driving, i.e., to reduce the number of automobile trips to and from the facility and consequently, minimizing automobile traffic impacts on the street system.

Successful TDM plans not only address all modes of transportation but also use policies such as inducements for alternative modes (subsidies), physical enhancements (bike lockers, preferential parking for carpools) and disincentives for automobile use (no free parking for employees). Potential measures for each mode are addressed below. Use of an employee transportation subsidy is also presented.

Pedestrian Access

Walking not only reduces automobile trips and their contribution to congestion and emissions, it also provides health benefits to the employees who use this mode of transportation. It is, however, the mode that is least likely to be used for a number of reasons. It is unlikely that employees of the commercial building use will reside within a reasonable walking distance (within $\frac{1}{4}$ - $\frac{1}{2}$ mile) of the subject facility. However, the area near the subject project is a high pedestrian traffic area and therefore, many existing and future customers of the 1600 Washington development are expected to be walking trips. Sidewalks exist on the north and south sides of 16th Street (the front of the building is on 16th Street) as well as safe pedestrian crosswalks (with ramps and pedestrian signals) at the adjacent signalized intersections of Washington Avenue & 16th Street, Drexel Avenue & 16th Street, and Collins Avenue & 16th Street.

Bicycling

The site of the 1600 Washington project offers two potential approaches to encourage cycling. Bicycle parking is provided on the ground floor of the parking garage and 20 new micromobility stations will be provided adjacent to the site.

Additionally, use of Citi Bike could be supported by providing monthly passes to employees. Monthly passes are \$15.00 for unlimited 30-minute rides and \$25.00 for unlimited 60-minute rides. Within the immediate area of the project, there is one (1) convenient Citi Bike rental station located at the corner of Collins Avenue and 15th Street) and employees will be informed of the Citi Bike Stations.

(Goal: Offer 2 free City Bike passes to retail employees. Integrate bikeshare information into communication materials for retail patrons).

Mass Transit

Currently, Miami-Dade Transit (MDT) route 14 serves the study area. Route 14 travels north and south along Washington Avenue. The nearest bus stop is located on Washington Avenue, north of 16th Street.

CONCLUSIONS AND RECOMMENDATIONS

1600 Washington is a proposed mixed-use development planned to be located at 1600 Washington Avenue in the City of Miami Beach in Miami-Dade County, Florida. The project site is currently developed with commercial uses (approximately 9,810 square feet). This site was previously approved with residential/retail uses generating approximately 796 daily trips and approximately 81 PM peak hour trips. The proposed project consists of 210 high-rise residential units and 6,900 square feet of retail.

The conclusions of the traffic study are presented below:

- The external new trips anticipated to be generated by the proposed development during the AM peak hour includes approximately 60 peak-hour trips (19 inbound and 41 outbound) and during the PM peak hour includes approximately 46 trips (27 inbound and 19 outbound).
- All study intersections are currently operating adequately and are expected to maintain a good level of service through the year 2028 with the proposed project in place with one exception during the PM peak hour. The eastbound approach at the intersection of Washington Avenue and 16th Street is projected to operate at a deficient level, even without the project, indicating background operational issues. With the addition of the project's PM peak-hour traffic (10 trips), the delay on the eastbound approach is expected to increase by 43.4 seconds, while the overall intersection delay is projected to increase by six seconds.
- Parking will be available at the parking garage located at 1601 Drexel Avenue, directly adjacent to the proposed development. Additionally, six on-street parking spaces are located along the north side of 16th Street and may be utilized by retail patrons.

APPENDIX A
Traffic Methodology



1600 Washington

Miami Beach, Florida 33140

prepared for:

Beilingson Gomez Architects

traffic methodology

TRAFTECH
ENGINEERING, INC.

May 2025

PROPOSED TRAFFIC METHODOLOGY
1600 Washington Avenue
Miami Beach, Florida

PROJECT DESCRIPTION

The project site is currently developed with commercial uses (approximately 9,810 square feet). This site was previously approved with residential/retail uses generating approximately 796 daily trips and approximately 81 PM peak hour trips. Proposed for the project is a mixed-use project consisting of up to 210 high-rise residential units and approximately 6,947 square feet of retail use. Attachment A contains a copy of the latest site plan for the project.

PROPOSED TRAFFIC METHODOLOGY

- A trip generation comparison analysis between existing development at the site, and the proposed development program was performed using the Institute of Transportation Engineers (ITE) *Trip Generation Manual (11th Edition)*. Table 1 documents the trips associated with the existing retail use at the site. Table 2 documents the trip generation associated with the new updated uses and intensities using ITE 11th Edition. The trip generation, internal capture and pass-by evaluation is contained in Attachment B.
- The trip distribution and assignment of project traffic will be based upon the applicable TAZ data contained within the Long-Range Transportation Plan (LRTP) published by the Miami-Dade MPO. The distribution will be interpolated between the 2015 and 2045 model years for the appropriate buildout year (tentatively estimated to be 2025).
- The subject traffic study will evaluate the following intersections during the typical AM and PM peak periods:
 - Washington Avenue and 16th Street (signalized)
 - Drexel Avenue and 16th Street (signalized)
 - Collins Avenue and 16th Street (signalized)
 - Parking garage entrance and 16th Street (stop control)
- Traffic counts will be adjusted to reflect average peak season conditions based upon the most recent available FDOT adjustment factors.

- A growth factor will be applied to the traffic counts to reflect future traffic conditions at project build-out. The growth factor will be based upon historical traffic data available for the area near the project site. ✓

The growth rate analysis using FDOT count stations will evaluate linear, exponential, and decaying exponential growth rates for the most recent five-year and ten-year periods. The historical growth analysis will be compared to 2015 and 2045 FSUTMS SERPM volume growth in order to select a conservative growth rate for the project.

- Traffic associated with the following committed developments will be used: 1620 Drexel, 1501 Washington, Lenox Road (300 Blocks)
- Existing traffic signal timing data for the study intersections will be obtained from Miami-Dade County DTPW and will be included in the Appendix of the traffic study.
- Traffic analysis will be prepared for each of the study intersections and project driveways for the following scenarios:
 - Existing (2025) traffic conditions
 - Background traffic conditions for buildout year (2028)
 - Future conditions with growth rate, committed development and project traffic for the buildout year (2028)
- The level of service and delay for the study intersections will be summarized by movement and approach as well as for the overall intersection. If necessary, mitigation of impacts will be recommended.
- Intersection analyses will be conducted using the SYNCHRO software (Synchro 12, or latest version) for existing conditions, future conditions without the project, and future conditions with the proposed project in place. The Highway Capacity Manual (HCM) 7th Edition or 2000 will be used, as applicable. Synchro files will be provided as part of the traffic study.
- A parking description (required vs provided) will be documented in the traffic study.
- Queuing at entry gates, if applicable, will be addressed in the traffic study. Existing and projected queues will be documented.

- The traffic study will address loading areas and garbage pickup (description, locations and maneuverability analysis using the AutoTURN software).
- The traffic study will include a multimodal section addressing non-automobile modes of transportation. Transportation Demand Management (TDM) strategies will be included in the traffic study.
- A Traffic Control Plan (TCP) depicting proposed signing and markings within the parking areas and access driveways will be included in the traffic study, if applicable.
- No valet service is proposed (valet analysis will not be performed).
- The results of the traffic study will be documented in a technical report. All traffic data obtained for this project will be included in the Appendix of the traffic report.

ATTACHMENT A

Site Plan for 1600 Washington

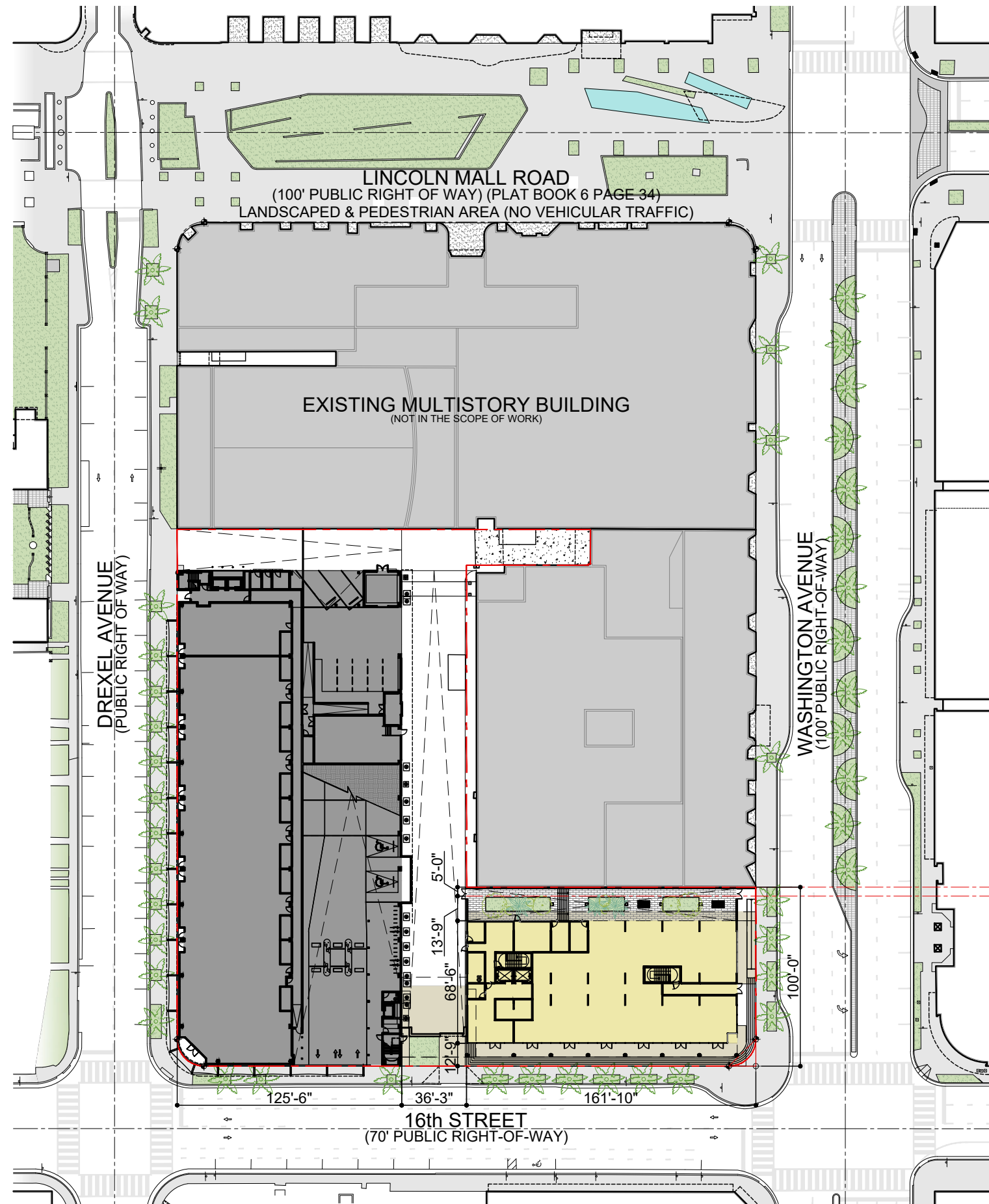

SITE PLAN LEGEND

- PROPOSED NEW BUILDING
- PROPOSED NEW BUILDING - ABOVE STORIES PROJECTION
- EXISTING PARKING GARAGE BUILDING TO REMAIN
- EXISTING ADJACENT BUILDINGS (NO PART OF THE SCOPE)
- PROPERTY LINE
- PROPERTY LINE/SETBACKS



OVERALL SITE PLAN
SCALE: 1/32" = 1'-0"

TEN ARQUITECTOS
Cuernavaca 114-PB, Col. Condesa, C.P. 06140, México D.F.
T (55) 5211.80.04 F (55) 5286.17.35

1600 WASHINGTON AVE
1600 WASHINGTON AVE
MIAMI BEACH



DWG. TITLE	OVERALL PROPOSED SITE PLAN
SCALE	VARIES
DATE	01-15-25
PROJECT NO.	
SHEET NUMBER	2025-03
DATE	REVISION

A-100

ATTACHMENT B

Trip Generation and Internal Capture

TABLE 1 Trip Generation Summary (Existing at Site) 1600 Collins								
Land Use	Size	Daily Trips	AM Peak Hour			PM Peak Hour		
			Total Trips	Inbound	Outbound	Total Trips	Inbound	Outbound
Retail <40k (LUC 822)	9,810 sf	644	28	17	11	77	39	38
Gross/Driveway Trips		644	28	17	11	77	39	38
Pass-by (25%) - PM Only		-161	0	0	0	-20	-10	-10
External Trips		483	28	17	11	57	29	28

Source: ITE Trip Generation Manual (11th Edition)

NOTE: ITE Has no pass-by data for LUC 822,used 25%

TABLE 2 Trip Generation Summary (Proposed) 1600 Washington								
Land Use	Size	Daily Trips	AM Peak Hour			PM Peak Hour		
			Total Trips	Inbound	Outbound	Total Trips	Inbound	Outbound
Residential High-Rise (LUC 222)	210 units	1,167	65	22	43	78	44	34
Retail <40k (LUC 822)	6,947 sf	523	23	14	9	60	30	30
Gross Trips		1,690	88	36	52	138	74	64
Internal Trips		-269	0	0	0	-22	-11	-11
Driveway Trips		1,421	88	36	52	116	63	53
Pass-by (25%) - PM Only		-159	0	0	0	-13	-7	-6
External Trips		1,262	88	36	52	103	56	47

Source: ITE Trip Generation Manual (11th Edition)

NOTE: ITE Has no pass-by data for LUC 822,used 25%

Difference (Proposed - Existing)	Daily	AM Peak Hour			PM Peak Hour		
	Trips	Total Trips	Inbound	Outbound	Total Trips	Inbound	Outbound
Driveway Trips	777	60	19	41	39	24	15
External Trips	779	60	19	41	46	27	19

TRIP GENERATION MANUAL 11TH EDITION

ITE Land Use Code 222 - Multifamily High-Rise)

Daily Trips: $T = 3.76 (X) + 377.04$, X = number of units

AM Peak: $T = 0.22 (X) + 18.85$ (34% inbound and 66% outbound), X = number of units

PM Peak: $T = 0.26 (X) + 23.12$ (56% inbound and 44% outbound), X = number of units

ITE Land Use Code 822 Retail (<40k)

Daily Trips: $T = 42.20 (X) + 229.68$, X = 1,000 square feet

AM Peak: $\ln (T) = 0.66 \ln (X) + 1.84$ (60% inbound and 40% outbound), X = 1,000 square feet

PM Peak: $\ln (T) = 0.71 \ln (X) + 2.72$ (50% inbound and 50% outbound), X = 1,000 square feet

NCHRP 8-51 Internal Trip Capture Estimation Tool						
Project Name:	1600 Collins			Organization:	Traf Tech Engineering, Inc.	
Project Location:	Miami Beach			Performed By:	J. Vargas	
Scenario Description:	Proposed Uses			Date:	4/16/2025	
Analysis Year:	2025			Checked By:	J. Vargas	
Analysis Period:	AM Street Peak Hour			Date:	4/16/2025	

Table 1-A: Base Vehicle-Trip Generation Estimates (Single-Use Site Estimate)						
Land Use	Development Data (For Information Only)			Estimated Vehicle-Trips		
	ITE LUCs ¹	Quantity	Units	Total	Entering	Exiting
Office				0		
Retail	822	6,947	sf	23	14	9
Restaurant				0		
Cinema/Entertainment				0		
Residential	222	210	units	65	22	43
Hotel				0		
All Other Land Uses ²				0		
Total				88	36	52

Table 2-A: Mode Split and Vehicle Occupancy Estimates						
Land Use	Entering Trips			Exiting Trips		
	Veh. Occ.	% Transit	% Non-Motorized	Veh. Occ.	% Transit	% Non-Motorized
Office						
Retail						
Restaurant						
Cinema/Entertainment						
Residential						
Hotel						
All Other Land Uses ²						

Table 3-A: Average Land Use Interchange Distances (Feet Walking Distance)						
Origin (From)	Destination (To)					
	Office	Retail	Restaurant	Cinema/Entertainment	Residential	Hotel
Office						
Retail						
Restaurant						
Cinema/Entertainment						
Residential						
Hotel						

Table 4-A: Internal Person-Trip Origin-Destination Matrix*						
Origin (From)	Destination (To)					
	Office	Retail	Restaurant	Cinema/Entertainment	Residential	Hotel
Office		0	0	0	0	0
Retail	0		0	0	0	0
Restaurant	0	0		0	0	0
Cinema/Entertainment	0	0	0		0	0
Residential	0	0	0	0		0
Hotel	0	0	0	0	0	

Table 5-A: Computations Summary			
	Total	Entering	Exiting
All Person-Trips	88	36	52
Internal Capture Percentage	0%	0%	0%
External Vehicle-Trips ³	88	36	52
External Transit-Trips ⁴	0	0	0
External Non-Motorized Trips ⁴	0	0	0

Table 6-A: Internal Trip Capture Percentages by Land Use		
Land Use	Entering Trips	Exiting Trips
Office	N/A	N/A
Retail	0%	0%
Restaurant	N/A	N/A
Cinema/Entertainment	N/A	N/A
Residential	0%	0%
Hotel	N/A	N/A

¹Land Use Codes (LUCs) from *Trip Generation Informational Report*, published by the Institute of Transportation Engineers.

²Total estimate for all other land uses at mixed-use development site-not subject to internal trip capture computations in this estimator

³Vehicle-trips computed using the mode split and vehicle occupancy values provided in Table 2-A

⁴Person-Trips

*Indicates computation that has been rounded to the nearest whole number.

Estimation Tool Developed by the Texas Transportation Institute

NCHRP 8-51 Internal Trip Capture Estimation Tool					
Project Name:	1600 Collins			Organization:	Traf Tech Engineering, Inc.
Project Location:	Miami Beach			Performed By:	J. Vargas
Scenario Description:	Proposed Uses			Date:	4/16/2025
Analysis Year:	2025			Checked By:	J. Vargas
Analysis Period:	PM Street Peak Hour			Date:	4/16/2025

Table 1-P: Base Vehicle-Trip Generation Estimates (Single-Use Site Estimate)						
Land Use	Development Data (For Information Only)			Estimated Vehicle-Trips		
	ITE LUCs ¹	Quantity	Units	Total	Entering	Exiting
Office				0		
Retail	822	6,947	sf	60	30	30
Restaurant				0		
Cinema/Entertainment				0		
Residential	222	210	units	78	44	34
Hotel				0		
All Other Land Uses ²				0		
Total				138	74	64

Table 2-P: Mode Split and Vehicle Occupancy Estimates						
Land Use	Entering Trips			Exiting Trips		
	Veh. Occ.	% Transit	% Non-Motorized	Veh. Occ.	% Transit	% Non-Motorized
Office						
Retail						
Restaurant						
Cinema/Entertainment						
Residential						
Hotel						
All Other Land Uses ²						

Table 3-P: Average Land Use Interchange Distances (Feet Walking Distance)						
Origin (From)	Destination (To)					
	Office	Retail	Restaurant	Cinema/Entertainment	Residential	Hotel
Office						
Retail						
Restaurant						
Cinema/Entertainment						
Residential						
Hotel						

Table 4-P: Internal Person-Trip Origin-Destination Matrix*						
Origin (From)	Destination (To)					
	Office	Retail	Restaurant	Cinema/Entertainment	Residential	Hotel
Office		0	0	0	0	0
Retail	0		0	0	8	0
Restaurant	0	0		0	0	0
Cinema/Entertainment	0	0	0		0	0
Residential	0	3	0	0		0
Hotel	0	0	0	0	0	

Table 5-P: Computations Summary			
	Total	Entering	Exiting
All Person-Trips	138	74	64
Internal Capture Percentage	16%	15%	17%
External Vehicle-Trips ³	116	63	53
External Transit-Trips ⁴	0	0	0
External Non-Motorized Trips ⁴	0	0	0

Table 6-P: Internal Trip Capture Percentages by Land Use		
Land Use	Entering Trips	Exiting Trips
Office	N/A	N/A
Retail	10%	27%
Restaurant	N/A	N/A
Cinema/Entertainment	N/A	N/A
Residential	18%	9%
Hotel	N/A	N/A

¹Land Use Codes (LUCs) from *Trip Generation Informational Report*, published by the Institute of Transportation Engineers.

²Total estimate for all other land uses at mixed-use development site-not subject to internal trip capture computations in this estimator

³Vehicle-trips computed using the mode split and vehicle occupancy values provided in Table 2-P

⁴Person-Trips

*Indicates computation that has been rounded to the nearest whole number.

Estimation Tool Developed by the Texas Transportation Institute

APPENDIX B

Site Plan – 1600 Washington and AutoTURN Analyses

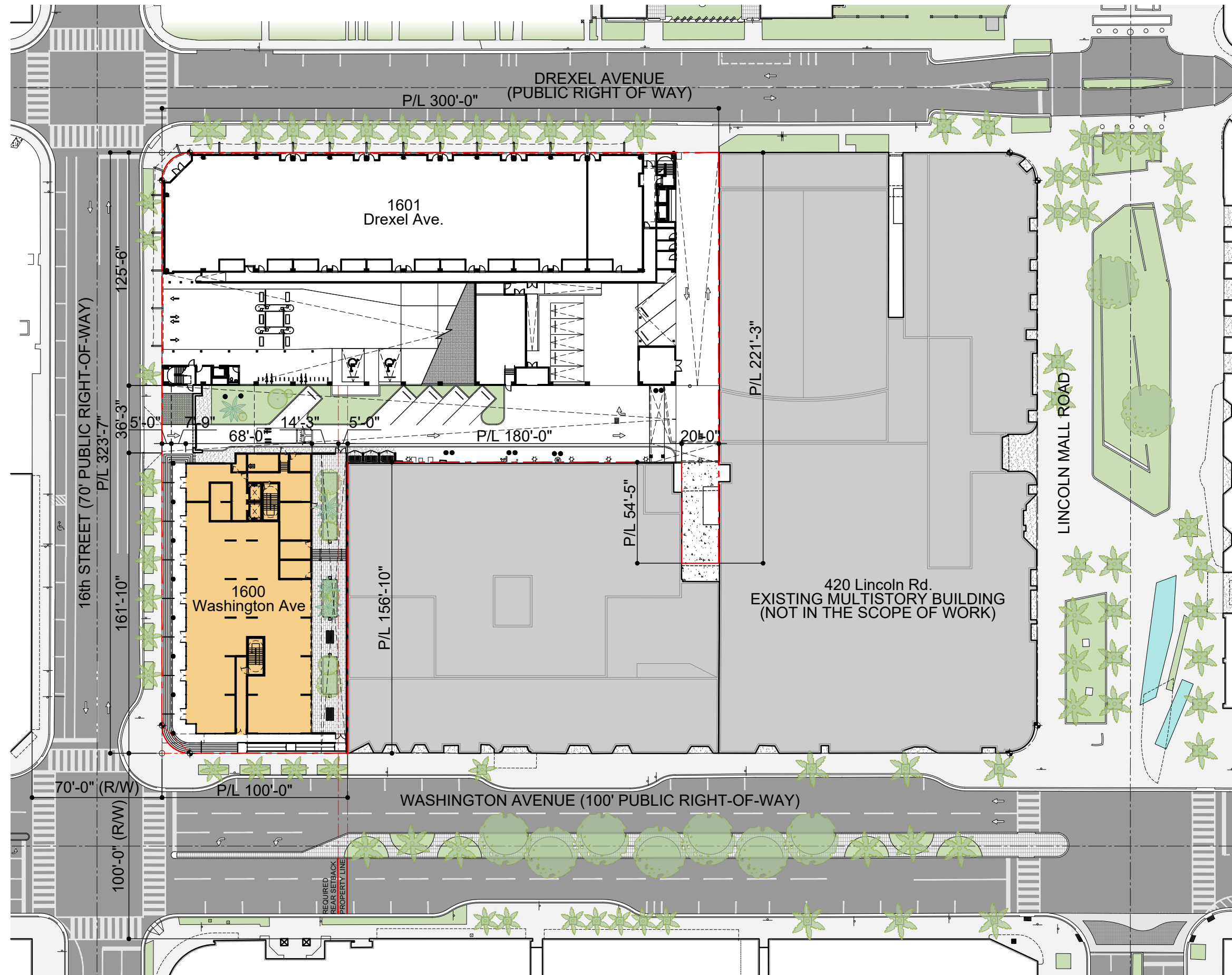

- SITE PLAN LEGEND**
- PROPOSED NEW BUILDING
 - EXISTING PARKING GARAGE BUILDING TO REMAIN
 - EXISTING ADJACENT BUILDINGS (NO PART OF THE SCOPE)
 - PROPERTY LINE
 - PROPERTY LINE/SETBACKS

OVERALL SITE PLAN
SCALE: 1" = 300'

TEN ARQUITECTOS
Cuernavaca 114-PB, Col. Condesa, C.P. 06140, México D.F.
T (55) 5211.80.04 F (55) 5286.17.35

1600 WASHINGTON AVE
1600 WASHINGTON AVE
MIAMI BEACH



DATE	REVISION

DWG. TITLE: PROPOSED OVERALL SITE PLAN
SCALE: VARIES
DATE: 01-15-25
PROJECT NO.: 2025-03
SHEET NUMBER: A-100

COPYRIGHT 2025. ALL RIGHTS RESERVED. THESE DRAWINGS AND DOCUMENTS ARE INSTRUMENTS OF SERVICE SHALL REMAIN THE PROPERTY OF BEILINSON GOMEZ ARCHITECTS P.A. WHETHER THE PROJECT FOR WHICH THEY WERE PREPARED IS EXECUTED OR NOT. THEY ARE NOT TO BE USED IN ANY MANNER ON OTHER PROJECTS OR EXTENSIONS TO THIS PROJECT EXCEPT BY AGREEMENT IN WRITING AND WITH THE APPROPRIATE COMPENSATION TO BEILINSON GOMEZ ARCHITECTS P.A. REPRODUCTIONS OF DRAWINGS AND SPECIFICATIONS WITHOUT THE WRITTEN CONSENT OF BEILINSON GOMEZ ARCHITECTS P.A. IS PROHIBITED. CONTRACTORS RESPONSIBLE FOR VERIFYING ALL SITE CONDITIONS PRIOR TO PROCEEDING WITH WORK.

ARCHITECTURE JOSE L. GOMEZ 8101 BISCAYNE BLVD. # 309, 310
A/C 001062 AR 015416 T 305.559.1255 56270112.159.4.COM



TEN ARQUITECTOS
 Cuernavaca 114-PB, Col. Condesa, C.P. 06140, México D.F.
 T (55) 5211.80.04 F (55) 5286.17.35

1600 WASHINGTON AVE
 1600 WASHINGTON AVE
 MIAMI BEACH



PROPOSED GROUND LEVEL FLOOR PLAN

DWG. TITLE	PROPOSED GROUND FLOOR PLAN
SCALE	3/32" = 1'-0"
DATE	01-15-25
PROJECT NO.	
SHEET NUMBER	2025-03

A-101

COPYRIGHT 2025. ALL RIGHTS RESERVED. THESE DRAWINGS AND DOCUMENTS ARE INSTRUMENTS OF SERVICE SHALL REMAIN THE PROPERTY OF BEILINSON GOMEZ ARCHITECTS P.A. WHETHER THE PROJECT FOR WHICH THEY WERE PREPARED IS EXECUTED OR NOT. THEY ARE NOT TO BE USED IN ANY MANNER ON OTHER PROJECTS OR EXTENSIONS TO THIS PROJECT EXCEPT BY AGREEMENT IN WRITING AND WITH THE APPROPRIATE COMPENSATION TO BEILINSON GOMEZ ARCHITECTS P.A. REPRODUCTIONS OF DRAWINGS AND SPECIFICATIONS WITHOUT THE WRITTEN CONSENT OF BEILINSON GOMEZ ARCHITECTS P.A. IS PROHIBITED. CONTRACTORS RESPONSIBLE FOR VERIFYING ALL SITE CONDITIONS PRIOR TO PROCEEDING WITH WORK.

ARCHITECTURE | JOSE L. GOMEZ 8101 BISCAYNE BLVD. S 309, 310
 AAC001062 | AR0015416 | 305.559.1255 | 5620n12.1552.com

DATE | REVISION

CONSULTANT

16th STREET (70' PUBLIC RIGHT-OF-WAY)

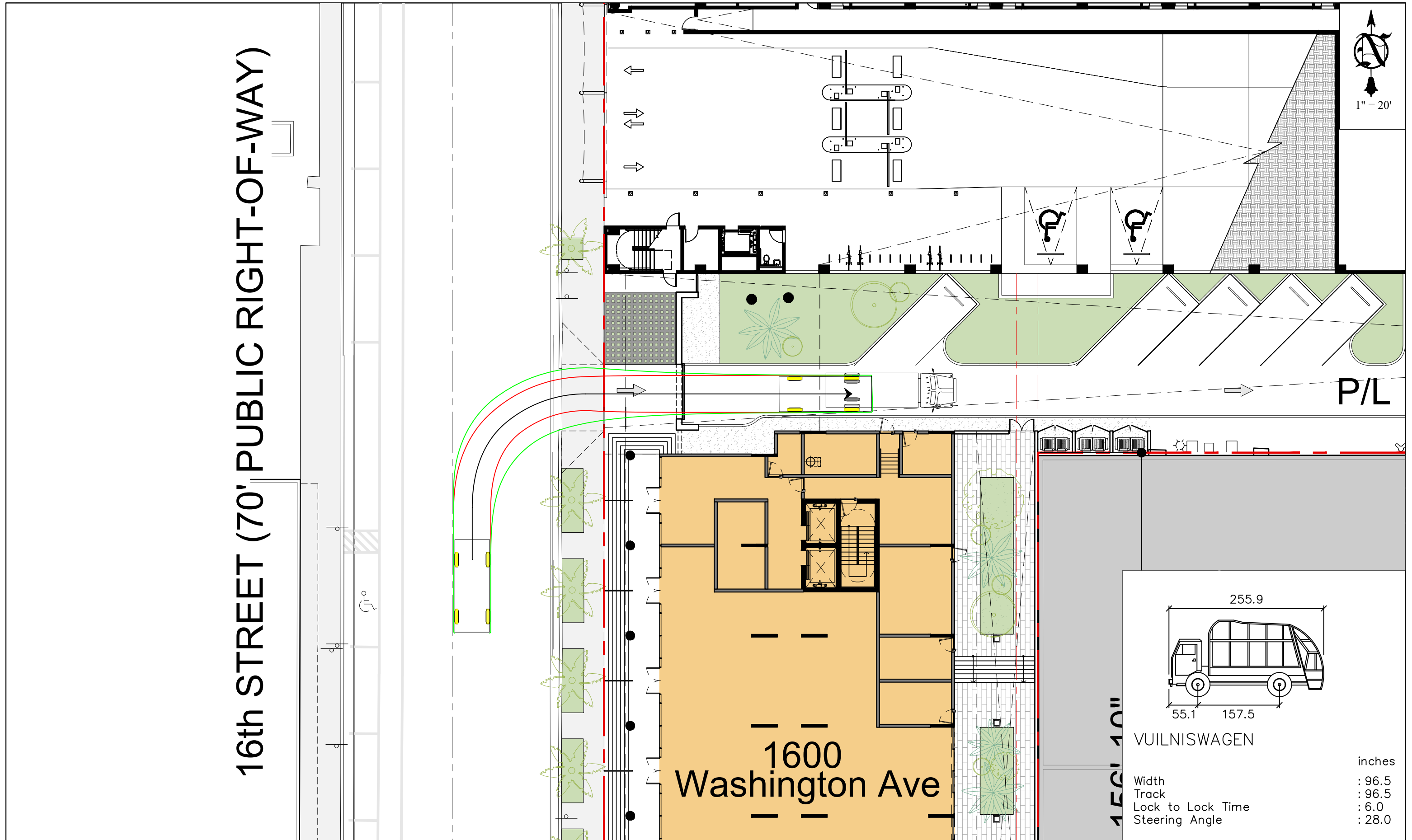

16th STREET (70' PUBLIC RIGHT-OF-WAY)

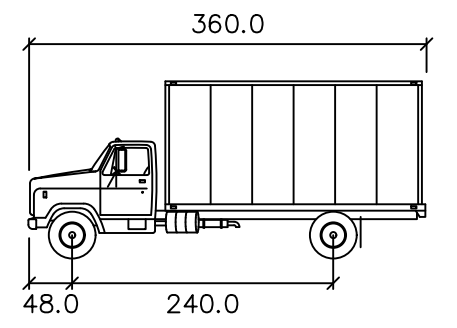
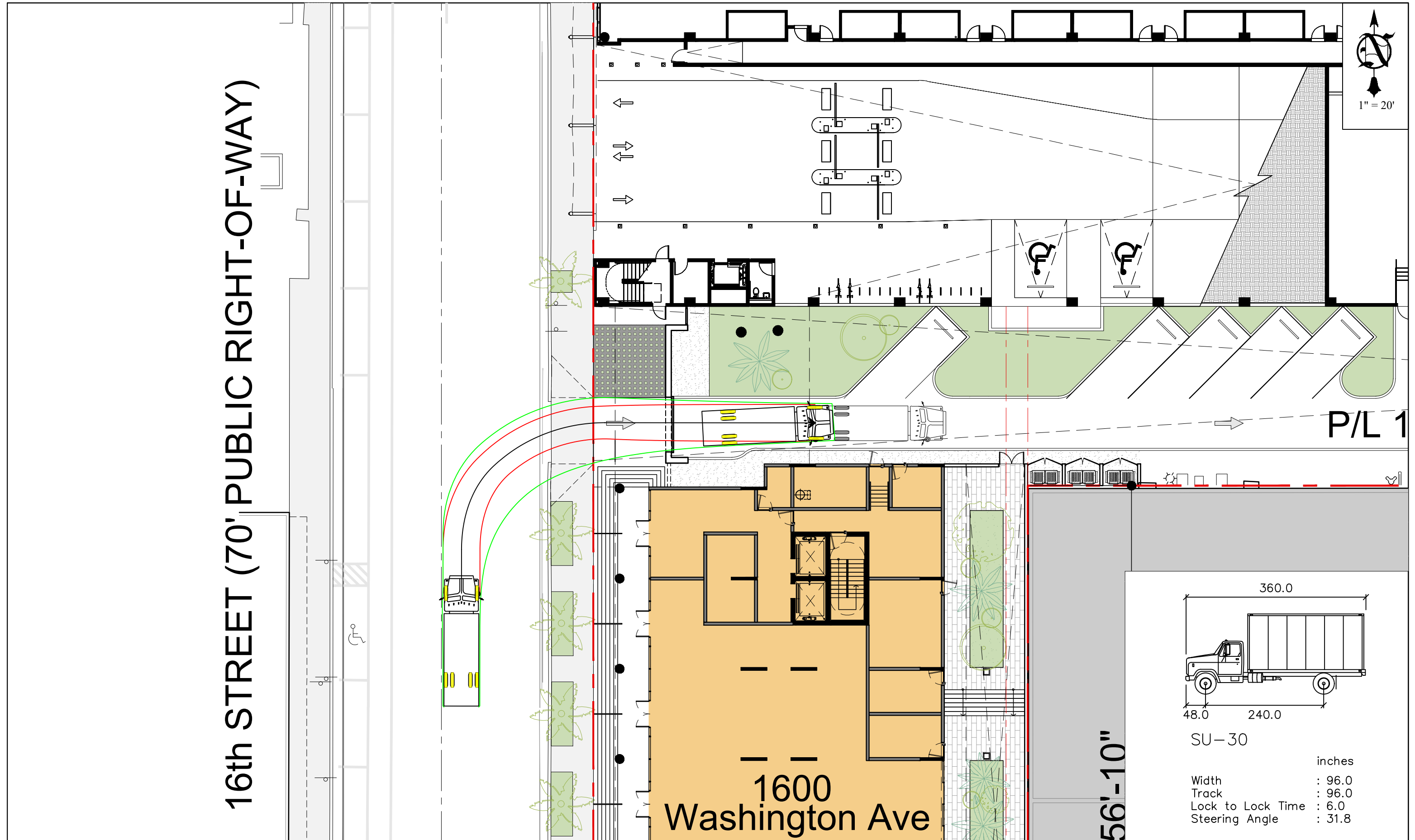

SU-30

	inches
Width	: 96.0
Track	: 96.0
Lock to Lock Time	: 6.0
Steering Angle	: 31.8

APPENDIX C

Traffic Counts and Signal Timing Plans

Traff Tech Engineering Inc.

File Name : 1-Drexel Ave & 16th St
 Site Code : 00000000
 Start Date : 6/12/2025
 Page No : 1

Groups Printed- Autos - Heavy Vehicles

Start Time	Drexel Ave From North					16th Street From East					Drexel Ave From South					16th Street From West					Int. Total
	Right	Thru	Left	U-Turns	App. Total	Right	Thru	Left	U-Turns	App. Total	Right	Thru	Left	U-Turns	App. Total	Right	Thru	Left	U-Turns	App. Total	
07:00	0	0	0	0	0	1	14	3	0	18	3	0	2	0	5	0	24	0	0	24	47
07:15	1	0	0	0	1	0	17	0	0	17	1	0	1	0	2	2	31	3	0	36	56
07:30	2	0	3	0	5	1	21	1	0	23	0	0	1	0	1	2	20	4	0	26	55
07:45	1	1	1	0	3	2	24	2	0	28	3	0	0	0	3	1	28	2	0	31	65
Total	4	1	4	0	9	4	76	6	0	86	7	0	4	0	11	5	103	9	0	117	223
08:00	0	1	0	0	1	0	23	0	0	23	4	1	0	0	5	2	22	0	0	24	53
08:15	1	0	0	0	1	7	25	1	0	33	3	0	4	1	8	0	28	1	0	29	71
08:30	1	0	1	0	2	1	27	2	0	30	1	0	0	0	1	1	43	1	0	45	78
08:45	0	1	1	0	2	1	21	2	0	24	2	1	5	0	8	1	58	7	0	66	100
Total	2	2	2	0	6	9	96	5	0	110	10	2	9	1	22	4	151	9	0	164	302

*** BREAK ***

16:00	3	1	1	0	5	5	60	3	0	68	4	0	1	0	5	4	34	2	0	40	118
16:15	2	0	0	0	2	4	51	4	0	59	3	3	6	1	13	2	30	5	0	37	111
16:30	2	0	0	0	2	8	46	6	0	60	3	1	3	1	8	5	29	7	0	41	111
16:45	2	0	0	0	2	6	41	0	1	48	5	5	1	0	11	4	35	6	1	46	107
Total	9	1	1	0	11	23	198	13	1	235	15	9	11	2	37	15	128	20	1	164	447
17:00	1	1	2	0	4	10	65	1	0	76	0	3	2	0	5	0	34	7	0	41	126
17:15	4	1	3	0	8	13	52	5	0	70	4	1	7	0	12	7	34	6	0	47	137
17:30	3	0	1	1	5	15	60	7	0	82	2	1	6	0	9	7	29	9	1	46	142
17:45	7	0	0	0	7	5	50	4	0	59	1	1	3	0	5	7	40	4	0	51	122
Total	15	2	6	1	24	43	227	17	0	287	7	6	18	0	31	21	137	26	1	185	527
Grand Total	30	6	13	1	50	79	597	41	1	718	39	17	42	3	101	45	519	64	2	630	1499
Apprch %	60	12	26	2		11	83.1	5.7	0.1		38.6	16.8	41.6	3		7.1	82.4	10.2	0.3		
Total %	2	0.4	0.9	0.1	3.3	5.3	39.8	2.7	0.1	47.9	2.6	1.1	2.8	0.2	6.7	3	34.6	4.3	0.1	42	
Autos	30	6	12	1	49	79	585	40	1	705	38	17	42	3	100	45	512	64	2	623	1477
% Autos	100	100	92.3	100	98	100	98	97.6	100	98.2	97.4	100	100	100	99	100	98.7	100	100	98.9	98.5
Heavy Vehicles	0	0	1	0	1	0	12	1	0	13	1	0	0	0	1	0	7	0	0	7	22
% Heavy Vehicles	0	0	7.7	0	2	0	2	2.4	0	1.8	2.6	0	0	0	1	0	1.3	0	0	1.1	1.5

Traff Tech Engineering Inc.

File Name : 1-Drexel Ave & 16th St

Site Code : 00000000

Start Date : 6/12/2025

Page No : 2

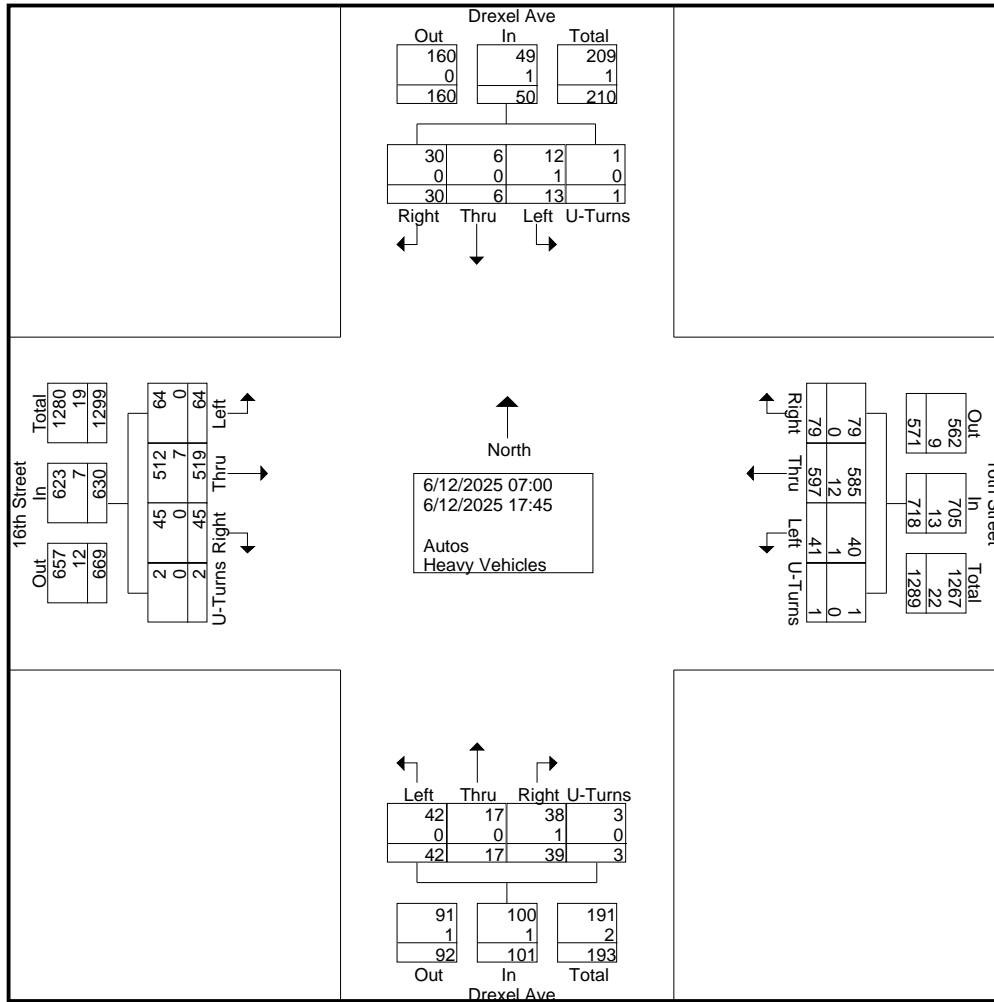

Traff Tech Engineering Inc.

File Name : 1-Drexel Ave & 16th St
 Site Code : 00000000
 Start Date : 6/12/2025
 Page No : 3

Start Time	Drexel Ave From North					16th Street From East					Drexel Ave From South					16th Street From West					Int. Total
	Right	Thru	Left	U-Turns	App. Total	Right	Thru	Left	U-Turns	App. Total	Right	Thru	Left	U-Turns	App. Total	Right	Thru	Left	U-Turns	App. Total	
Peak Hour Analysis From 07:00 to 17:45 - Peak 1 of 1																					
Peak Hour for Entire Intersection Begins at 17:00																					
17:00	1	1	2	0	4	10	65	1	0	76	0	3	2	0	5	0	34	7	0	41	126
17:15	4	1	3	0	8	13	52	5	0	70	4	1	7	0	12	7	34	6	0	47	137
17:30	3	0	1	1	5	15	60	7	0	82	2	1	6	0	9	7	29	9	1	46	142
17:45	7	0	0	0	7	5	50	4	0	59	1	1	3	0	5	7	40	4	0	51	122
Total Volume	15	2	6	1	24	43	227	17	0	287	7	6	18	0	31	21	137	26	1	185	527
% App. Total	62.5	8.3	25	4.2		15	79.1	5.9	0		22.6	19.4	58.1	0		11.4	74.1	14.1	0.5		
PHF	.536	.500	.500	.250	.750	.717	.873	.607	.000	.875	.438	.500	.643	.000	.646	.750	.856	.722	.250	.907	.928
Autos	15	2	6	1	24	43	224	17	0	284	7	6	18	0	31	21	137	26	1	185	524
% Autos	100	100	100	100	100	100	98.7	100	0	99.0	100	100	100	0	100	100	100	100	100	100	99.4
Heavy Vehicles	0	0	0	0	0	0	3	0	0	3	0	0	0	0	0	0	0	0	0	0	3
% Heavy Vehicles	0	0	0	0	0	0	1.3	0	0	1.0	0	0	0	0	0	0	0	0	0	0	0.6

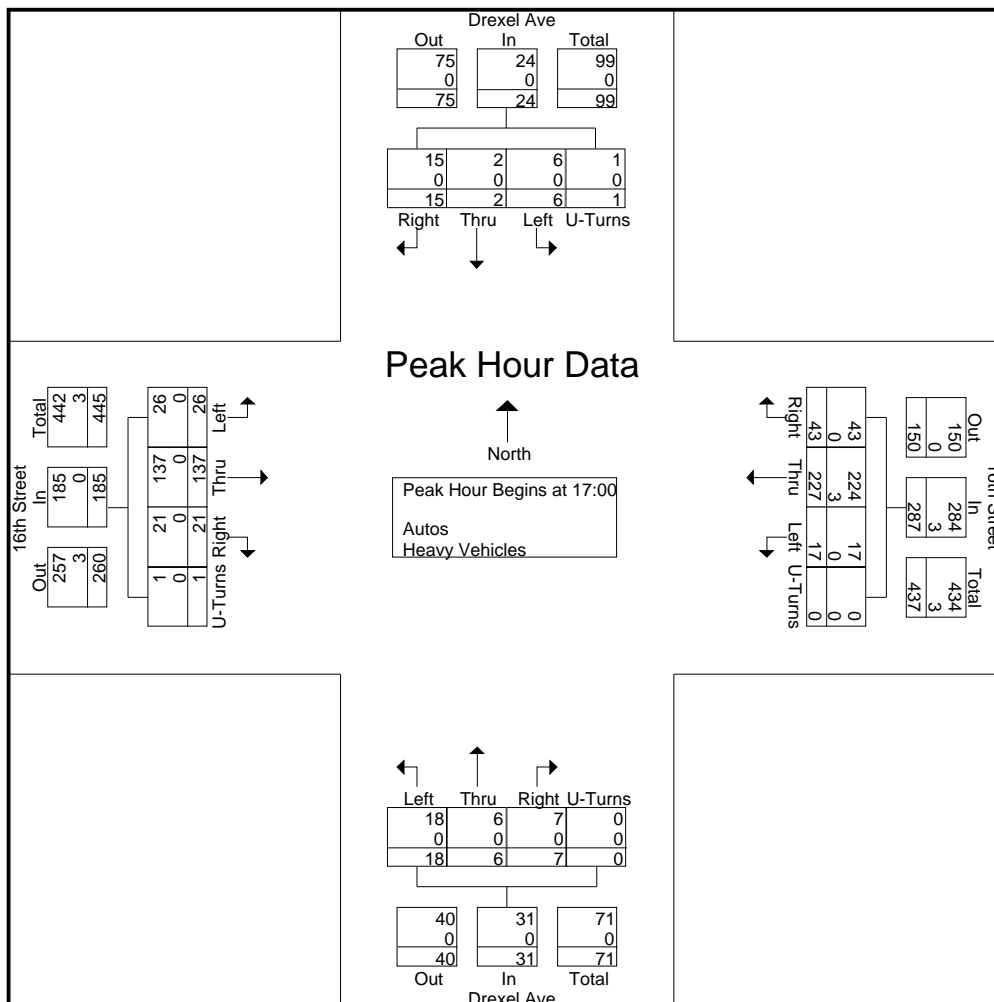

Traff Tech Engineering Inc.

File Name : 1-Drexel Ave & 16th St
 Site Code : 00000000
 Start Date : 6/12/2025
 Page No : 4

Start Time	Drexel Ave From North					16th Street From East					Drexel Ave From South					16th Street From West					Int. Total
	Right	Thru	Left	U-Turns	App. Total	Right	Thru	Left	U-Turns	App. Total	Right	Thru	Left	U-Turns	App. Total	Right	Thru	Left	U-Turns	App. Total	
Peak Hour Analysis From 07:00 to 08:45 - Peak 1 of 1																					
Peak Hour for Entire Intersection Begins at 08:00																					
08:00	0	1	0	0	1	0	23	0	0	23	4	1	0	0	5	2	22	0	0	24	53
08:15	1	0	0	0	1	7	25	1	0	33	3	0	4	1	8	0	28	1	0	29	71
08:30	1	0	1	0	2	1	27	2	0	30	1	0	0	1	1	43	1	0	45	78	
08:45	0	1	1	0	2	1	21	2	0	24	2	1	5	0	8	1	58	7	0	66	100
Total Volume	2	2	2	0	6	9	96	5	0	110	10	2	9	1	22	4	151	9	0	164	302
% App. Total	33.3	33.3	33.3	0		8.2	87.3	4.5	0		45.5	9.1	40.9	4.5		2.4	92.1	5.5	0		
PHF	.500	.500	.500	.000	.750	.321	.889	.625	.000	.833	.625	.500	.450	.250	.688	.500	.651	.321	.000	.621	.755
Autos	2	2	2	0	6	9	91	4	0	104	10	2	9	1	22	4	147	9	0	160	292
% Autos	100	100	100	0	100	100	94.8	80.0	0	94.5	100	100	100	100	100	100	97.4	100	0	97.6	96.7
Heavy Vehicles	0	0	0	0	0	0	5	1	0	6	0	0	0	0	0	0	4	0	0	4	10
% Heavy Vehicles	0	0	0	0	0	0	5.2	20.0	0	5.5	0	0	0	0	0	0	2.6	0	0	2.4	3.3

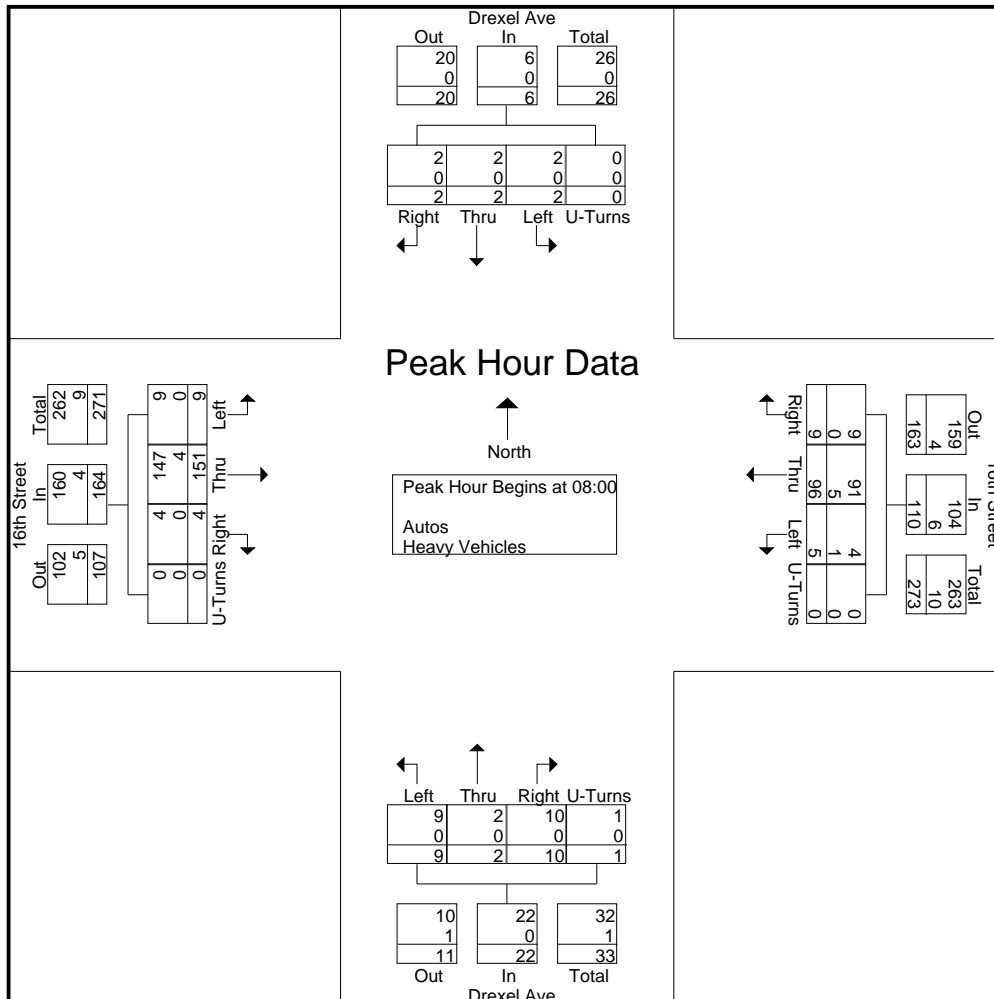

Traff Tech Engineering Inc.

File Name : 1-Drexel Ave & 16th St
 Site Code : 00000000
 Start Date : 6/12/2025
 Page No : 5

Start Time	Drexel Ave From North					16th Street From East					Drexel Ave From South					16th Street From West					Int. Total
	Right	Thru	Left	U-Turns	App. Total	Right	Thru	Left	U-Turns	App. Total	Right	Thru	Left	U-Turns	App. Total	Right	Thru	Left	U-Turns	App. Total	
Peak Hour Analysis From 16:00 to 17:45 - Peak 1 of 1																					
Peak Hour for Entire Intersection Begins at 17:00																					
17:00	1	1	2	0	4	10	65	1	0	76	0	3	2	0	5	0	34	7	0	41	126
17:15	4	1	3	0	8	13	52	5	0	70	4	1	7	0	12	7	34	6	0	47	137
17:30	3	0	1	1	5	15	60	7	0	82	2	1	6	0	9	7	29	9	1	46	142
17:45	7	0	0	0	7	5	50	4	0	59	1	1	3	0	5	7	40	4	0	51	122
Total Volume	15	2	6	1	24	43	227	17	0	287	7	6	18	0	31	21	137	26	1	185	527
% App. Total	62.5	8.3	25	4.2		15	79.1	5.9	0		22.6	19.4	58.1	0		11.4	74.1	14.1	0.5		
PHF	.536	.500	.500	.250	.750	.717	.873	.607	.000	.875	.438	.500	.643	.000	.646	.750	.856	.722	.250	.907	.928
Autos	15	2	6	1	24	43	224	17	0	284	7	6	18	0	31	21	137	26	1	185	524
% Autos	100	100	100	100	100	100	98.7	100	0	99.0	100	100	100	0	100	100	100	100	100	100	99.4
Heavy Vehicles	0	0	0	0	0	0	3	0	0	3	0	0	0	0	0	0	0	0	0	0	3
% Heavy Vehicles	0	0	0	0	0	0	1.3	0	0	1.0	0	0	0	0	0	0	0	0	0	0	0.6

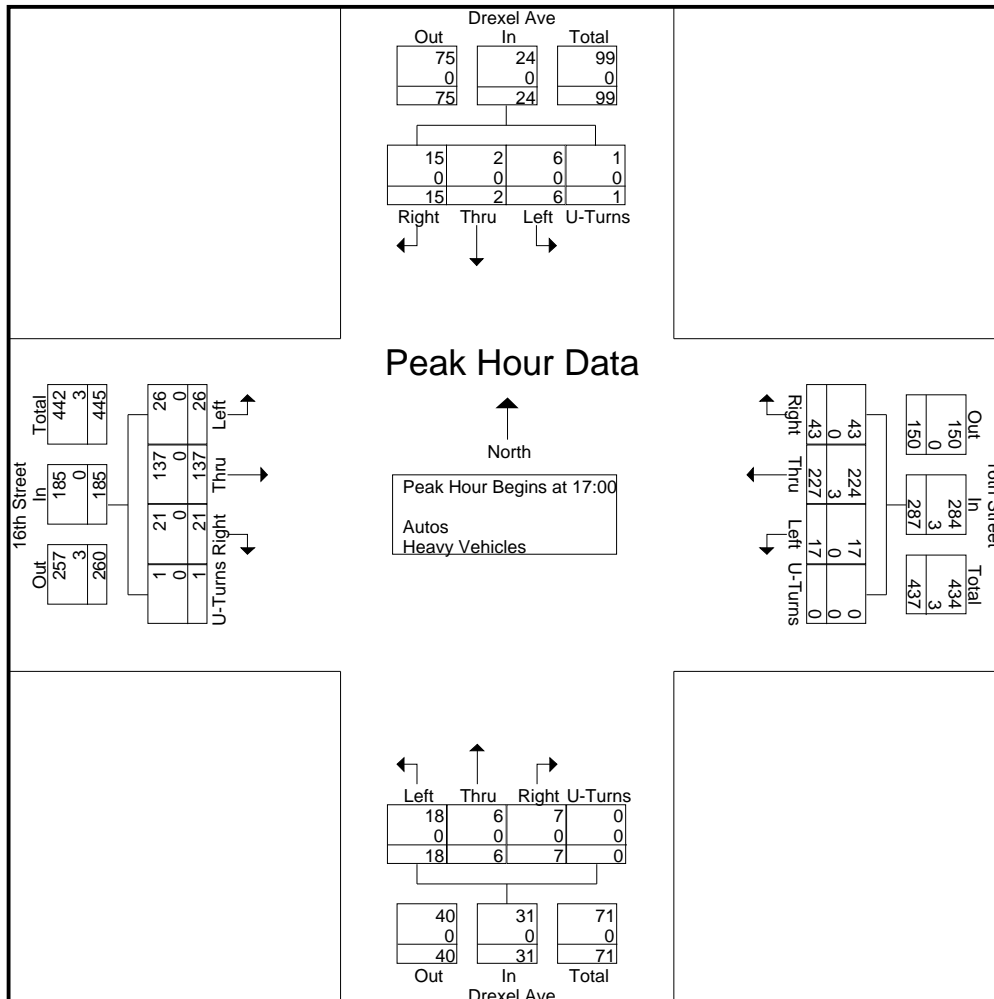

Traff Tech Engineering Inc.

File Name : 1-Drexel Ave & 16th St
 Site Code : 00000000
 Start Date : 6/12/2025
 Page No : 1

Groups Printed- Peds & Bikes

Start Time	Drexel Ave From North				16th Street From East				Drexel Ave From South				16th Street From West				Int. Total
07:00	0	0	0	2	0	0	0	3	0	0	0	6	0	0	0	5	16
07:15	0	0	0	2	0	0	0	0	1	0	0	4	0	0	0	2	9
07:30	0	0	0	2	0	0	0	4	0	0	0	7	0	0	0	0	13
07:45	0	0	0	8	0	0	0	4	0	0	0	5	0	0	0	3	20
Total	0	0	0	14	0	0	0	11	1	0	0	22	0	0	0	10	58
08:00	0	0	0	7	0	0	0	3	1	0	0	12	0	0	0	3	26
08:15	2	0	0	9	0	0	0	6	0	0	0	7	1	0	0	2	27
08:30	0	0	0	4	1	0	0	5	1	0	0	11	0	0	0	3	25
08:45	1	0	0	11	0	0	0	5	0	0	0	9	0	0	0	8	34
Total	3	0	0	31	1	0	0	19	2	0	0	39	1	0	0	16	112
*** BREAK ***																	
16:00	0	0	0	15	1	0	0	7	1	0	0	17	0	0	0	19	60
16:15	1	0	0	12	0	0	0	4	1	0	0	10	0	0	0	9	37
16:30	1	0	0	14	0	0	0	7	0	0	0	15	0	0	0	7	44
16:45	0	0	0	10	0	0	0	4	1	0	0	13	0	0	0	4	32
Total	2	0	0	51	1	0	0	22	3	0	0	55	0	0	0	39	173
17:00	0	0	0	18	2	0	0	9	1	0	0	11	0	0	0	13	54
17:15	0	0	0	14	0	0	0	5	0	0	0	11	0	0	0	18	48
17:30	1	0	0	14	0	0	0	9	0	0	0	4	0	0	0	11	39
17:45	0	0	0	14	1	0	0	7	1	0	0	9	0	0	0	10	42
Total	1	0	0	60	3	0	0	30	2	0	0	35	0	0	0	52	183
Grand Total	6	0	0	156	5	0	0	82	8	0	0	151	1	0	0	117	526
Apprch %	3.7	0	0	96.3	5.7	0	0	94.3	5	0	0	95	0.8	0	0	99.2	
Total %	1.1	0	0	29.7	1	0	0	15.6	1.5	0	0	28.7	0.2	0	0	22.2	

Traff Tech Engineering Inc.

File Name : 2-Garage & 16th St
 Site Code : 00000000
 Start Date : 6/12/2025
 Page No : 1

Groups Printed- Autos - Heavy Vehicles

Start Time	1601 Drexel - Public Parking From North					16th Street From East					From South					16th Street From West					Int. Total
	Right	Thru	Left	U-Turns	App. Total	Right	Thru	Left	U-Turns	App. Total	Right	Thru	Left	U-Turns	App. Total	Right	Thru	Left	U-Turns	App. Total	
07:00	0	0	0	0	0	0	18	0	0	18	0	0	0	0	0	0	20	7	0	27	45
07:15	0	0	0	0	0	0	18	0	0	18	0	0	0	0	0	0	27	5	0	32	50
07:30	0	0	0	0	0	2	28	0	0	30	0	0	0	0	0	0	16	7	0	23	53
07:45	0	0	1	0	1	2	24	0	0	26	0	0	0	0	0	0	25	7	0	32	59
Total	0	0	1	0	1	4	88	0	0	92	0	0	0	0	0	0	88	26	0	114	207
08:00	1	0	1	0	2	6	22	0	0	28	0	0	0	0	0	0	17	8	0	25	55
08:15	2	0	0	0	2	6	31	0	0	37	0	0	0	0	0	0	20	9	0	29	68
08:30	2	0	1	0	3	8	26	0	0	34	0	0	0	0	0	0	39	8	0	47	84
08:45	2	0	1	0	3	12	20	0	0	32	0	0	0	0	0	0	37	22	0	59	94
Total	7	0	3	0	10	32	99	0	0	131	0	0	0	0	0	0	113	47	0	160	301
*** BREAK ***																					
16:00	10	0	4	0	14	3	58	0	0	61	0	0	0	0	0	0	33	5	0	38	113
16:15	4	0	2	0	6	3	54	0	0	57	0	0	0	0	0	0	30	2	0	32	95
16:30	4	0	3	0	7	2	57	0	0	59	0	0	0	0	0	0	33	1	0	34	100
16:45	3	0	1	0	4	4	46	0	1	51	0	0	0	0	0	0	37	3	0	40	95
Total	21	0	10	0	31	12	215	0	1	228	0	0	0	0	0	0	133	11	0	144	403
17:00	7	0	11	0	18	5	67	0	0	72	0	0	0	0	0	0	34	3	0	37	127
17:15	7	0	3	0	10	3	65	0	0	68	0	0	0	0	0	0	37	3	0	40	118
17:30	12	0	0	0	12	6	69	0	0	75	0	0	0	0	0	0	30	2	1	33	120
17:45	9	0	4	0	13	0	49	0	0	49	0	0	0	0	0	0	40	3	0	43	105
Total	35	0	18	0	53	14	250	0	0	264	0	0	0	0	0	0	141	11	1	153	470
Grand Total	63	0	32	0	95	62	652	0	1	715	0	0	0	0	0	0	475	95	1	571	1381
Approch %	66.3	0	33.7	0		8.7	91.2	0	0.1		0	0	0	0		0	83.2	16.6	0.2		
Total %	4.6	0	2.3	0	6.9	4.5	47.2	0	0.1	51.8	0	0	0	0	0	0	34.4	6.9	0.1	41.3	
Autos	63	0	32	0	95	62	636	0	1	699	0	0	0	0	0	0	466	95	1	562	1356
% Autos	100	0	100	0	100	100	97.5	0	100	97.8	0	0	0	0	0	0	98.1	100	100	98.4	98.2
Heavy Vehicles	0	0	0	0	0	0	16	0	0	16	0	0	0	0	0	0	9	0	0	9	25
% Heavy Vehicles	0	0	0	0	0	0	2.5	0	0	2.2	0	0	0	0	0	0	1.9	0	0	1.6	1.8

Traff Tech Engineering Inc.

File Name : 2-Garage & 16th St

Site Code : 00000000

Start Date : 6/12/2025

Page No : 2

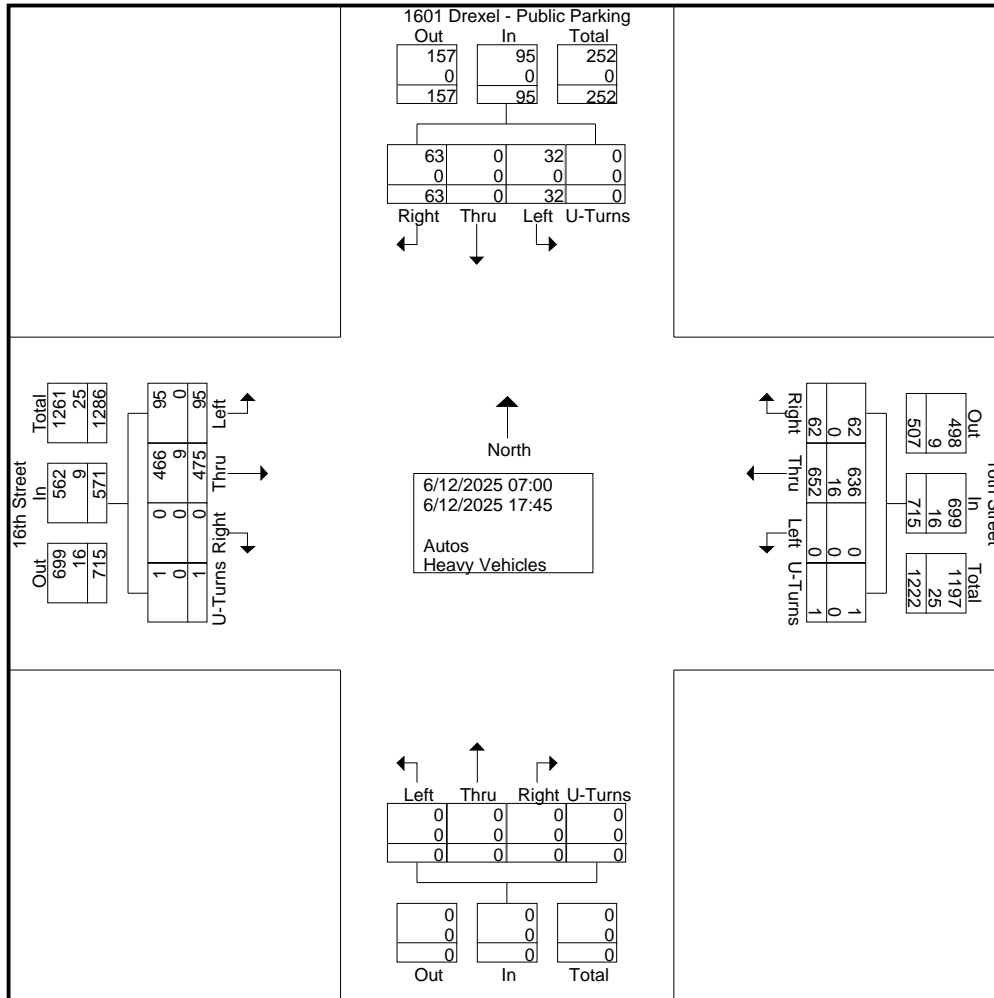

Traff Tech Engineering Inc.

File Name : 2-Garage & 16th St
 Site Code : 00000000
 Start Date : 6/12/2025
 Page No : 3

Start Time	1601 Drexel - Public Parking From North					16th Street From East					From South					16th Street From West					Int. Total
	Right	Thru	Left	U-Turns	App. Total	Right	Thru	Left	U-Turns	App. Total	Right	Thru	Left	U-Turns	App. Total	Right	Thru	Left	U-Turns	App. Total	
Peak Hour Analysis From 07:00 to 17:45 - Peak 1 of 1																					
Peak Hour for Entire Intersection Begins at 17:00																					
17:00	7	0	11	0	18	5	67	0	0	72	0	0	0	0	0	0	34	3	0	37	127
17:15	7	0	3	0	10	3	65	0	0	68	0	0	0	0	0	0	37	3	0	40	118
17:30	12	0	0	0	12	6	69	0	0	75	0	0	0	0	0	0	30	2	1	33	120
17:45	9	0	4	0	13	0	49	0	0	49	0	0	0	0	0	0	40	3	0	43	105
Total Volume	35	0	18	0	53	14	250	0	0	264	0	0	0	0	0	0	141	11	1	153	470
% App. Total	66	0	34	0		5.3	94.7	0	0		0	0	0	0	0	0	92.2	7.2	0.7		
PHF	.729	.000	.409	.000	.736	.583	.906	.000	.000	.880	.000	.000	.000	.000	.000	.000	.881	.917	.250	.890	.925
Autos	35	0	18	0	53	14	246	0	0	260	0	0	0	0	0	0	141	11	1	153	466
% Autos	100	0	100	0	100	100	98.4	0	0	98.5	0	0	0	0	0	0	100	100	100	100	99.1
Heavy Vehicles	0	0	0	0	0	0	4	0	0	4	0	0	0	0	0	0	0	0	0	0	4
% Heavy Vehicles	0	0	0	0	0	0	1.6	0	0	1.5	0	0	0	0	0	0	0	0	0	0	0.9

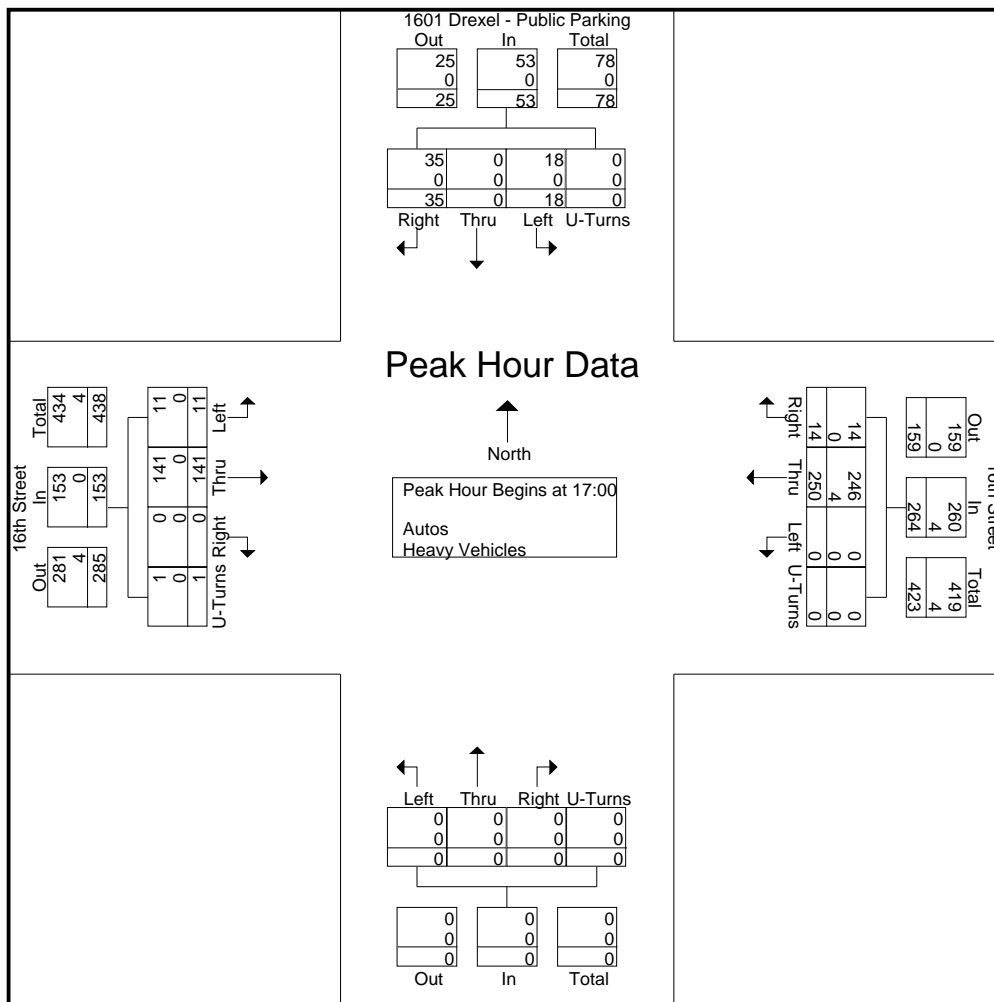

Traff Tech Engineering Inc.

File Name : 2-Garage & 16th St
 Site Code : 00000000
 Start Date : 6/12/2025
 Page No : 4

Start Time	1601 Drexel - Public Parking From North					16th Street From East					From South					16th Street From West					Int. Total
	Right	Thru	Left	U-Turns	App. Total	Right	Thru	Left	U-Turns	App. Total	Right	Thru	Left	U-Turns	App. Total	Right	Thru	Left	U-Turns	App. Total	
Peak Hour Analysis From 07:00 to 08:45 - Peak 1 of 1																					
Peak Hour for Entire Intersection Begins at 08:00																					
08:00	1	0	1	0	2	6	22	0	0	28	0	0	0	0	0	0	17	8	0	25	55
08:15	2	0	0	0	2	6	31	0	0	37	0	0	0	0	0	0	20	9	0	29	68
08:30	2	0	1	0	3	8	26	0	0	34	0	0	0	0	0	0	39	8	0	47	84
08:45	2	0	1	0	3	12	20	0	0	32	0	0	0	0	0	0	37	22	0	59	94
Total Volume	7	0	3	0	10	32	99	0	0	131	0	0	0	0	0	0	113	47	0	160	301
% App. Total	70	0	30	0		24.4	75.6	0	0		0	0	0	0		0	70.6	29.4	0		
PHF	.875	.000	.750	.000	.833	.667	.798	.000	.000	.885	.000	.000	.000	.000	.000	.000	.724	.534	.000	.678	.801
Autos	7	0	3	0	10	32	93	0	0	125	0	0	0	0	0	0	109	47	0	156	291
% Autos	100	0	100	0	100	100	93.9	0	0	95.4	0	0	0	0	0	0	96.5	100	0	97.5	96.7
Heavy Vehicles	0	0	0	0	0	0	6	0	0	6	0	0	0	0	0	0	4	0	0	4	10
% Heavy Vehicles	0	0	0	0	0	0	6.1	0	0	4.6	0	0	0	0	0	0	3.5	0	0	2.5	3.3

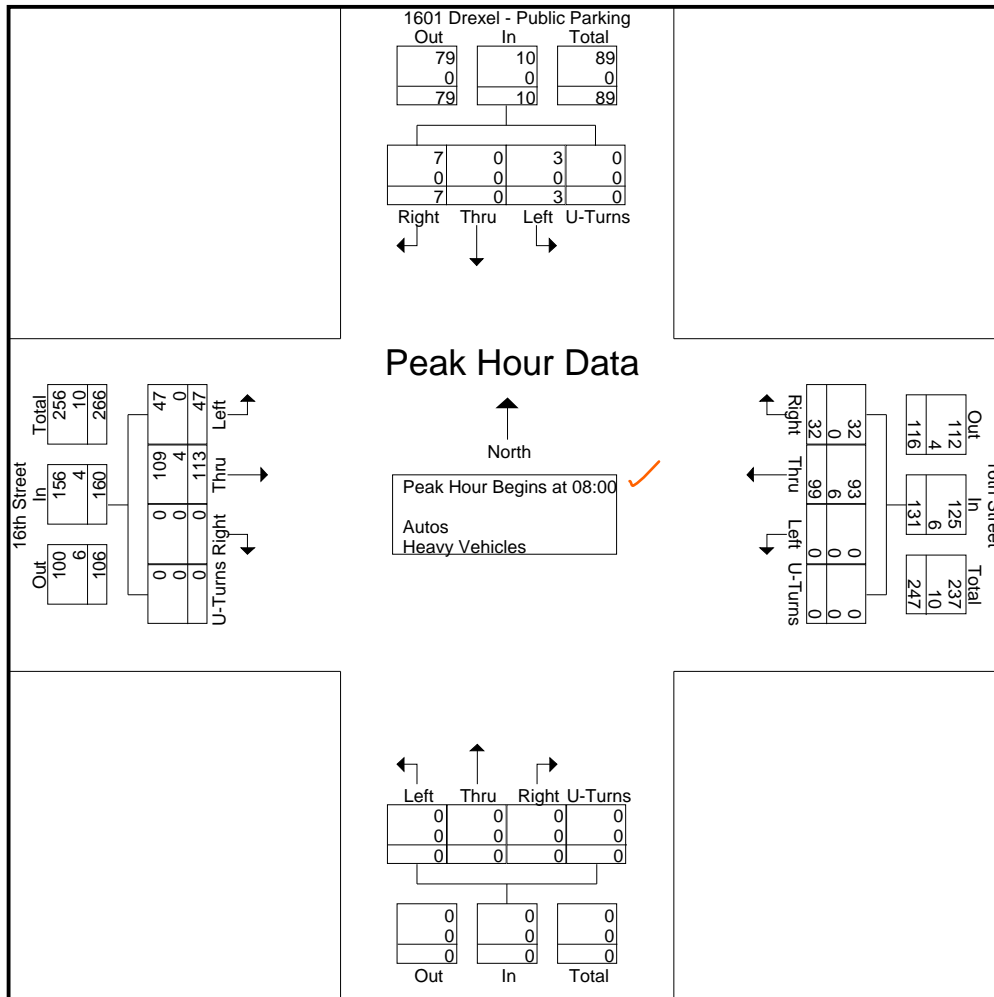

Traff Tech Engineering Inc.

File Name : 2-Garage & 16th St
 Site Code : 00000000
 Start Date : 6/12/2025
 Page No : 5

Start Time	1601 Drexel - Public Parking From North					16th Street From East					From South					16th Street From West					Int. Total
	Right	Thru	Left	U-Turns	App. Total	Right	Thru	Left	U-Turns	App. Total	Right	Thru	Left	U-Turns	App. Total	Right	Thru	Left	U-Turns	App. Total	
Peak Hour Analysis From 16:00 to 17:45 - Peak 1 of 1																					
Peak Hour for Entire Intersection Begins at 17:00																					
17:00	7	0	11	0	18	5	67	0	0	72	0	0	0	0	0	0	34	3	0	37	127
17:15	7	0	3	0	10	3	65	0	0	68	0	0	0	0	0	0	37	3	0	40	118
17:30	12	0	0	0	12	6	69	0	0	75	0	0	0	0	0	0	30	2	1	33	120
17:45	9	0	4	0	13	0	49	0	0	49	0	0	0	0	0	0	40	3	0	43	105
Total Volume	35	0	18	0	53	14	250	0	0	264	0	0	0	0	0	0	141	11	1	153	470
% App. Total	66	0	34	0		5.3	94.7	0	0		0	0	0	0	0	0	92.2	7.2	0.7		
PHF	.729	.000	.409	.000	.736	.583	.906	.000	.000	.880	.000	.000	.000	.000	.000	.000	.881	.917	.250	.890	.925
Autos	35	0	18	0	53	14	246	0	0	260	0	0	0	0	0	0	141	11	1	153	466
% Autos	100	0	100	0	100	100	98.4	0	0	98.5	0	0	0	0	0	0	100	100	100	100	99.1
Heavy Vehicles	0	0	0	0	0	0	4	0	0	4	0	0	0	0	0	0	0	0	0	0	4
% Heavy Vehicles	0	0	0	0	0	0	1.6	0	0	1.5	0	0	0	0	0	0	0	0	0	0	0.9

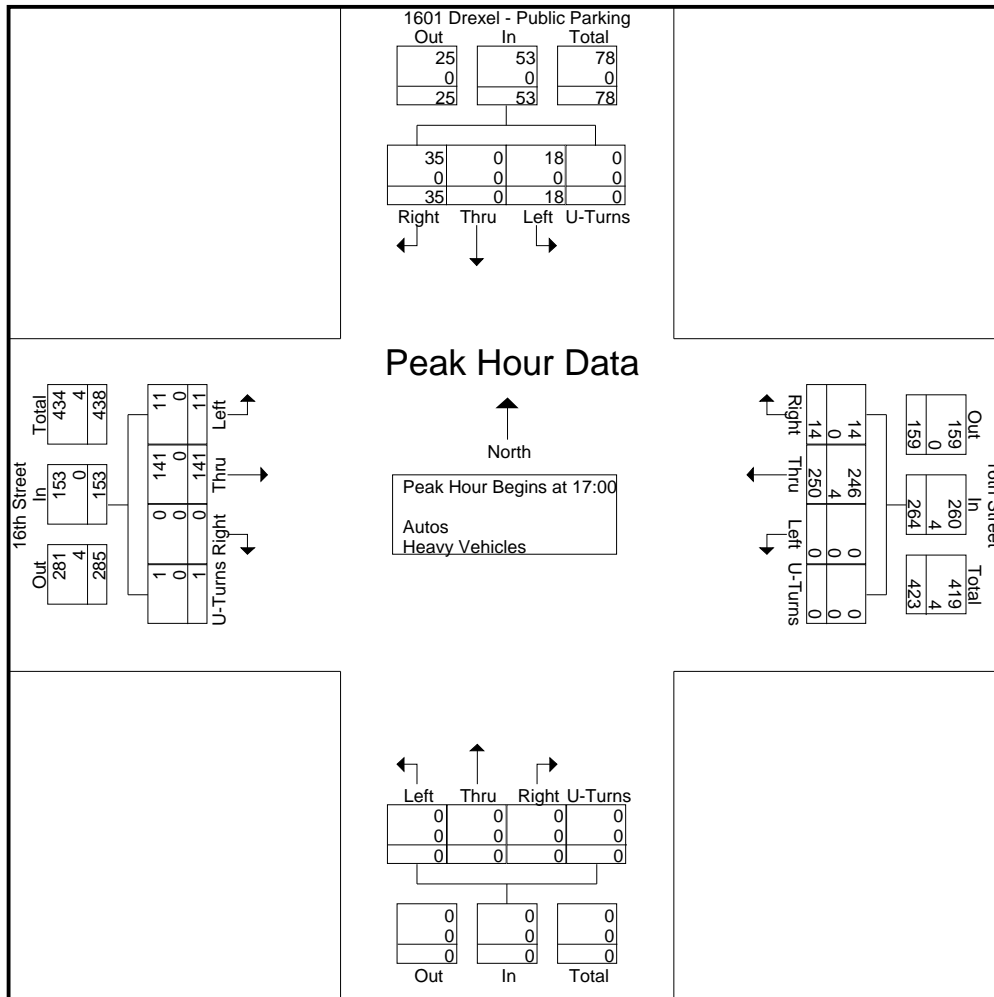

Traff Tech Engineering Inc.

File Name : 3-Washington Ave & 16th St
 Site Code : 00000000
 Start Date : 6/12/2025
 Page No : 1

Groups Printed- Autos - Heavy Vehicles

Start Time	Washington Ave From North					16th Street From East					Washington Ave From South					16th Street From West					Int. Total
	Right	Thru	Left	U-Turns	App. Total	Right	Thru	Left	U-Turns	App. Total	Right	Thru	Left	U-Turns	App. Total	Right	Thru	Left	U-Turns	App. Total	
07:00	7	33	6	1	47	5	10	9	0	24	5	23	2	1	31	4	14	2	0	20	122
07:15	9	55	7	1	72	9	7	3	0	19	3	30	2	1	36	2	23	2	0	27	154
07:30	11	41	8	2	62	10	18	6	0	34	10	27	1	0	38	3	9	4	0	16	150
07:45	10	59	9	2	80	4	12	5	0	21	9	37	5	0	51	2	17	5	0	24	176
Total	37	188	30	6	261	28	47	23	0	98	27	117	10	2	156	11	63	13	0	87	602
08:00	14	60	12	1	87	5	11	5	0	21	7	29	4	1	41	3	9	1	0	13	162
08:15	19	65	7	1	92	7	13	5	0	25	7	45	5	1	58	3	15	3	0	21	196
08:30	18	67	12	1	98	9	11	6	0	26	5	41	9	1	56	9	18	15	1	43	223
08:45	17	93	15	1	126	15	10	7	0	32	12	61	7	1	81	8	21	7	0	36	275
Total	68	285	46	4	403	36	45	23	0	104	31	176	25	4	236	23	63	26	1	113	856
*** BREAK ***																					
16:00	21	87	13	0	121	25	23	10	0	58	18	121	14	3	156	8	17	15	0	40	375
16:15	32	95	18	0	145	24	17	5	0	46	5	134	9	1	149	1	14	13	0	28	368
16:30	27	118	10	3	158	22	17	8	0	47	18	109	17	4	148	4	17	14	0	35	388
16:45	27	79	13	1	120	21	14	10	0	45	20	111	8	3	142	8	16	18	0	42	349
Total	107	379	54	4	544	92	71	33	0	196	61	475	48	11	595	21	64	60	0	145	1480
17:00	35	103	18	0	156	44	33	17	0	94	10	127	6	2	145	17	22	9	0	48	443
17:15	43	126	8	1	178	19	21	8	0	48	10	151	7	2	170	10	20	10	0	40	436
17:30	37	146	13	1	197	18	28	10	0	56	16	120	6	3	145	2	19	7	0	28	426
17:45	18	152	17	2	189	21	17	12	0	50	11	122	12	5	150	12	20	9	0	41	430
Total	133	527	56	4	720	102	99	47	0	248	47	520	31	12	610	41	81	35	0	157	1735
Grand Total	345	1379	186	18	1928	258	262	126	0	646	166	1288	114	29	1597	96	271	134	1	502	4673
Apprch %	17.9	71.5	9.6	0.9		39.9	40.6	19.5	0		10.4	80.7	7.1	1.8		19.1	54	26.7	0.2		
Total %	7.4	29.5	4	0.4	41.3	5.5	5.6	2.7	0	13.8	3.6	27.6	2.4	0.6	34.2	2.1	5.8	2.9	0	10.7	
Autos	337	1313	180	17	1847	258	256	126	0	640	163	1231	112	29	1535	93	269	131	1	494	4516
% Autos	97.7	95.2	96.8	94.4	95.8	100	97.7	100	0	99.1	98.2	95.6	98.2	100	96.1	96.9	99.3	97.8	100	98.4	96.6
Heavy Vehicles	8	66	6	1	81	0	6	0	0	6	3	57	2	0	62	3	2	3	0	8	157
% Heavy Vehicles	2.3	4.8	3.2	5.6	4.2	0	2.3	0	0	0.9	1.8	4.4	1.8	0	3.9	3.1	0.7	2.2	0	1.6	3.4

Traff Tech Engineering Inc.

File Name : 3-Washington Ave & 16th St
 Site Code : 00000000
 Start Date : 6/12/2025
 Page No : 2

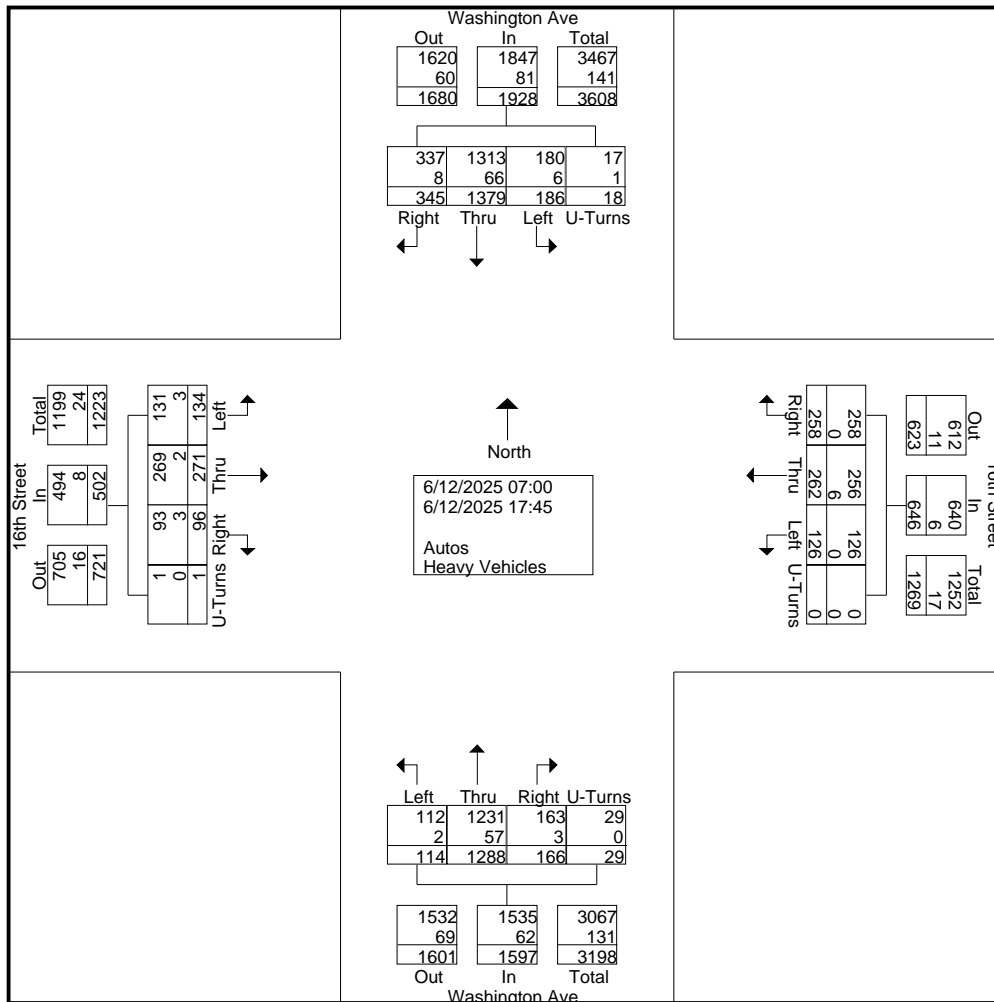

Traff Tech Engineering Inc.

File Name : 3-Washington Ave & 16th St
 Site Code : 00000000
 Start Date : 6/12/2025
 Page No : 3

Start Time	Washington Ave From North					16th Street From East					Washington Ave From South					16th Street From West					Int. Total
	Right	Thru	Left	U-Turns	App. Total	Right	Thru	Left	U-Turns	App. Total	Right	Thru	Left	U-Turns	App. Total	Right	Thru	Left	U-Turns	App. Total	
Peak Hour Analysis From 07:00 to 17:45 - Peak 1 of 1																					
Peak Hour for Entire Intersection Begins at 17:00																					
17:00	35	103	18	0	156	44	33	17	0	94	10	127	6	2	145	17	22	9	0	48	443
17:15	43	126	8	1	178	19	21	8	0	48	10	151	7	2	170	10	20	10	0	40	436
17:30	37	146	13	1	197	18	28	10	0	56	16	120	6	3	145	2	19	7	0	28	426
17:45	18	152	17	2	189	21	17	12	0	50	11	122	12	5	150	12	20	9	0	41	430
Total Volume	133	527	56	4	720	102	99	47	0	248	47	520	31	12	610	41	81	35	0	157	1735
% App. Total	18.5	73.2	7.8	0.6		41.1	39.9	19	0		7.7	85.2	5.1	2		26.1	51.6	22.3	0		
PHF	.773	.867	.778	.500	.914	.580	.750	.691	.000	.660	.734	.861	.646	.600	.897	.603	.920	.875	.000	.818	.979
Autos	129	513	56	4	702	102	99	47	0	248	47	504	31	12	594	41	81	35	0	157	1701
% Autos	97.0	97.3	100	100	97.5	100	100	100	0	100	100	96.9	100	100	97.4	100	100	100	0	100	98.0
Heavy Vehicles	4	14	0	0	18	0	0	0	0	0	0	16	0	0	16	0	0	0	0	0	34
% Heavy Vehicles	3.0	2.7	0	0	2.5	0	0	0	0	0	0	3.1	0	0	2.6	0	0	0	0	0	2.0

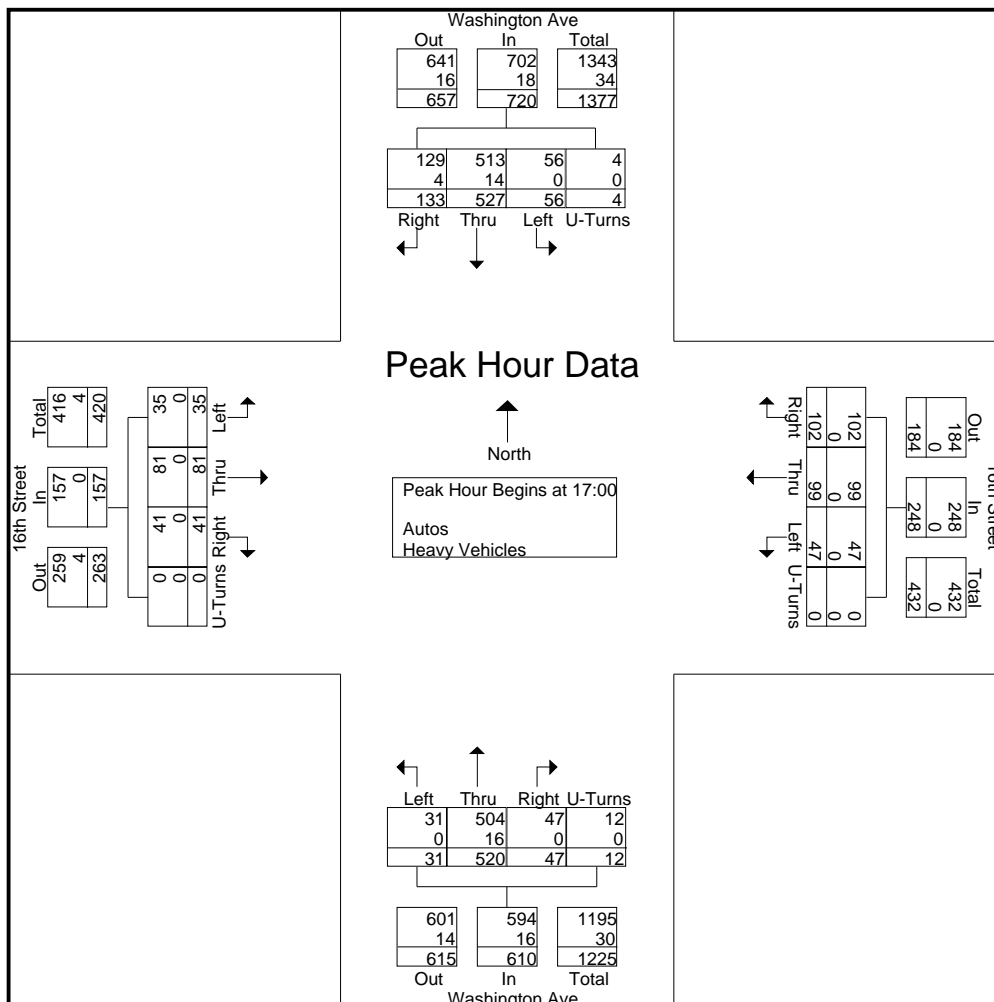

Traff Tech Engineering Inc.

File Name : 3-Washington Ave & 16th St
 Site Code : 00000000
 Start Date : 6/12/2025
 Page No : 4

Start Time	Washington Ave From North					16th Street From East					Washington Ave From South					16th Street From West					Int. Total
	Right	Thru	Left	U-Turns	App. Total	Right	Thru	Left	U-Turns	App. Total	Right	Thru	Left	U-Turns	App. Total	Right	Thru	Left	U-Turns	App. Total	
Peak Hour Analysis From 07:00 to 08:45 - Peak 1 of 1																					
Peak Hour for Entire Intersection Begins at 08:00																					
08:00	14	60	12	1	87	5	11	5	0	21	7	29	4	1	41	3	9	1	0	13	162
08:15	19	65	7	1	92	7	13	5	0	25	7	45	5	1	58	3	15	3	0	21	196
08:30	18	67	12	1	98	9	11	6	0	26	5	41	9	1	56	9	18	15	1	43	223
08:45	17	93	15	1	126	15	10	7	0	32	12	61	7	1	81	8	21	7	0	36	275
Total Volume	68	285	46	4	403	36	45	23	0	104	31	176	25	4	236	23	63	26	1	113	856
% App. Total	16.9	70.7	11.4	1		34.6	43.3	22.1	0		13.1	74.6	10.6	1.7		20.4	55.8	23	0.9		
PHF	.895	.766	.767	1.0	.800	.600	.865	.821	.000	.813	.646	.721	.694	1.0	.728	.639	.750	.433	.250	.657	.778
Autos	66	262	44	4	376	36	42	23	0	101	30	161	24	4	219	22	62	24	1	109	805
% Autos	97.1	91.9	95.7	100	93.3	100	93.3	100	0	97.1	96.8	91.5	96.0	100	92.8	95.7	98.4	92.3	100	96.5	94.0
Heavy Vehicles	2	23	2	0	27	0	3	0	0	3	1	15	1	0	17	1	1	2	0	4	51
% Heavy Vehicles	2.9	8.1	4.3	0	6.7	0	6.7	0	0	2.9	3.2	8.5	4.0	0	7.2	4.3	1.6	7.7	0	3.5	6.0

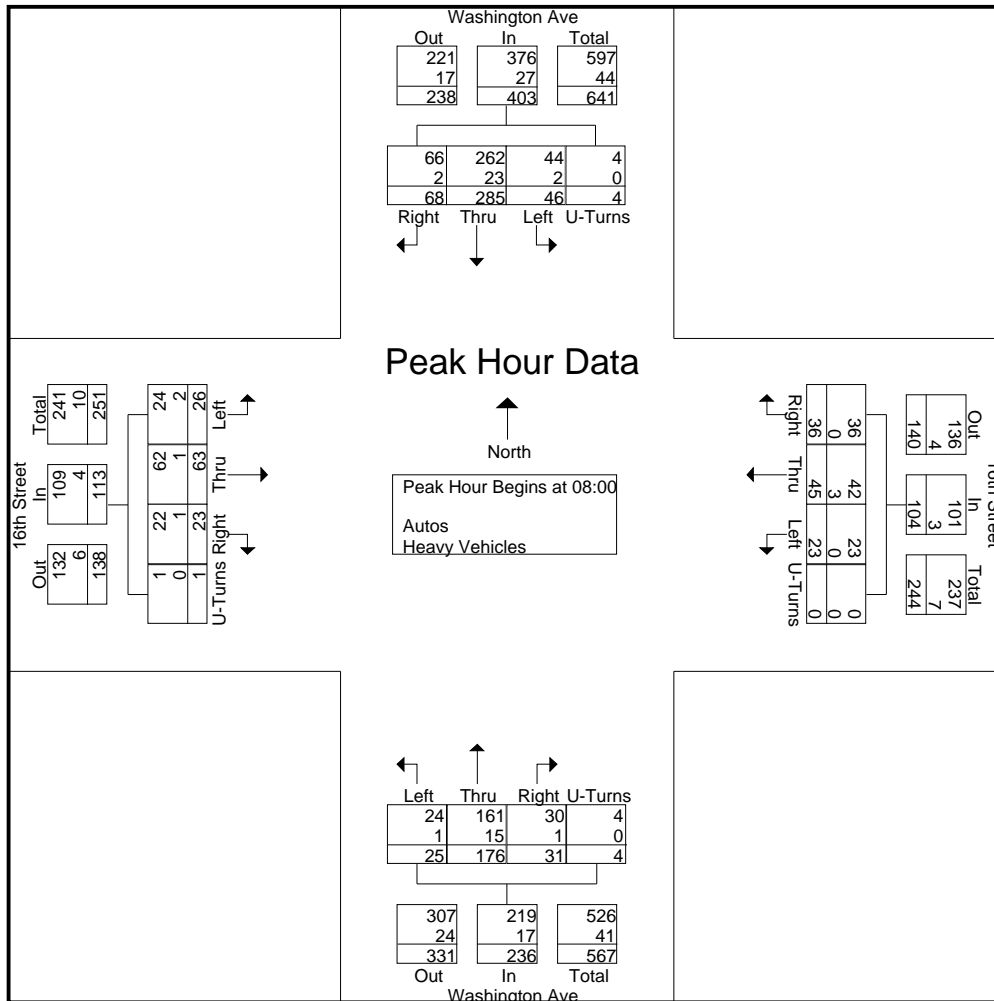

Traff Tech Engineering Inc.

File Name : 3-Washington Ave & 16th St
 Site Code : 00000000
 Start Date : 6/12/2025
 Page No : 5

Start Time	Washington Ave From North					16th Street From East					Washington Ave From South					16th Street From West					Int. Total
	Right	Thru	Left	U-Turns	App. Total	Right	Thru	Left	U-Turns	App. Total	Right	Thru	Left	U-Turns	App. Total	Right	Thru	Left	U-Turns	App. Total	
Peak Hour Analysis From 16:00 to 17:45 - Peak 1 of 1																					
Peak Hour for Entire Intersection Begins at 17:00																					
17:00	35	103	18	0	156	44	33	17	0	94	10	127	6	2	145	17	22	9	0	48	443
17:15	43	126	8	1	178	19	21	8	0	48	10	151	7	2	170	10	20	10	0	40	436
17:30	37	146	13	1	197	18	28	10	0	56	16	120	6	3	145	2	19	7	0	28	426
17:45	18	152	17	2	189	21	17	12	0	50	11	122	12	5	150	12	20	9	0	41	430
Total Volume	133	527	56	4	720	102	99	47	0	248	47	520	31	12	610	41	81	35	0	157	1735
% App. Total	18.5	73.2	7.8	0.6		41.1	39.9	19	0		7.7	85.2	5.1	2		26.1	51.6	22.3	0		
PHF	.773	.867	.778	.500	.914	.580	.750	.691	.000	.660	.734	.861	.646	.600	.897	.603	.920	.875	.000	.818	.979
Autos	129	513	56	4	702	102	99	47	0	248	47	504	31	12	594	41	81	35	0	157	1701
% Autos	97.0	97.3	100	100	97.5	100	100	100	0	100	100	96.9	100	100	97.4	100	100	100	0	100	98.0
Heavy Vehicles	4	14	0	0	18	0	0	0	0	0	0	16	0	0	16	0	0	0	0	0	34
% Heavy Vehicles	3.0	2.7	0	0	2.5	0	0	0	0	0	0	3.1	0	0	2.6	0	0	0	0	0	2.0

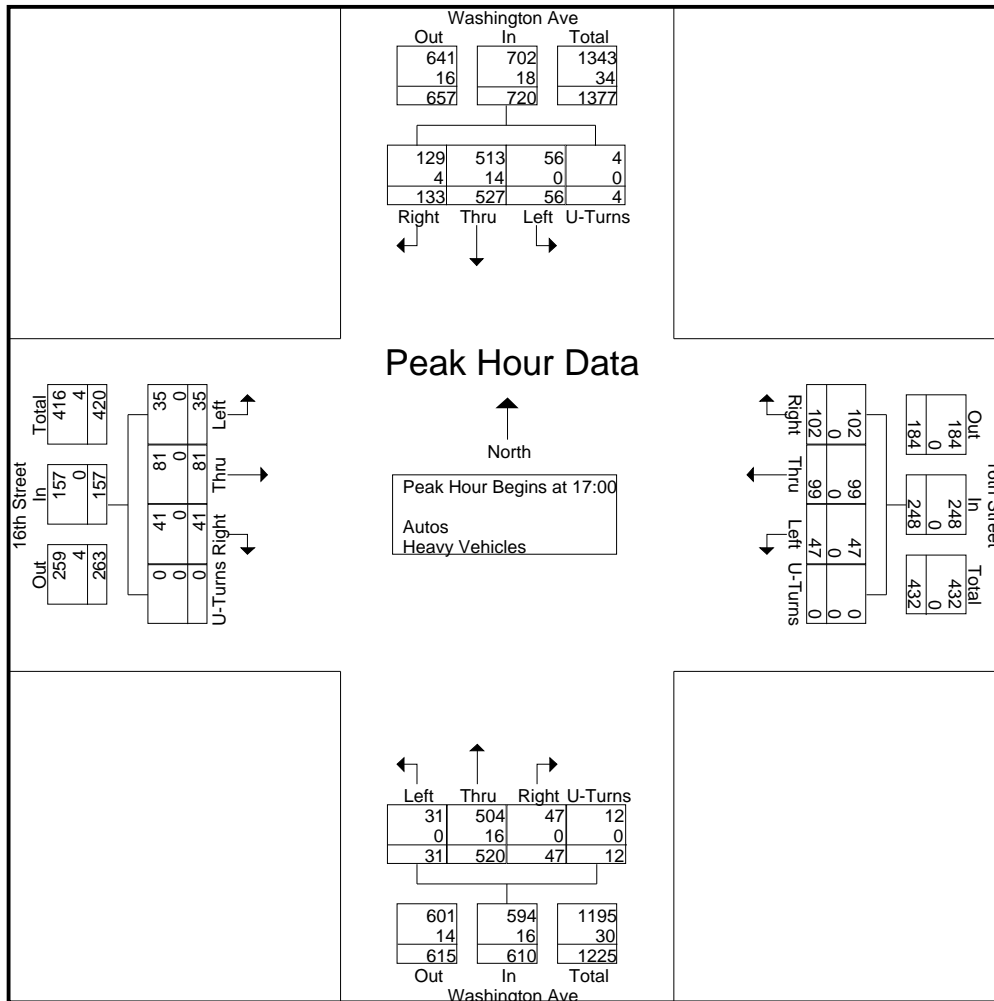

Traff Tech Engineering Inc.

File Name : 3-Washington Ave & 16th St
 Site Code : 00000000
 Start Date : 6/12/2025
 Page No : 1

Groups Printed- Peds & Bikes

Start Time	Washington Ave From North				16th Street From East				Washington Ave From South				16th Street From West				Int. Total
07:00	1	0	0	2	2	0	0	11	1	0	0	6	1	0	0	7	31
07:15	0	0	0	2	0	0	0	10	2	0	0	3	0	0	0	5	22
07:30	2	0	0	7	0	0	0	19	2	0	0	6	4	0	0	10	50
07:45	1	0	0	15	2	0	0	18	2	0	0	5	1	0	0	4	48
Total	4	0	0	26	4	0	0	58	7	0	0	20	6	0	0	26	151
08:00	0	0	0	9	1	0	0	21	0	0	0	6	0	0	0	15	52
08:15	0	0	0	20	2	0	0	23	0	0	0	4	0	0	0	9	58
08:30	0	0	0	24	0	0	0	24	0	0	0	12	1	0	0	38	99
08:45	0	0	0	47	4	0	0	26	1	0	0	4	2	0	0	28	112
Total	0	0	0	100	7	0	0	94	1	0	0	26	3	0	0	90	321
*** BREAK ***																	
16:00	6	0	0	33	7	0	0	21	4	0	0	15	3	0	0	90	179
16:15	2	0	0	33	0	0	0	52	1	0	0	14	3	0	0	68	173
16:30	1	0	0	13	1	0	0	34	1	0	0	11	3	0	0	78	142
16:45	1	0	0	17	2	0	0	28	3	0	0	17	4	0	0	77	149
Total	10	0	0	96	10	0	0	135	9	0	0	57	13	0	0	313	643
17:00	1	0	0	28	2	0	0	78	6	0	0	34	6	0	0	116	271
17:15	3	0	0	20	3	0	0	53	0	0	0	27	2	0	0	109	217
17:30	0	0	0	38	4	0	0	43	1	0	0	12	6	0	0	152	256
17:45	5	0	0	36	0	0	0	52	3	0	0	14	1	0	0	83	194
Total	9	0	0	122	9	0	0	226	10	0	0	87	15	0	0	460	938
Grand Total	23	0	0	344	30	0	0	513	27	0	0	190	37	0	0	889	2053
Apprch %	6.3	0	0	93.7	5.5	0	0	94.5	12.4	0	0	87.6	4	0	0	96	
Total %	1.1	0	0	16.8	1.5	0	0	25	1.3	0	0	9.3	1.8	0	0	43.3	

Traff Tech Engineering Inc.

File Name : 4-Collins Ave & 16th St

Site Code : 00000000

Start Date : 6/12/2025

Page No : 1

Groups Printed- Autos - Heavy Vehicles

Start Time	Collins Ave From North					16th Street From East					Collins Ave From South					16th Street From West					Int. Total
	Right	Thru	Left	U-Turns	App. Total	Right	Thru	Left	U-Turns	App. Total	Right	Thru	Left	U-Turns	App. Total	Right	Thru	Left	U-Turns	App. Total	
07:00	16	71	2	0	89	1	1	0	0	2	0	40	9	0	49	8	0	14	0	22	162
07:15	18	53	2	0	73	0	1	1	0	2	0	56	6	0	62	7	0	12	1	20	157
07:30	24	87	1	0	112	1	0	0	0	1	1	45	10	0	56	6	0	18	0	24	193
07:45	21	73	3	0	97	1	2	0	0	3	0	57	6	0	63	9	2	13	0	24	187
Total	79	284	8	0	371	3	4	1	0	8	1	198	31	0	230	30	2	57	1	90	699
08:00	26	86	2	0	114	1	1	0	0	2	0	71	8	0	79	9	0	8	0	17	212
08:15	24	99	2	0	125	2	1	0	0	3	3	60	8	0	71	13	0	9	0	22	221
08:30	19	89	3	0	111	1	2	1	0	4	2	63	4	0	69	10	1	11	0	22	206
08:45	27	68	4	0	99	4	1	1	0	6	0	75	3	0	78	13	2	17	0	32	215
Total	96	342	11	0	449	8	5	2	0	15	5	269	23	0	297	45	3	45	0	93	854

*** BREAK ***

16:00	35	100	4	0	139	4	1	3	0	8	5	128	12	0	145	8	3	32	0	43	335
16:15	19	100	6	0	125	1	2	2	0	5	2	109	14	0	125	15	2	12	0	29	284
16:30	19	103	9	0	131	3	4	3	0	10	4	96	6	0	106	19	2	28	0	49	296
16:45	25	114	5	0	144	2	3	1	0	6	1	99	10	0	110	18	2	26	0	46	306
Total	98	417	24	0	539	10	10	9	0	29	12	432	42	0	486	60	9	98	0	167	1221
17:00	41	92	3	0	136	2	0	2	0	4	2	109	14	0	125	21	1	28	0	50	315
17:15	21	131	2	0	154	2	2	0	0	4	1	94	14	0	109	8	1	26	0	35	302
17:30	28	111	6	0	145	5	0	3	0	8	5	87	19	0	111	13	4	33	0	50	314
17:45	34	113	4	0	151	1	4	1	0	6	1	80	4	0	85	15	5	26	0	46	288
Total	124	447	15	0	586	10	6	6	0	22	9	370	51	0	430	57	11	113	0	181	1219
Grand Total	397	1490	58	0	1945	31	25	18	0	74	27	1269	147	0	1443	192	25	313	1	531	3993
Apprch %	20.4	76.6	3	0		41.9	33.8	24.3	0		1.9	87.9	10.2	0		36.2	4.7	58.9	0.2		
Total %	9.9	37.3	1.5	0	48.7	0.8	0.6	0.5	0	1.9	0.7	31.8	3.7	0	36.1	4.8	0.6	7.8	0	13.3	
Autos	389	1466	58	0	1913	31	25	18	0	74	27	1239	146	0	1412	188	25	306	1	520	3919
% Autos	98	98.4	100	0	98.4	100	100	100	0	100	100	97.6	99.3	0	97.9	97.9	100	97.8	100	97.9	98.1
Heavy Vehicles	8	24	0	0	32	0	0	0	0	0	0	30	1	0	31	4	0	7	0	11	74
% Heavy Vehicles	2	1.6	0	0	1.6	0	0	0	0	0	0	2.4	0.7	0	2.1	2.1	0	2.2	0	2.1	1.9

Traff Tech Engineering Inc.

File Name : 4-Collins Ave & 16th St

Site Code : 00000000

Start Date : 6/12/2025

Page No : 2

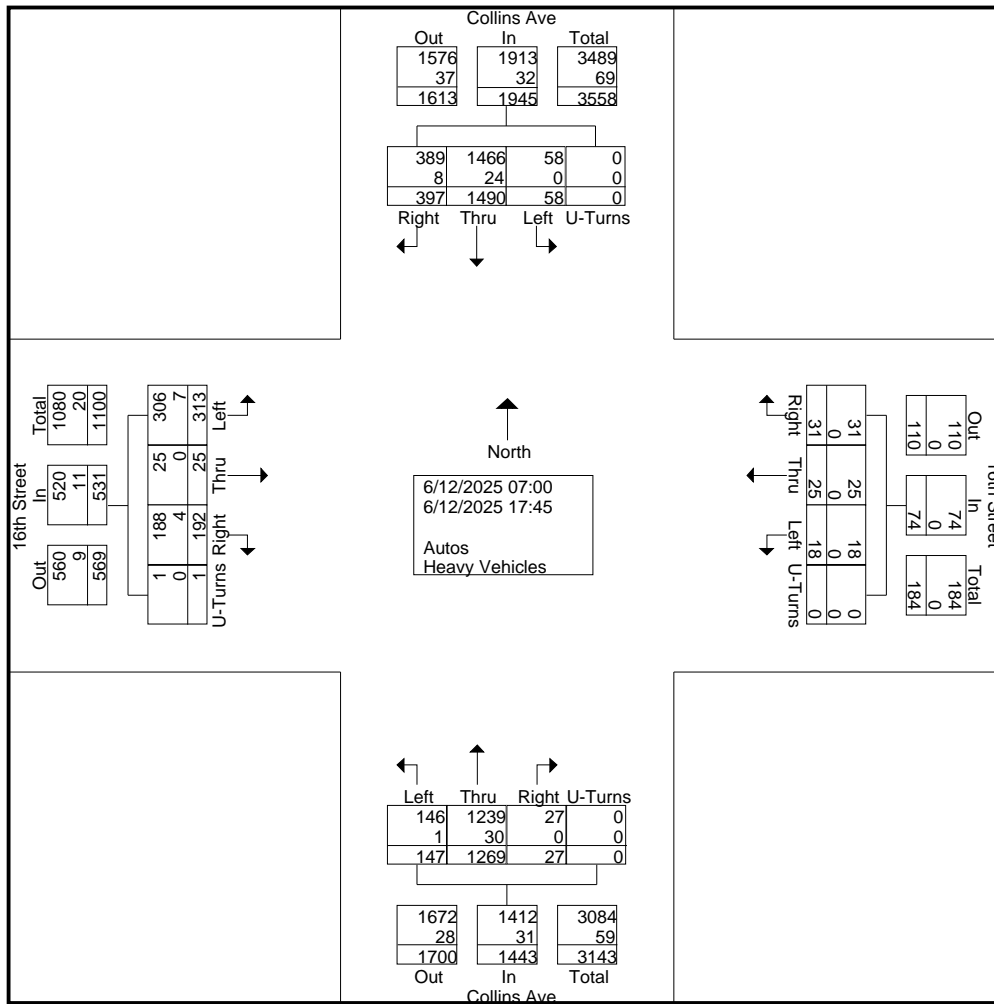

Traff Tech Engineering Inc.

File Name : 4-Collins Ave & 16th St
 Site Code : 00000000
 Start Date : 6/12/2025
 Page No : 3

Start Time	Collins Ave From North					16th Street From East					Collins Ave From South					16th Street From West					Int. Total
	Right	Thru	Left	U-Turns	App. Total	Right	Thru	Left	U-Turns	App. Total	Right	Thru	Left	U-Turns	App. Total	Right	Thru	Left	U-Turns	App. Total	
Peak Hour Analysis From 07:00 to 17:45 - Peak 1 of 1																					
Peak Hour for Entire Intersection Begins at 16:45																					
16:45	25	114	5	0	144	2	3	1	0	6	1	99	10	0	110	18	2	26	0	46	306
17:00	41	92	3	0	136	2	0	2	0	4	2	109	14	0	125	21	1	28	0	50	315
17:15	21	131	2	0	154	2	2	0	0	4	1	94	14	0	109	8	1	26	0	35	302
17:30	28	111	6	0	145	5	0	3	0	8	5	87	19	0	111	13	4	33	0	50	314
Total Volume	115	448	16	0	579	11	5	6	0	22	9	389	57	0	455	60	8	113	0	181	1237
% App. Total	19.9	77.4	2.8	0		50	22.7	27.3	0		2	85.5	12.5	0		33.1	4.4	62.4	0		
PHF	.701	.855	.667	.000	.940	.550	.417	.500	.000	.688	.450	.892	.750	.000	.910	.714	.500	.856	.000	.905	.982
Autos	115	447	16	0	578	11	5	6	0	22	9	385	57	0	451	60	8	113	0	181	1232
% Autos	100	99.8	100	0	99.8	100	100	100	0	100	100	99.0	100	0	99.1	100	100	100	0	100	99.6
Heavy Vehicles	0	1	0	0	1	0	0	0	0	0	0	4	0	0	4	0	0	0	0	0	5
% Heavy Vehicles	0	0.2	0	0	0.2	0	0	0	0	0	0	1.0	0	0	0.9	0	0	0	0	0	0.4

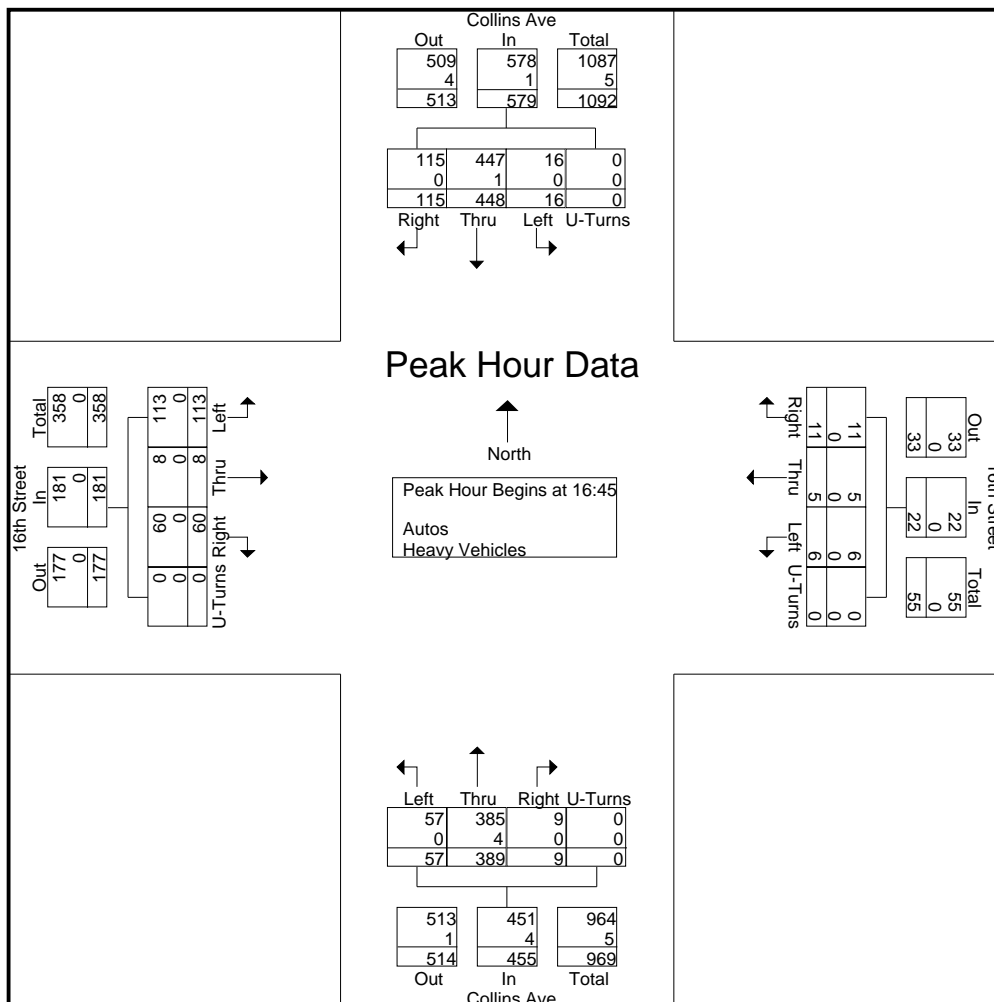

Traff Tech Engineering Inc.

File Name : 4-Collins Ave & 16th St

Site Code : 00000000

Start Date : 6/12/2025

Page No : 4

Start Time	Collins Ave From North					16th Street From East					Collins Ave From South					16th Street From West					Int. Total
	Right	Thru	Left	U-Turns	App. Total	Right	Thru	Left	U-Turns	App. Total	Right	Thru	Left	U-Turns	App. Total	Right	Thru	Left	U-Turns	App. Total	
Peak Hour Analysis From 07:00 to 08:45 - Peak 1 of 1																					
Peak Hour for Entire Intersection Begins at 08:00																					
08:00	26	86	2	0	114	1	1	0	0	2	0	71	8	0	79	9	0	8	0	17	212
08:15	24	99	2	0	125	2	1	0	0	3	3	60	8	0	71	13	0	9	0	22	221
08:30	19	89	3	0	111	1	2	1	0	4	2	63	4	0	69	10	1	11	0	22	206
08:45	27	68	4	0	99	4	1	1	0	6	0	75	3	0	78	13	2	17	0	32	215
Total Volume	96	342	11	0	449	8	5	2	0	15	5	269	23	0	297	45	3	45	0	93	854
% App. Total	21.4	76.2	2.4	0		53.3	33.3	13.3	0		1.7	90.6	7.7	0		48.4	3.2	48.4	0		
PHF	.889	.864	.688	.000	.898	.500	.625	.500	.000	.625	.417	.897	.719	.000	.940	.865	.375	.662	.000	.727	.966
Autos	93	332	11	0	436	8	5	2	0	15	5	256	22	0	283	43	3	43	0	89	823
% Autos	96.9	97.1	100	0	97.1	100	100	100	0	100	100	95.2	95.7	0	95.3	95.6	100	95.6	0	95.7	96.4
Heavy Vehicles	3	10	0	0	13	0	0	0	0	0	0	13	1	0	14	2	0	2	0	4	31
% Heavy Vehicles	3.1	2.9	0	0	2.9	0	0	0	0	0	0	4.8	4.3	0	4.7	4.4	0	4.4	0	4.3	3.6

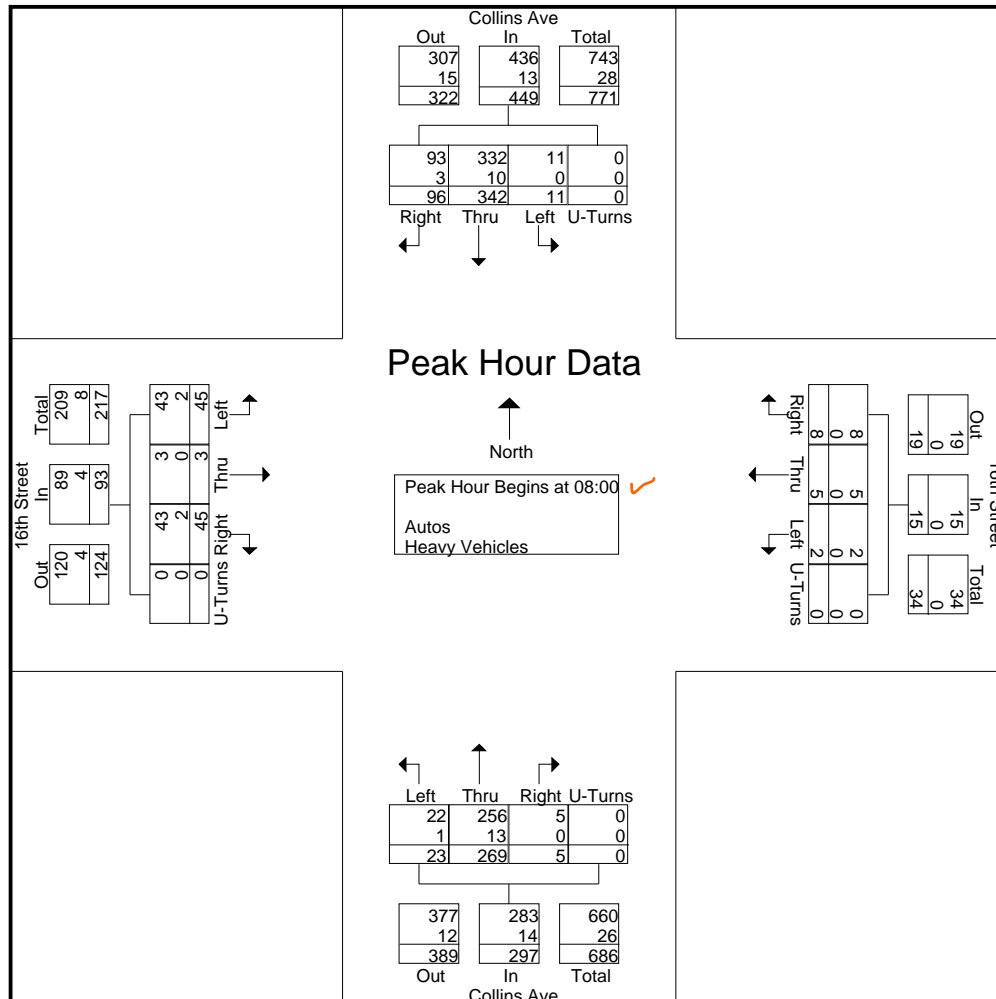

Traff Tech Engineering Inc.

File Name : 4-Collins Ave & 16th St
 Site Code : 00000000
 Start Date : 6/12/2025
 Page No : 5

Start Time	Collins Ave From North					16th Street From East					Collins Ave From South					16th Street From West					Int. Total
	Right	Thru	Left	U-Turns	App. Total	Right	Thru	Left	U-Turns	App. Total	Right	Thru	Left	U-Turns	App. Total	Right	Thru	Left	U-Turns	App. Total	
Peak Hour Analysis From 16:00 to 17:45 - Peak 1 of 1																					
Peak Hour for Entire Intersection Begins at 16:45																					
16:45	25	114	5	0	144	2	3	1	0	6	1	99	10	0	110	18	2	26	0	46	306
17:00	41	92	3	0	136	2	0	2	0	4	2	109	14	0	125	21	1	28	0	50	315
17:15	21	131	2	0	154	2	2	0	0	4	1	94	14	0	109	8	1	26	0	35	302
17:30	28	111	6	0	145	5	0	3	0	8	5	87	19	0	111	13	4	33	0	50	314
Total Volume	115	448	16	0	579	11	5	6	0	22	9	389	57	0	455	60	8	113	0	181	1237
% App. Total	19.9	77.4	2.8	0		50	22.7	27.3	0		2	85.5	12.5	0		33.1	4.4	62.4	0		
PHF	.701	.855	.667	.000	.940	.550	.417	.500	.000	.688	.450	.892	.750	.000	.910	.714	.500	.856	.000	.905	.982
Autos	115	447	16	0	578	11	5	6	0	22	9	385	57	0	451	60	8	113	0	181	1232
% Autos	100	99.8	100	0	99.8	100	100	100	0	100	100	99.0	100	0	99.1	100	100	100	0	100	99.6
Heavy Vehicles	0	1	0	0	1	0	0	0	0	0	0	4	0	0	4	0	0	0	0	0	5
% Heavy Vehicles	0	0.2	0	0	0.2	0	0	0	0	0	0	1.0	0	0	0.9	0	0	0	0	0	0.4

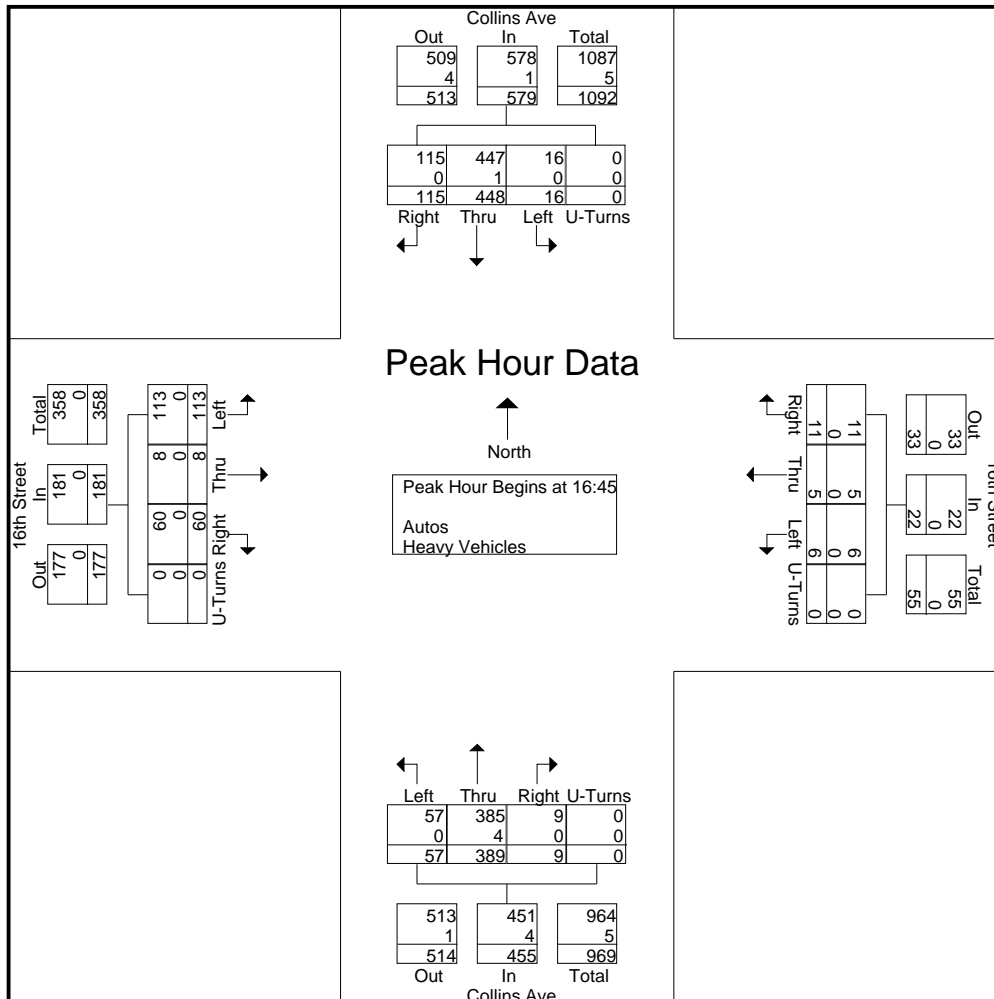

Traff Tech Engineering Inc.

File Name : 4-Collins Ave & 16th St

Site Code : 00000000

Start Date : 6/12/2025

Page No : 1

Groups Printed- Peds & Bikes

Start Time	Collins Ave From North				16th Street From East				Collins Ave From South				16th Street From West				Int. Total
07:00	1	0	0	13	1	0	0	16	0	0	0	29	0	0	0	7	67
07:15	0	0	0	28	2	0	0	28	1	0	0	10	0	0	0	20	89
07:30	0	0	0	27	0	0	0	27	0	0	0	12	0	0	0	13	79
07:45	0	0	0	25	1	0	0	20	1	0	0	18	0	0	0	17	82
Total	1	0	0	93	4	0	0	91	2	0	0	69	0	0	0	57	317
08:00	0	0	0	19	2	0	0	29	1	0	0	11	0	0	0	23	85
08:15	0	0	0	32	0	0	0	27	0	0	0	8	0	0	0	34	101
08:30	0	0	0	22	3	0	0	25	0	0	0	14	0	0	0	44	108
08:45	0	0	0	27	2	0	0	22	0	0	0	7	1	0	0	41	100
Total	0	0	0	100	7	0	0	103	1	0	0	40	1	0	0	142	394
*** BREAK ***																	
16:00	0	0	0	10	3	0	0	23	1	0	0	22	3	0	0	59	121
16:15	1	0	0	14	1	0	0	23	1	0	0	20	4	0	0	65	129
16:30	0	0	0	25	1	0	0	25	0	0	0	30	2	0	0	91	174
16:45	0	0	0	23	3	0	0	18	1	0	0	44	1	0	0	74	164
Total	1	0	0	72	8	0	0	89	3	0	0	116	10	0	0	289	588
17:00	0	0	0	55	3	0	0	36	1	0	0	28	2	0	0	104	229
17:15	0	0	0	35	3	0	0	23	0	0	0	14	2	0	0	121	198
17:30	2	0	0	8	2	0	0	25	2	0	0	18	1	0	0	58	116
17:45	0	0	0	26	0	0	0	33	1	0	0	21	4	0	0	92	177
Total	2	0	0	124	8	0	0	117	4	0	0	81	9	0	0	375	720
Grand Total	4	0	0	389	27	0	0	400	10	0	0	306	20	0	0	863	2019
Apprch %	1	0	0	99	6.3	0	0	93.7	3.2	0	0	96.8	2.3	0	0	97.7	
Total %	0.2	0	0	19.3	1.3	0	0	19.8	0.5	0	0	15.2	1	0	0	42.7	

TOD Schedule Report
for 2707: Drexel Av&16 St ✓

Print Date:
10/4/2021

Print Time:
3:20 PM

<u>Asset</u>	<u>Intersection</u>	<u>TOD Schedule</u>	<u>Op Mode</u>	<u>Plan #</u>	<u>Cycle</u>	<u>Offset</u>	<u>TOD Setting</u>	<u>Active PhaseBank</u>	<u>Active Maximum</u>
2707	Drexel Av&16 St	DOW-2	TOD	N/A	0	0	N/A	0	Max 0

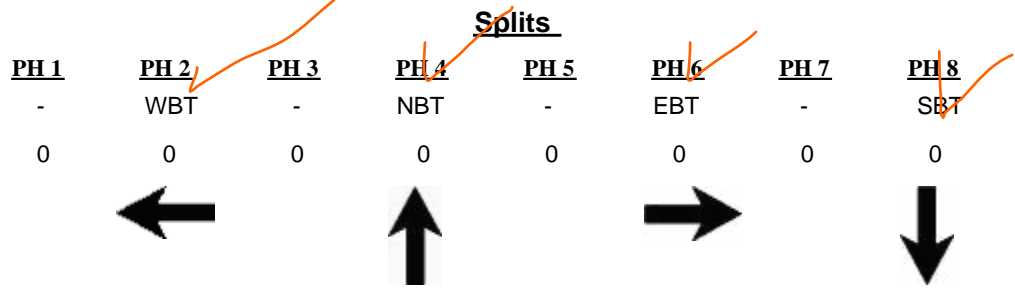

Active Phase Bank: Phase Bank 1

<u>Phase</u>	<u>Walk</u>			<u>Don't Walk</u>			<u>Min Initial</u>			<u>Veh Ext</u>			<u>Max Limit</u>			<u>Max 2</u>			<u>Yellow</u>	<u>Red</u>	
	1	2	3	1	2	3	1	2	3	1	2	3	1	2	3	1	2	3			
1 -	0	-	0	0	-	0	0	-	0	0	-	0	0	-	0	0	-	0	0		0
2 WBT	0	-	5	0	-	21	16	-	5	1	-	1	40	-	30	0	-	40	4		2
3 -	0	-	0	0	-	0	0	-	0	0	-	0	0	-	0	0	-	0	0		0
4 NBT	0	-	5	0	-	21	7	-	7	2.5	-	2.5	22	-	10	16	-	26	4		2
5 -	0	-	0	0	-	0	0	-	0	0	-	0	0	-	0	0	-	0	0		0
6 EBT	0	-	5	0	-	21	16	-	5	1	-	1	40	-	30	0	-	40	4		2
7 -	0	-	0	0	-	0	0	-	0	0	-	0	0	-	0	0	-	0	0		0
8 SBT	0	-	5	0	-	21	7	-	7	2.5	-	2.5	22	-	10	16	-	26	4		2

Last In Service Date: unknown

Permitted Phases	
	12345678
Default	-234-6-8
External Permit 0	-234-6-8
External Permit 1	-234-6-8
External Permit 2	-234-6-8

<u>Current</u>	<u>Plan</u>	<u>Cycle</u>	1	2	3	4	5	6	7	8	<u>Ring Offset</u>	<u>Offset</u>
TOD Schedule			-	WBT	-	NBT	-	EBT	-	SBT		

Local TOD Schedule		
<u>Time</u>	<u>Plan</u>	<u>DOW</u>
0000	Free ✓	Su M T W Th F S

TOD Schedule Report
for 2707: Drexel Av&16 St

Print Date:
10/4/2021

Print Time:
3:20 PM

Current Time of Day Function			
Time	Function	Settings *	Day of Week
0000	TOD OUTPUTS	-7-----1	SuM T W ThF S
0000	TOD LOCAL MULTIFU	----4---	SuM T W ThF S
0130	TOD OUTPUTS	-----	M T W ThF
0330	TOD OUTPUTS	-7-----1	M T ThF
0500	TOD LOCAL MULTIFU	-----	SuM T W ThF S
0500	PED RECALL	8--4---	SuM T W ThF S
0800	<u>TOD OUTPUTS</u>	-----	<u>M T W ThF</u>
0900	TOD OUTPUTS	-7-----1	M T W ThF
2200	PED RECALL	-----	SuM T W ThF S

Local Time of Day Function			
Time	Function	Settings *	Day of Week
0000	TOD OUTPUTS	-7-----1	SuM T W ThF S
0000	TOD LOCAL MULTIFUNCT	----4---	SuM T W ThF S
0130	TOD OUTPUTS	-----	M T W ThF
0230	TOD OUTPUTS	-7-----1	W
0330	TOD OUTPUTS	-7-----1	M T ThF
0500	TOD LOCAL MULTIFUNCT	-----	SuM T W ThF S
0500	PED RECALL	8--4---	SuM T W ThF S
0800	TOD OUTPUTS	-----	M T W ThF
0900	TOD OUTPUTS	-7-----1	M T W ThF
2200	PED RECALL	-----	SuM T W ThF S

* Settings
Blank - FREE - Phase Bank 1, Max 1
Blank - Plan - Phase Bank 1, Max 2
1 - Phase Bank 2, Max 1
2 - Phase Bank 2, Max 2
3 - Phase Bank 3, Max 1
4 - Phase Bank 3, Max 2
5 - EXTERNAL PERMIT 1
6 - EXTERNAL PERMIT 2
7 - X-PED OMIT
8 - TBA

No Calendar Defined/Enabled

TOD Schedule Report
for 2806: Washington Av&16 St ✓

Print Date:
10/4/2021

Print Time:
3:34 PM

<u>Asset</u>	<u>Intersection</u>	<u>TOD Schedule</u>	<u>Op Mode</u>	<u>Plan #</u>	<u>Cycle</u>	<u>Offset</u>	<u>TOD Setting</u>	<u>Active PhaseBank</u>	<u>Active Maximum</u>
2806	Washington Av&16 St	DOW-2	TOD	N/A	0	0	N/A	0	Max 0

Splits

<u>PH 1</u>	<u>PH 2</u>	<u>PH 3</u>	<u>PH 4</u>	<u>PH 5</u>	<u>PH 6</u>	<u>PH 7</u>	<u>PH 8</u>
-	SBT	-	WBT	SBL	NBT	-	EBT
0	0	0	0	0	0	0	0



Active Phase Bank: Phase Bank 1

<u>Phase</u>	<u>Walk</u>			<u>Don't Walk</u>			<u>Min Initial</u>			<u>Veh Ext</u>			<u>Max Limit</u>			<u>Max 2</u>			<u>Yellow</u>	<u>Red</u>
	1	2	3	1	2	3	1	2	3	1	2	3	1	2	3	1	2	3		
1 -	0	0	0	0	0	0	0	0	0	0	0	0	0	0	0	0	0	0	0	0
2 SBT	7	7	7	14	14	14	7	7	7	1	1	1	25	31	25	0	28	28	4	2
3 -	0	0	0	0	0	0	0	0	0	0	0	0	0	0	0	0	0	0	0	0
4 WBT	5	5	5	28	28	28	7	7	7	2.5	2.5	2.5	12	15	12	28	28	28	4	2
5 SBL	0	0	0	0	0	0	5	5	5	2	2	2	5	5	5	7	7	7	4	2
6 NBT	7	7	7	14	14	14	7	7	7	1	1	1	25	31	25	0	28	28	4	2
7 -	0	0	0	0	0	0	0	0	0	0	0	0	0	0	0	0	0	0	0	0
8 EBT	5	5	5	28	28	28	7	7	7	2.5	2.5	2.5	12	15	12	28	28	28	4	2

Last In Service Date: 05/13/2010 12:37

Permitted Phases	
	12345678
Default	-2-456-8
External Permit 0	-2-4-6-8
External Permit 1	-2-4-6-8
External Permit 2	-2-4-6-8

TOD Schedule Report
for 2806: Washington Av&16 St

Print Date:
10/4/2021

Print Time:
3:34 PM

Current TOD Schedule	Plan	Cycle	Green Time								Ring Offset	Offset
			1 -	2 SBT	3 -	4 WBT	5 SBL	6 NBT	7 -	8 EBT		
1		90	0	45	0	33	5	34	0	33	0	60
2		110	0	65	0	33	5	54	0	33	0	20
4		120	0	75	0	33	5	64	0	33	0	12
5		90	0	45	0	33	5	34	0	33	0	45
6 ✓		120 ✓	0	75 ✓	0	33 ✓	5 ✓	64 ✓	0	33 ✓	0	33 ✓
7		90	0	45	0	33	5	34	0	33	0	70
8		110	0	65	0	33	5	54	0	33	0	8
10		110	0	65	0	33	5	54	0	33	0	77
11 ✓		100 ✓	0	55 ✓	0	33 ✓	5 ✓	44 ✓	0	33 ✓	0	1 ✓
12		120	0	75	0	33	5	64	0	33	0	34
14		130	0	85	0	33	5	74	0	33	0	54
15		110	0	65	0	33	5	54	0	33	0	86
16		150	0	105	0	33	5	94	0	33	0	114
18		90	0	45	0	33	5	34	0	33	0	57
19		100	0	55	0	33	5	44	0	33	0	0
20		110	0	65	0	33	5	54	0	33	0	0
21		120	0	75	0	33	5	64	0	33	0	112

Local TOD Schedule		
Time	Plan	DOW
0000	8	Su M T W Th F S
0200	Free	Su M T W Th F S
0530	10	Su S
0545	10	M T W Th F
0715	2	M T W Th F
0800 ✓	11 ✓	<u>M T W Th F</u>
0900	4	M T W Th F
1000	4	Su S
1130	14	M T W Th F
1330	12	M T W Th F
1530 ✓	6 ✓	<u>M T W Th F</u>
1800	8	M T W Th F
2000	8	Su S

Current Time of Day Function			
Time	Function	Settings *	Day of Week
0000	PED RECALL	8--4---	SuM T W ThF S
0000	TOD OUTPUTS	8--5---	SuM T W ThF S
0000	TOD LOCAL MULTIFU	----4---	SuM T W ThF S
0100	TOD OUTPUTS	8--5---1	M T W ThF
0200	TOD OUTPUTS	8--5---	M T W ThF
0500	TOD LOCAL MULTIFU	-----	SuM T W ThF S
0600	TOD OUTPUTS	8--5---	M T W ThF
0715	TOD OUTPUTS	-----	SuM T W ThF S
2300	TOD OUTPUTS	8-----	SuM T W ThF S

Local Time of Day Function			
Time	Function	Settings *	Day of Week
0000	PED RECALL	8--4---	SuM T W ThF S
0000	TOD OUTPUTS	8--5---	SuM T W ThF S
0000	TOD LOCAL MULTIFUNCT	----4---	SuM T W ThF S
0100	TOD OUTPUTS	8--5---1	M T W ThF
0200	TOD OUTPUTS	8--5---	M T W ThF
0500	TOD LOCAL MULTIFUNCT	-----	SuM T W ThF S
0600	TOD OUTPUTS	8--5---	M T W ThF
0715	TOD OUTPUTS	-----	SuM T W ThF S
2300	TOD OUTPUTS	8-----	SuM T W ThF S

* Settings
Blank - FREE - Phase Bank 1, Max 1
Blank - Plan - Phase Bank 1, Max 2
1 - Phase Bank 2, Max 1
2 - Phase Bank 2, Max 2
3 - Phase Bank 3, Max 1
4 - Phase Bank 3, Max 2
5 - EXTERNAL PERMIT 1
6 - EXTERNAL PERMIT 2
7 - X-PED OMIT
8 - TBA

No Calendar Defined/Enabled

TOD Schedule Report
for 5769: Collins Av&16 St

Print Date:
10/4/2021

Print Time:
8:44 PM

<u>Asset</u>	<u>Intersection</u>	<u>TOD Schedule</u>	<u>Op Mode</u>	<u>Plan #</u>	<u>Cycle</u>	<u>Offset</u>	<u>TOD Setting</u>	<u>Active PhaseBank</u>	<u>Active Maximum</u>
5769	Collins Av&16 St	DOW-2	TOD	N/A	0	0	N/A	0	Max 0

Splits

<u>PH 1</u>	<u>PH 2</u>	<u>PH 3</u>	<u>PH 4</u>	<u>PH 5</u>	<u>PH 6</u>	<u>PH 7</u>	<u>PH 8</u>
-	SBT	-	WBT	-	NBT	-	EBT
0	0	0	0	0	0	0	0

Active Phase Bank: Phase Bank 1

Phase	<u>Walk</u>			<u>Don't Walk</u>			<u>Min Initial</u>			<u>Veh Ext</u>			<u>Max Limit</u>			<u>Max 2</u>			<u>Yellow</u>	<u>Red</u>
	1	2	3	1	2	3	1	2	3	1	2	3	1	2	3	1	2	3		
1 -	0	0	0	0	0	0	0	0	0	0	0	0	0	0	0	0	0	0	0	0
2 SBT	7	7	7	21	21	21	5	5	5	1	1	1	55	55	55	0	55	55	4	2.2
3 -	0	0	0	0	0	0	0	0	0	0	0	0	0	0	0	0	0	0	0	0
4 WBT	7	7	7	13	13	13	7	7	7	2.5	2.5	2.5	12	12	12	25	25	25	4	2
5 -	0	0	0	0	0	0	0	0	0	0	0	0	0	0	0	0	0	0	0	0
6 NBT	7	7	7	21	21	21	5	5	5	1	1	1	55	55	55	0	55	55	4	2.2
7 -	0	0	0	0	0	0	0	0	0	0	0	0	0	0	0	0	0	0	0	0
8 EBT	7	7	7	13	13	13	7	7	7	2.5	2.5	2.5	12	12	12	25	25	25	4	2

Last In Service Date: unknown

Permitted Phases	
	12345678
Default	-2-4-6-8
External Permit 0	-2-4-6-8
External Permit 1	-2-4-6-8
External Permit 2	-2-4-6-8

TOD Schedule Report
for 5769: Collins Av&16 St

Print Date:
10/4/2021

Print Time:
8:44 PM

Current TOD Schedule	Plan	Cycle	Green Time								Ring Offset	Offset
			1 -	2 SBT	3 -	4 WBT	5 -	6 NBT	7 -	8 EBT		
1		100	0	64	0	24	0	64	0	24	0	74
2		100	0	64	0	24	0	64	0	24	0	54
3		100	0	64	0	24	0	64	0	24	0	65
4		100	0	64	0	24	0	64	0	24	0	68
5		110	0	74	0	24	0	74	0	24	0	101
6		130	0	94	0	24	0	94	0	24	0	10
7		120	0	84	0	24	0	84	0	24	0	102
8		110	0	74	0	24	0	74	0	24	0	8
9		120	0	84	0	24	0	84	0	24	0	90
11		120	0	84	0	24	0	84	0	24	0	90
12		90	0	54	0	24	0	54	0	24	0	13
13		90	0	54	0	24	0	54	0	24	0	57
14		120	0	84	0	24	0	84	0	24	0	89
15		120	0	84	0	24	0	84	0	24	0	91
16		90	0	54	0	24	0	54	0	24	0	61
17		90	0	54	0	24	0	54	0	24	0	72
21		90	0	54	0	24	0	54	0	24	0	17
22		100	0	64	0	24	0	64	0	24	0	21
23		100	0	64	0	24	0	64	0	24	0	17
25		140	0	103	0	25	0	103	0	25	0	80

Local TOD Schedule		
Time	Plan	DOW
0000	1	Su M T W Th
0300	22	M T W Th
0300	4	Su
0700	5	Su
0700	1	M T W Th F S
0930	2	M T W Th
1000	8	Su F S
1500	11	Su F S
1500	3	M T W Th
1800	12	M T W Th F
1800	6	Su S
2200	1	M T W Th
2200	6	F

Current Time of Day Function			
Time	Function	Settings *	Day of Week
0000	TOD OUTPUTS	-----	SuM T W ThF S
0000	PED RECALL	-----	SuM T W

Local Time of Day Function			
Time	Function	Settings *	Day of Week
0000	TOD OUTPUTS	-----	SuM T W ThF S
0000	PED RECALL	8---4---	ThF S
0000	PED RECALL	-----	SuM T W
0200	PED RECALL	-----	ThF S
0500	PED RECALL	8---4---	Su S

* Settings
Blank - FREE - Phase Bank 1, Max 1
Blank - Plan - Phase Bank 1, Max 2
1 - Phase Bank 2, Max 1
2 - Phase Bank 2, Max 2
3 - Phase Bank 3, Max 1
4 - Phase Bank 3, Max 2
5 - EXTERNAL PERMIT 1
6 - EXTERNAL PERMIT 2
7 - X-PED OMIT
8 - TBA

TOD Schedule Report
for 5769: Collins Av&16 St

Print Date:
10/4/2021

Print Time:
8:44 PM

No Calendar Defined/Enabled

TRAFFIC SIGNAL INTERVAL DIAGRAMS

PHASE	INT	SIGNAL HEAD NUMBER												PEDESTRIAN HEAD NUMBER								
		1	2	3	4	5	6	7	8	9	10	11	12	P2	P4	P6	P8					
02 (2 + 6) 16 ST (RECALL)	R/W	○	G	○	R	○	G	○	R	○	○	○	○	○	DW	DW	DW	DW	○	○		
	EXCL. PED.	○	Y	○	R	○	Y	○	R	○	○	○	○	○	DW	DW	DW	DW	○	○		
	TO 04	○	Y	○	R	○	Y	○	R	○	○	○	○	○	DW	DW	DW	DW	○	○		
	CLEAR	○	○	○	○	○	○	○	○	○	○	○	○	○	○	○	○	○	○	○		○
	CLEAR	○	○	○	○	○	○	○	○	○	○	○	○	○	○	○	○	○	○	○		○
EXCL. PED. (P2 + P4 + P6 + P8) (ACTUATED)	R/W	○	R	○	R	○	R	○	R	○	○	○	○	○	W	W	W	W	○	○		
	TO 04	○	R	○	R	○	R	○	R	○	○	○	○	○	FDW	FDW	FDW	FDW	○	○		
	TO 02	○	R	○	R	○	R	○	R	○	○	○	○	○	FDW	FDW	FDW	FDW	○	○		
	CLEAR	○	○	○	○	○	○	○	○	○	○	○	○	○	○	○	○	○	○	○		○
	CLEAR	○	○	○	○	○	○	○	○	○	○	○	○	○	○	○	○	○	○	○		○
04 (4 + 6) DREXEL AVE (ACTUATED)	R/W	○	R	○	G	○	R	○	G	○	○	○	○	○	DW	DW	DW	DW	○	○		
	TO 02	○	R	○	Y	○	R	○	Y	○	○	○	○	○	DW	DW	DW	DW	○	○		
	CLEAR	○	○	○	○	○	○	○	○	○	○	○	○	○	○	○	○	○	○	○		○
	CLEAR	○	○	○	○	○	○	○	○	○	○	○	○	○	○	○	○	○	○	○		○
	CLEAR	○	○	○	○	○	○	○	○	○	○	○	○	○	○	○	○	○	○	○		○



Drawn C.L. ROQUE	Date 12/10/86	METROPOLITAN DADE COUNTY DEPARTMENT OF TRAFFIC AND TRANSPORTATION	
Check E. Lee	Date 12/10/86	ASSET NO: 32707 DREXEL AVE. & 16 STREET	
Division Engineer	Date	Placed In Service Date: 7/23/86 By: CONTRACTOR	
			Phasing Number 2

SIGNAL OPERATING PLAN

		SIGNAL HEAD NUMBER													
PHASE	INT	2	6	4	4R	5	8	P2	P6	P4	P8				
Φ2+6 (2+6+P2+P6) NBND & SBND WASHINGTON AV RECALL ✓	R/W	G	G	R	R	G	R	W	W	DW	DW				
	PED. CL	G	G	R	R	G	R	FW	FW	DW	DW				
	TO	Φ4+8	Y	Y	R	R	Y	R	DW	DW	DW			DW	
	CLEAR														
Φ4+8 (4+8+P4+P8) EBND & WBND 16 ST ACTUATED BY: L4, L8 P4, P8	R/W	R	R	G	F	R	G	DW	DW	W	W				
	PED. CL	R	R	G	F	R	G	DW	DW	FW	FW				
	TO	Φ2+5	R	R	Y	Y	R	Y	DW	DW	DW			DW	
	CLEAR	Φ2+6	R	R	Y	Y	R	Y	DW	DW	DW			DW	
Φ2+5 (2+5+4R+P2) SBND & SBLT & WBRT WASHINGTON AV. ACTUATED BY L5	R/W	G	R	R	R	R	R	W	DW	DW	DW	DW			
	PED. CL	G	R	R	R	R	R	FW	DW	DW	DW	DW			
	TO	Φ2+6	G	R	R	R	R	R	FW	DW	DW	DW			DW
	CLEAR														
FLASH OPERATION	R/W														
	PED. CL														
	TO														
	CLEAR														

Drawn	Date	MIAMI-DADE COUNTY DEPARTMENT OF PUBLIC WORKS	
H. FRANCIILLON	10/14/98	ASSET NO. 2806	
Check	Date	WASHINGTON AV & 16 ST	
H. HEINWUDEL	10/19/98		
Division Engineer	Date		
		Placed in Service	Phasing Number
		Date: 10/15/98	By: DTI
			4

SIGNAL OPERATING PLAN



Timing Phases	Direction	NB	SB	EB	WB	Ped Heads				Movements/Display/Actuation	
	Head No.	6	2	8	4	P6	P2	P8	P4		
	Dwell										
	C l e a r t o										
	Dwell										
	C l e a r t o										
(2+6) N/SB Collins Av (RECALL)	Dwell	G	G	R	R	W/F	W/F	DW	DW		
	C l e a r t o	4+8	Y	Y	R	R	DW	DW	DW		DW
	Dwell										
	C l e a r t o										
(4+8) E/WB 16 Street (ACTUATED)	Dwell	R	R	G	G	DW	DW	W/F	W/F		
	C l e a r t o	2+6	R	R	Y	Y	DW	DW	DW		DW
	Dwell										
	C l e a r t o										

Flashing Operation

FY

FY

FR

FR

Page 1 of 1

Miami-Dade County Public Works Department

Drawn WILLIAM RIVERA PAZ	Date 1/7/2014	COLLINS AV & 16 STREET ✓			
Checked <i>U. Hernandez</i>	Date 1/9/14	Placed in Service		Phasing No.	Asset Number
		Date 12/01/2014	By UND	4	5769

Historical Intersection Timing Report Int: Drexel Av&16 St (2707)

Start Time: 7/11/25 08:20 End Time: 7/11/25 09:19

Print Date 07/11/2025

Print Time 11:53 AM

<u>Time</u>	<u>Plan</u>	<u>Ring 1 Phase</u>	<u>Interval</u>	<u>Grn Dur</u>	<u>Ring 2 Phase</u>	<u>Interval</u>	<u>Grn Dur</u>	<u>Status</u>	<u>Poll Freq</u>
7/11 08:20:59	Fr	4-NBT	Clear		8-SBT	Clear		Free	
7/11 08:21:05		2-WBT	Green	40	6-EBT	Green	40		
7/11 08:21:45		2-WBT	Clear		6-EBT	Clear			
7/11 08:21:51		4-NBT	Green	22	8-SBT	Green	22		
7/11 08:22:13	Fr	4-NBT	Clear		8-SBT	Clear		Free	
7/11 08:22:19		2-WBT	Green	39	6-EBT	Green	39		
7/11 08:22:58		2-WBT	Clear		6-EBT	Clear			
7/11 08:23:05		4-NBT	Green	22	8-SBT	Green	22		
7/11 08:23:27	Fr	4-NBT	Clear		8-SBT	Clear		Free	
7/11 08:23:33		2-WBT	Green	40	6-EBT	Green	40		
7/11 08:24:13		2-WBT	Clear		6-EBT	Clear			
7/11 08:24:19		4-NBT	Green	22	8-SBT	Green	22		
7/11 08:24:41	Fr	4-NBT	Clear		8-SBT	Clear		Free	
7/11 08:24:47		2-WBT	Green	40	6-EBT	Green	40		
7/11 08:25:27		2-WBT	Clear		6-EBT	Clear			
7/11 08:25:33		4-NBT	Green	21	8-SBT	Green	21		
7/11 08:25:54	Fr	4-NBT	Clear		8-SBT	Clear		Free	
7/11 08:26:01		2-WBT	Green	39	6-EBT	Green	39		
7/11 08:26:40		2-WBT	Clear		6-EBT	Clear			
7/11 08:26:47		4-NBT	Green	22	8-SBT	Green	22		
7/11 08:27:09	Fr	4-NBT	Clear		8-SBT	Clear		Free	
7/11 08:27:15		2-WBT	Green	39	6-EBT	Green	39		
7/11 08:27:54		2-WBT	Clear		6-EBT	Clear			
7/11 08:28:01		4-NBT	Green	22	8-SBT	Green	22		
7/11 08:28:23	Fr	4-NBT	Clear		8-SBT	Clear		Free	
7/11 08:28:29		2-WBT	Green	39	6-EBT	Green	39		
7/11 08:29:08		2-WBT	Clear		6-EBT	Clear			
7/11 08:29:15		4-NBT	Green	22	8-SBT	Green	22		
7/11 08:29:37	Fr	4-NBT	Clear		8-SBT	Clear		Free	
7/11 08:29:43		2-WBT	Green	40	6-EBT	Green	40		
7/11 08:30:23		2-WBT	Clear		6-EBT	Clear			
7/11 08:30:29		4-NBT	Green	21	8-SBT	Green	21		
7/11 08:30:50	Fr	4-NBT	Clear		8-SBT	Clear		Free	
7/11 08:30:57		2-WBT	Green	40	6-EBT	Green	40		
7/11 08:31:37		2-WBT	Clear		6-EBT	Clear			
7/11 08:31:43		4-NBT	Green	21	8-SBT	Green	21		
7/11 08:32:04	Fr	4-NBT	Clear		8-SBT	Clear		Free	
7/11 08:32:11		2-WBT	Green	39	6-EBT	Green	39		
7/11 08:32:50		2-WBT	Clear		6-EBT	Clear			
7/11 08:32:57		4-NBT	Green	22	8-SBT	Green	22		
7/11 08:33:19	Fr	4-NBT	Clear		8-SBT	Clear		Free	
7/11 08:33:25		2-WBT	Green	40	6-EBT	Green	40		
7/11 08:34:05		2-WBT	Clear		6-EBT	Clear			
7/11 08:34:11			XPED			XPED			
7/11 08:34:39		4-NBT	Green	21	8-SBT	Green	21		
7/11 08:35:00	Fr	4-NBT	Clear		8-SBT	Clear		Free	
7/11 08:35:06		2-WBT	Green	40	6-EBT	Green	40		
7/11 08:35:46		2-WBT	Clear		6-EBT	Clear			
7/11 08:35:53		4-NBT	Green	21	8-SBT	Green	21		
7/11 08:36:14	Fr	4-NBT	Clear		8-SBT	Clear		Free	
7/11 08:36:21		2-WBT	Green	39	6-EBT	Green	39		
7/11 08:37:00		2-WBT	Clear		6-EBT	Clear			
7/11 08:37:06		4-NBT	Green	23	8-SBT	Green	23		
7/11 08:37:29	Fr	4-NBT	Clear		8-SBT	Clear		Free	
7/11 08:37:35		2-WBT	Green	40	6-EBT	Green	40		
7/11 08:38:15		2-WBT	Clear		6-EBT	Clear			
7/11 08:38:21		4-NBT	Green	21	8-SBT	Green	21		
7/11 08:38:42	Fr	4-NBT	Clear		8-SBT	Clear		Free	
7/11 08:38:49		2-WBT	Green	40	6-EBT	Green	40		
7/11 08:39:29		2-WBT	Clear		6-EBT	Clear			
7/11 08:39:35		4-NBT	Green	21	8-SBT	Green	21		
7/11 08:39:56	Fr	4-NBT	Clear		8-SBT	Clear		Free	
7/11 08:40:02		2-WBT	Green	40	6-EBT	Green	40		
7/11 08:40:42		2-WBT	Clear		6-EBT	Clear			
7/11 08:40:49		4-NBT	Green	21	8-SBT	Green	21		
7/11 08:41:10	Fr	4-NBT	Clear		8-SBT	Clear		Free	

Historical Intersection Timing Report Int: Drexel Av&16 St (2707)

Start Time: 7/11/25 08:20 End Time: 7/11/25 09:19

Print Date 07/11/2025

Print Time 11:53 AM

Time	Plan	Ring 1 Phase	Interval	Grn Dur	Ring 2 Phase	Interval	Grn Dur	Status	Poll Freq
7/11 08:41:17		2-WBT	Green	39	6-EBT	Green	39		
7/11 08:41:56		2-WBT	Clear		6-EBT	Clear			
7/11 08:42:02		4-NBT	Green	22	8-SBT	Green	22		
7/11 08:42:24	Fr	4-NBT	Clear		8-SBT	Clear		Free	
7/11 08:42:31		2-WBT	Green	39	6-EBT	Green	39		
7/11 08:43:10		2-WBT	Clear		6-EBT	Clear			
7/11 08:43:17		4-NBT	Green	21	8-SBT	Green	21		
7/11 08:43:38	Fr	4-NBT	Clear		8-SBT	Clear		Free	
7/11 08:43:45		2-WBT	Green	40	6-EBT	Green	40		
7/11 08:44:25		2-WBT	Clear		6-EBT	Clear			
7/11 08:44:31		4-NBT	Green	21	8-SBT	Green	21		
7/11 08:44:52	Fr	4-NBT	Clear		8-SBT	Clear		Free	
7/11 08:44:58		2-WBT	Green	40 ✓	6-EBT	Green	40		
7/11 08:45:38		2-WBT	Clear		6-EBT	Clear			
7/11 08:45:45			XPED ✓ ?			XPED ✓ ○			
7/11 08:46:12		4-NBT	Green	22 ✓	8-SBT	Green	22		
7/11 08:46:34	Fr	4-NBT	Clear		8-SBT	Clear		Free	
7/11 08:46:41		2-WBT	Green	39	6-EBT	Green	39		
7/11 08:47:20		2-WBT	Clear		6-EBT	Clear			
7/11 08:47:26		4-NBT	Green	22	8-SBT	Green	22		
7/11 08:47:48	Fr	4-NBT	Clear		8-SBT	Clear		Free	
7/11 08:47:54		2-WBT	Green	40	6-EBT	Green	40		
7/11 08:48:34		2-WBT	Clear		6-EBT	Clear			
7/11 08:48:41		4-NBT	Green	21	8-SBT	Green	21		
7/11 08:49:02	Fr	4-NBT	Clear		8-SBT	Clear		Free	
7/11 08:49:09		2-WBT	Green	39	6-EBT	Green	39		
7/11 08:49:48		2-WBT	Clear		6-EBT	Clear			
7/11 08:49:55		4-NBT	Green	21	8-SBT	Green	21		
7/11 08:50:16	Fr	4-NBT	Clear		8-SBT	Clear		Free	
7/11 08:50:22		2-WBT	Green	40	6-EBT	Green	40		
7/11 08:51:02		2-WBT	Clear		6-EBT	Clear			
7/11 08:51:08		4-NBT	Green	22	8-SBT	Green	22		
7/11 08:51:30	Fr	4-NBT	Clear		8-SBT	Clear		Free	
7/11 08:51:37		2-WBT	Green	39	6-EBT	Green	39		
7/11 08:52:16		2-WBT	Clear		6-EBT	Clear			
7/11 08:52:22		4-NBT	Green	22	8-SBT	Green	22		
7/11 08:52:44	Fr	4-NBT	Clear		8-SBT	Clear		Free	
7/11 08:52:50		2-WBT	Green	40	6-EBT	Green	40		
7/11 08:53:30		2-WBT	Clear		6-EBT	Clear			
7/11 08:53:37		4-NBT	Green	21	8-SBT	Green	21		
7/11 08:53:58	Fr	4-NBT	Clear		8-SBT	Clear		Free	
7/11 08:54:04		2-WBT	Green	40	6-EBT	Green	40		
7/11 08:54:44		2-WBT	Clear		6-EBT	Clear			
7/11 08:54:50		4-NBT	Green	22	8-SBT	Green	22		
7/11 08:55:12	Fr	4-NBT	Clear		8-SBT	Clear		Free	
7/11 08:55:19		2-WBT	Green	39	6-EBT	Green	39		
7/11 08:55:58		2-WBT	Clear		6-EBT	Clear			
7/11 08:56:04		4-NBT	Green	22	8-SBT	Green	22		
7/11 08:56:26	Fr	4-NBT	Clear		8-SBT	Clear		Free	
7/11 08:56:33		2-WBT	Green	39	6-EBT	Green	39		
7/11 08:57:12		2-WBT	Clear		6-EBT	Clear			
7/11 08:57:19		4-NBT	Green	21	8-SBT	Green	21		
7/11 08:57:40	Fr	4-NBT	Clear		8-SBT	Clear		Free	
7/11 08:57:46		2-WBT	Green	40	6-EBT	Green	40		
7/11 08:58:26		2-WBT	Clear		6-EBT	Clear			
7/11 08:58:33		4-NBT	Green	21	8-SBT	Green	21		
7/11 08:58:54	Fr	4-NBT	Clear		8-SBT	Clear		Free	
7/11 08:59:00		2-WBT	Green	40	6-EBT	Green	40		
7/11 08:59:40		2-WBT	Clear		6-EBT	Clear			
7/11 08:59:47			XPED			XPED			
7/11 09:00:14		4-NBT	Green	10	8-SBT	Green	10		
7/11 09:00:24	Fr	4-NBT	Clear		8-SBT	Clear		Free	
7/11 09:00:30		2-WBT	Green	40	6-EBT	Green	40		
7/11 09:01:10		2-WBT	Clear		6-EBT	Clear			
7/11 09:01:16		4-NBT	Green	10	8-SBT	Green	10		
7/11 09:01:26	Fr	4-NBT	Clear		8-SBT	Clear		Free	

Historical Intersection Timing Report Int: Drexel Av&16 St (2707)

Start Time: 7/11/25 08:20 End Time: 7/11/25 09:19

Print Date 07/11/2025

Print Time 11:53 AM

Time	Plan	Ring 1 Phase	Interval	Grn Dur	Ring 2 Phase	Interval	Grn Dur	Status	Poll Freq
7/11 09:01:32		2-WBT	Green	40	6-EBT	Green	40		
7/11 09:02:12		2-WBT	Clear		6-EBT	Clear			
7/11 09:02:18		4-NBT	Green	10	8-SBT	Green	10		
7/11 09:02:28	Fr	4-NBT	Clear		8-SBT	Clear		Free	
7/11 09:02:34		2-WBT	Green	40	6-EBT	Green	40		
7/11 09:03:14		2-WBT	Clear		6-EBT	Clear			
7/11 09:03:20		4-NBT	Green	10	8-SBT	Green	10		
7/11 09:03:30	Fr	4-NBT	Clear		8-SBT	Clear		Free	
7/11 09:03:36		2-WBT	Green	40	6-EBT	Green	40		
7/11 09:04:16		2-WBT	Clear		6-EBT	Clear			
7/11 09:04:22		4-NBT	Green	10	8-SBT	Green	10		
7/11 09:04:32	Fr	4-NBT	Clear		8-SBT	Clear		Free	
7/11 09:04:38		2-WBT	Green	40	6-EBT	Green	40		
7/11 09:05:18		2-WBT	Clear		6-EBT	Clear			
7/11 09:05:24		4-NBT	Green	10	8-SBT	Green	10		
7/11 09:05:34	Fr	4-NBT	Clear		8-SBT	Clear		Free	
7/11 09:05:40		2-WBT	Green	40	6-EBT	Green	40		
7/11 09:06:20		2-WBT	Clear		6-EBT	Clear			
7/11 09:06:26		4-NBT	Green	10	8-SBT	Green	10		
7/11 09:06:36	Fr	4-NBT	Clear		8-SBT	Clear		Free	
7/11 09:06:42		2-WBT	Green	39	6-EBT	Green	39		
7/11 09:07:21		2-WBT	Clear		6-EBT	Clear			
7/11 09:07:28		4-NBT	Green	9	8-SBT	Green	9		
7/11 09:07:37	Fr	4-NBT	Clear		8-SBT	Clear		Free	
7/11 09:07:44		2-WBT	Green	40	6-EBT	Green	40		
7/11 09:08:24		2-WBT	Clear		6-EBT	Clear			
7/11 09:08:30		4-NBT	Green	10	8-SBT	Green	10		
7/11 09:08:40	Fr	4-NBT	Clear		8-SBT	Clear		Free	
7/11 09:08:46		2-WBT	Green	39	6-EBT	Green	39		
7/11 09:09:25		2-WBT	Clear		6-EBT	Clear			
7/11 09:09:31		4-NBT	Green	10	8-SBT	Green	10		
7/11 09:09:41	Fr	4-NBT	Clear		8-SBT	Clear		Free	
7/11 09:09:47		2-WBT	Green	40	6-EBT	Green	40		
7/11 09:10:27		2-WBT	Clear		6-EBT	Clear			
7/11 09:10:33		4-NBT	Green	10	8-SBT	Green	10		
7/11 09:10:43	Fr	4-NBT	Clear		8-SBT	Clear		Free	
7/11 09:10:49		2-WBT	Green	40	6-EBT	Green	40		
7/11 09:11:29		2-WBT	Clear		6-EBT	Clear			
7/11 09:11:35		4-NBT	Green	10	8-SBT	Green	10		
7/11 09:11:45	Fr	4-NBT	Clear		8-SBT	Clear		Free	
7/11 09:11:51		2-WBT	Green	40	6-EBT	Green	40		
7/11 09:12:31		2-WBT	Clear		6-EBT	Clear			
7/11 09:12:37		4-NBT	Green	10	8-SBT	Green	10		
7/11 09:12:47	Fr	4-NBT	Clear		8-SBT	Clear		Free	
7/11 09:12:53		2-WBT	Green	40	6-EBT	Green	40		
7/11 09:13:33		2-WBT	Clear		6-EBT	Clear			
7/11 09:13:39		4-NBT	Green	10	8-SBT	Green	10		
7/11 09:13:49	Fr	4-NBT	Clear		8-SBT	Clear		Free	
7/11 09:13:55		2-WBT	Green	40	6-EBT	Green	40		
7/11 09:14:35		2-WBT	Clear		6-EBT	Clear			
7/11 09:14:41		4-NBT	Green	10	8-SBT	Green	10		
7/11 09:14:51	Fr	4-NBT	Clear		8-SBT	Clear		Free	
7/11 09:14:57		2-WBT	Green	40	6-EBT	Green	40		
7/11 09:15:37		2-WBT	Clear		6-EBT	Clear			
7/11 09:15:43		4-NBT	Green	10	8-SBT	Green	10		
7/11 09:15:53	Fr	4-NBT	Clear		8-SBT	Clear		Free	
7/11 09:15:59		2-WBT	Green	40	6-EBT	Green	40		
7/11 09:16:39		2-WBT	Clear		6-EBT	Clear			
7/11 09:16:45		4-NBT	Green	10	8-SBT	Green	10		
7/11 09:16:55	Fr	4-NBT	Clear		8-SBT	Clear		Free	
7/11 09:17:01		2-WBT	Green	40	6-EBT	Green	40		
7/11 09:17:41		2-WBT	Clear		6-EBT	Clear			
7/11 09:17:47		4-NBT	Green	10	8-SBT	Green	10		
7/11 09:17:57	Fr	4-NBT	Clear		8-SBT	Clear		Free	
7/11 09:18:03		2-WBT	Green	39	6-EBT	Green	39		
7/11 09:18:42		2-WBT	Clear		6-EBT	Clear			

Historical Intersection Timing Report Int: Drexel Av&16 St (2707)

Start Time: 7/11/25 08:20 End Time: 7/11/25 09:19

Print Date 07/11/2025

Print Time 11:53 AM

<u>Time</u>	<u>Plan</u>	<u>Ring 1 Phase</u>	<u>Interval</u>	<u>Grn Dur</u>	<u>Ring 2 Phase</u>	<u>Interval</u>	<u>Grn Dur</u>	<u>Status</u>	<u>Poll Freq</u>
7/11 09:18:49		4-NBT	Green	10	8-SBT	Green	10		
7/11 09:18:59	Fr	4-NBT	Clear		8-SBT	Clear		Free	
7/11 09:19:05		2-WBT	Green	40	6-EBT	Green	40		

Summary

Plan: Free Start Time: 7/11 08:20:37 End Time: 7/11 09:19:45

Cycle:0 Offset:0

Phases in use: 1 2-WBT 3-XPD 4-NBT 5 6-EBT 7 8-SBT
 Splits 0 0 0 0 0 0 16 16

Overlaps in use: A:A LOADSW 0 B:B LOADSW 0 C:C LOADSW 0 D:D LOADSW 0 E:E
 LOADSW 0 F:F LOADSW 0 G:G LOADSW 0 H:H LOADSW 0

Number of full cycles in period: 50
 Number of preempts: EV: 0 RR: 0 Spec Events: 0
 Number of comm. failures: 0
 Number of gaps in poll messages: 0
 Number of Busway services: 0
 Number of Low Priority services: 0

Phase	1	2	3	4	5	6	7	8	XPED
Actuation	0	50 ✓	0	50	0	50	0	50	3 ✓
Omits	50	0	50	0	50	0	50	0	47
Max Out	0	0	0	0	0	0	0	30	
Min Svc	0	0	0	0	0	0	0	0	
Avg Grn	0.0	39.7	0.0	16.9	0.0	39.7	0.0	16.9	54.7
Min Grn	0	39	0	9	0	39	0	9	54
Max Grn	0	40	0	23	0	40	0	23	56 ✓
Std. Dev	0.0	0.5	0.0	5.8	0.0	0.5	0.0	5.8	1.2
Avg G/C(%)	0	56.0	0	23.9	0	56.0	0	23.9	4.6

Historical Intersection Timing Report Int: Collins Av&16 St (5769)

Start Time: 7/11/25 08:20 End Time: 7/11/25 09:19

Print Date 07/11/2025

Print Time 11:55 AM

Time	Plan	Ring 1 Phase	Interval	Grn Dur	Ring 2 Phase	Interval	Grn Dur	Status	Poll Freq
7/11 08:21:28	1	2-SBT			6-NBT			Coord	
7/11 08:21:29		2-SBT	Clear		6-NBT	Clear			
7/11 08:21:35		4-WBT	Green	12	8-EBT	Green	12		
7/11 08:21:47	1	4-WBT	Clear		8-EBT	Clear		Coord	
7/11 08:21:54		2-SBT	Green	74	6-NBT	Green	74		
7/11 08:23:08		2-SBT	Clear		6-NBT	Clear			
7/11 08:23:15		4-WBT	Green	19	8-EBT	Green	19		
7/11 08:23:34	1	4-WBT	Clear		8-EBT	Clear		Coord	
7/11 08:23:41		2-SBT	Green	68	6-NBT	Green	68		
7/11 08:24:48		2-SBT			6-NBT				
7/11 08:24:49		2-SBT	Clear		6-NBT	Clear			
7/11 08:24:55		4-WBT	Green	20	8-EBT	Green	20		
7/11 08:25:15	1	4-WBT	Clear		8-EBT	Clear		Coord	
7/11 08:25:21		2-SBT	Green	68	6-NBT	Green	68		
7/11 08:26:28		2-SBT			6-NBT				
7/11 08:26:29		2-SBT	Clear		6-NBT	Clear			
7/11 08:26:35		4-WBT	Green	7	8-EBT	Green	7		
7/11 08:26:42	1	4-WBT	Clear		8-EBT	Clear		Coord	
7/11 08:26:48		2-SBT	Green	81	6-NBT	Green	81		
7/11 08:28:08		2-SBT			6-NBT				
7/11 08:28:09		2-SBT	Clear		6-NBT	Clear			
7/11 08:28:15		4-WBT	Green	20	8-EBT	Green	20		
7/11 08:28:35	1	4-WBT	Clear		8-EBT	Clear		Coord	
7/11 08:28:41		2-SBT	Green	67	6-NBT	Green	67		
7/11 08:29:48		2-SBT	Clear		6-NBT	Clear			
7/11 08:29:54		4-WBT	Green	20	8-EBT	Green	20		
7/11 08:30:14	1	4-WBT	Clear		8-EBT	Clear		Coord	
7/11 08:30:20		2-SBT	Green	69	6-NBT	Green	69		
7/11 08:31:28		2-SBT			6-NBT				
7/11 08:31:29		2-SBT	Clear		6-NBT	Clear			
7/11 08:31:35		4-WBT	Green	7	8-EBT	Green	7		
7/11 08:31:42	1	4-WBT	Clear		8-EBT	Clear		Coord	
7/11 08:31:48		2-SBT	Green	80	6-NBT	Green	80		
7/11 08:33:08		2-SBT	Clear		6-NBT	Clear			
7/11 08:33:15		4-WBT	Green	8	8-EBT	Green	8		
7/11 08:33:23	1	4-WBT	Clear		8-EBT	Clear		Coord	
7/11 08:33:29		2-SBT	Green	79	6-NBT	Green	79		
7/11 08:34:48		2-SBT	Clear		6-NBT	Clear			
7/11 08:34:55		4-WBT	Green	16	8-EBT	Green	16		
7/11 08:35:11	1	4-WBT	Clear		8-EBT	Clear		Coord	
7/11 08:35:17		2-SBT	Green	72	6-NBT	Green	72		
7/11 08:36:28		2-SBT			6-NBT				
7/11 08:36:29		2-SBT	Clear		6-NBT	Clear			
7/11 08:36:35		4-WBT	Green	20	8-EBT	Green	20		
7/11 08:36:55	1	4-WBT	Clear		8-EBT	Clear		Coord	
7/11 08:37:01		2-SBT	Green	68	6-NBT	Green	68		
7/11 08:38:08		2-SBT			6-NBT				
7/11 08:38:09		2-SBT	Clear		6-NBT	Clear			
7/11 08:38:15		4-WBT	Green	15	8-EBT	Green	15		
7/11 08:38:30	1	4-WBT	Clear		8-EBT	Clear		Coord	
7/11 08:38:36		2-SBT	Green	73	6-NBT	Green	73		
7/11 08:39:48		2-SBT			6-NBT				
7/11 08:39:49		2-SBT	Clear		6-NBT	Clear			
7/11 08:39:55		4-WBT	Green	9	8-EBT	Green	9		
7/11 08:40:04	1	4-WBT	Clear		8-EBT	Clear		Coord	
7/11 08:40:10		2-SBT	Green	78	6-NBT	Green	78		
7/11 08:41:28		2-SBT	Clear		6-NBT	Clear			
7/11 08:41:35		4-WBT	Green	8	8-EBT	Green	8		
7/11 08:41:43	1	4-WBT	Clear		8-EBT	Clear		Coord	
7/11 08:41:49		2-SBT	Green	80	6-NBT	Green	80		
7/11 08:43:08		2-SBT			6-NBT				
7/11 08:43:09		2-SBT	Clear		6-NBT	Clear			
7/11 08:43:15		4-WBT	Green	20	8-EBT	Green	20		
7/11 08:43:35	1	4-WBT	Clear		8-EBT	Clear		Coord	
7/11 08:43:41		2-SBT	Green	68	6-NBT	Green	68		
7/11 08:44:48		2-SBT			6-NBT				

Historical Intersection Timing Report Int: Collins Av&16 St (5769)

Start Time: 7/11/25 08:20 End Time: 7/11/25 09:19

Print Date 07/11/2025

Print Time 11:55 AM

Time	Plan	Ring 1 Phase	Interval	Grn Dur	Ring 2 Phase	Interval	Grn Dur	Status	Poll Freq
7/11 08:44:49		2-SBT	Clear		6-NBT	Clear			
7/11 08:44:55		4-WBT	Green	12	8-EBT	Green	12		
7/11 08:45:07	1	4-WBT	Clear		8-EBT	Clear		Coord	
7/11 08:45:13		2-SBT	Green	76	6-NBT	Green	76		
7/11 08:46:28		2-SBT	Clear		6-NBT	Clear			
7/11 08:46:29		2-SBT	Clear		6-NBT	Clear			
7/11 08:46:35		4-WBT	Green	20	8-EBT	Green	20		
7/11 08:46:55	1	4-WBT	Clear		8-EBT	Clear		Coord	
7/11 08:47:01		2-SBT	Green	67	6-NBT	Green	67		
7/11 08:48:08		2-SBT	Clear		6-NBT	Clear			
7/11 08:48:15		4-WBT	Green	19	8-EBT	Green	19		
7/11 08:48:34	1	4-WBT	Clear		8-EBT	Clear		Coord	
7/11 08:48:40		2-SBT	Green	69	6-NBT	Green	69		
7/11 08:49:48		2-SBT	Clear		6-NBT	Clear			
7/11 08:49:49		2-SBT	Clear		6-NBT	Clear			
7/11 08:49:55		4-WBT	Green	22	8-EBT	Green	22		
7/11 08:50:17	1	4-WBT	Clear		8-EBT	Clear		Coord	
7/11 08:50:23		2-SBT	Green	66	6-NBT	Green	66		
7/11 08:51:28		2-SBT	Clear		6-NBT	Clear			
7/11 08:51:29		2-SBT	Clear		6-NBT	Clear			
7/11 08:51:35		4-WBT	Green	20	8-EBT	Green	20		
7/11 08:51:55	1	4-WBT	Clear		8-EBT	Clear		Coord	
7/11 08:52:01		2-SBT	Green	67	6-NBT	Green	67		
7/11 08:53:08		2-SBT	Clear		6-NBT	Clear			
7/11 08:53:15		4-WBT	Green	22	8-EBT	Green	22		
7/11 08:53:37	1	4-WBT	Clear		8-EBT	Clear		Coord	
7/11 08:53:43		2-SBT	Green	66	6-NBT	Green	66		
7/11 08:54:48		2-SBT	Clear		6-NBT	Clear			
7/11 08:54:49		2-SBT	Clear		6-NBT	Clear			
7/11 08:54:55		4-WBT	Green	20	8-EBT	Green	20		
7/11 08:55:15	1	4-WBT	Clear		8-EBT	Clear		Coord	
7/11 08:55:21		2-SBT	Green	68	6-NBT	Green	68		
7/11 08:56:28		2-SBT	Clear		6-NBT	Clear			
7/11 08:56:29		2-SBT	Clear		6-NBT	Clear			
7/11 08:56:35		4-WBT	Green	23	8-EBT	Green	23		
7/11 08:56:58	1	4-WBT	Clear		8-EBT	Clear		Coord	
7/11 08:57:04		2-SBT	Green	65	6-NBT	Green	65		
7/11 08:58:08		2-SBT	Clear		6-NBT	Clear			
7/11 08:58:09		2-SBT	Clear		6-NBT	Clear			
7/11 08:58:15		4-WBT	Green	20	8-EBT	Green	20		
7/11 08:58:35	1	4-WBT	Clear		8-EBT	Clear		Coord	
7/11 08:58:41		2-SBT	Green	67	6-NBT	Green	67		
7/11 08:59:48		2-SBT	Clear		6-NBT	Clear			
7/11 08:59:54		4-WBT	Green	22	8-EBT	Green	22		
7/11 09:00:16	1	4-WBT	Clear		8-EBT	Clear		Coord	
7/11 09:00:22		2-SBT	Green	66	6-NBT	Green	66		2
7/11 09:01:28		2-SBT	Clear		6-NBT	Clear			
7/11 09:01:35		4-WBT	Green	17	8-EBT	Green	17		
7/11 09:01:52	1	4-WBT	Clear		8-EBT	Clear		Coord	
7/11 09:01:58		2-SBT	Green	71	6-NBT	Green	71		
7/11 09:03:08		2-SBT	Clear		6-NBT	Clear			
7/11 09:03:09		2-SBT	Clear		6-NBT	Clear			
7/11 09:03:15		4-WBT	Green	13	8-EBT	Green	13		
7/11 09:03:28	1	4-WBT	Clear		8-EBT	Clear		Coord	
7/11 09:03:34		2-SBT	Green	74	6-NBT	Green	74		
7/11 09:04:48		2-SBT	Clear		6-NBT	Clear			
7/11 09:04:55		4-WBT	Green	19	8-EBT	Green	19		
7/11 09:05:14	1	4-WBT	Clear		8-EBT	Clear		Coord	
7/11 09:05:20		2-SBT	Green	68	6-NBT	Green	68		
7/11 09:06:28		2-SBT	Clear		6-NBT	Clear			
7/11 09:06:35		4-WBT	Green	22	8-EBT	Green	22		
7/11 09:06:57	1	4-WBT	Clear		8-EBT	Clear		Coord	
7/11 09:07:04		2-SBT	Green	64	6-NBT	Green	64		
7/11 09:08:08		2-SBT	Clear		6-NBT	Clear			
7/11 09:08:15		4-WBT	Green	9	8-EBT	Green	9		
7/11 09:08:24	1	4-WBT	Clear		8-EBT	Clear		Coord	

Historical Intersection Timing Report Int: Collins Av&16 St (5769)

Start Time: 7/11/25 08:20 End Time: 7/11/25 09:19

Print Date 07/11/2025

Print Time 11:55 AM

<u>Time</u>	<u>Plan</u>	<u>Ring 1 Phase</u>	<u>Interval</u>	<u>Grn Dur</u>	<u>Ring 2 Phase</u>	<u>Interval</u>	<u>Grn Dur</u>	<u>Status</u>	<u>Poll Freq</u>
7/11 09:08:30		2-SBT	Green	79	6-NBT	Green	79		
7/11 09:09:48		2-SBT			6-NBT				
7/11 09:09:49		2-SBT	Clear		6-NBT	Clear			
7/11 09:09:55		4-WBT	Green	20	8-EBT	Green	20		
7/11 09:10:15	1	4-WBT	Clear		8-EBT	Clear		Coord	
7/11 09:10:21		2-SBT	Green	67	6-NBT	Green	67		
7/11 09:11:28		2-SBT	Clear		6-NBT	Clear			
7/11 09:11:34		4-WBT	Green	21	8-EBT	Green	21		
7/11 09:11:55	1	4-WBT	Clear		8-EBT	Clear		Coord	
7/11 09:12:01		2-SBT	Green	68	6-NBT	Green	68		
7/11 09:13:08		2-SBT			6-NBT				
7/11 09:13:09		2-SBT	Clear		6-NBT	Clear			
7/11 09:13:15		4-WBT	Green	20	8-EBT	Green	20		
7/11 09:13:35	1	4-WBT	Clear		8-EBT	Clear		Coord	
7/11 09:13:41		2-SBT	Green	68	6-NBT	Green	68		
7/11 09:14:48		2-SBT			6-NBT				
7/11 09:14:49		2-SBT	Clear		6-NBT	Clear			
7/11 09:14:55		4-WBT	Green	20	8-EBT	Green	20		
7/11 09:15:15	1	4-WBT	Clear		8-EBT	Clear		Coord	
7/11 09:15:21		2-SBT	Green	68	6-NBT	Green	68		
7/11 09:16:28		2-SBT			6-NBT				
7/11 09:16:29		2-SBT	Clear		6-NBT	Clear			
7/11 09:16:35		4-WBT	Green	20	8-EBT	Green	20		
7/11 09:16:55	1	4-WBT	Clear		8-EBT	Clear		Coord	
7/11 09:17:01		2-SBT	Green	67	6-NBT	Green	67		
7/11 09:18:08		2-SBT	Clear		6-NBT	Clear			
7/11 09:18:15		4-WBT	Green	7	8-EBT	Green	7		
7/11 09:18:22	1	4-WBT	Clear		8-EBT	Clear		Coord	
7/11 09:18:28		2-SBT	Green	81	6-NBT	Green	81		

Summary

Plan: 1 Start Time: 7/11 08:20:10 End Time: 7/11 09:19:48

Cycle:100 Offset:89

Phases in use: 1 2-SBT 3 4-WBT 5 6-NBT 7 8-EBT
 Splits 0 70 0 30 0 70 0 30

Overlaps in use: A:A LOADSW 0 B:B LOADSW 0 C:C LOADSW 0 D:D LOADSW 0 E:E
 LOADSW 0 F:F LOADSW 0 G:G LOADSW 0 H:H LOADSW 0

Number of full cycles in period: 56
 Number of preempts: EV: 0 RR: 0 Spec Events: 0
 Number of comm. failures: 0
 Number of gaps in poll messages: 0
 Number of Busway services: 0
 Number of Low Priority services: 0

Phase	1	2	3	4	5	6	7	8
Actuation	0	56	0	35	0	56	0	35
Omits	56	0	56	21	56	0	56	21
Max Out	0	35	0	0	0	35	0	0
Min Svc	0	21	0	3	0	21	0	3
Avg Grn	0.0	44.2	0.0	16.8	0.0	44.2	0.0	16.8
Min Grn	0	1	0	7	0	1	0	7
Max Grn	0	80	0	23	0	80	0	23
Std. Dev	0.0	34.0	0.0	5.3	0.0	34.0	0.0	5.3
Avg G/C(%)	0	70.8	0	16.8	0	70.8	0	16.8



RE: Request for Updated Signal Timing and SOP Reports – Drexel Ave & 16th St -2707 / Collins Ave & 16th St 5769

From Hernandez, Mario (DTPW) <marioih@miamidade.gov>

Date Fri 7/11/2025 4:09 PM

To Adriana Rodriguez <beacontraffice@outlook.com>

 6 attachments (1 MB)

2707-800-to-900-hitreport.pdf; 5769-800-to-900-hitreport.pdf; Asset 5769 Current.pdf; SOP 2707.pdf; SOP 5769.pdf; SOP+SIGNAL PLAN 2707.pdf;

Good morning, Ms. Rodriguez.

My comments are written in **brown** aside of your questions.

Document requested attached for your references.

Regards.

Mario Luis Hernandez
Traffic Engineer II, Traffic Signals and Signs Division
Miami-Dade County Department of Transportation and Public Works
7100 NW 36th Street
Miami, Florida 33166
305-679-0032 Phone
786-747-6084 Cell



miamidade.gov/transportation

Connect With Us on [Twitter](#) | [Facebook](#) | [Instagram](#)

From: Adriana Rodriguez <beacontraffice@outlook.com>

Sent: Wednesday, July 9, 2025 9:07 PM

To: Hernandez, Mario (DTPW) <marioih@miamidade.gov>

Cc: Joaquin Vargas <joaquin@traftech.biz>; Adriana <adrianadelpilar.rodriguez@yahoo.com>

Subject: Request for Updated Signal Timing and SOP Reports – Drexel Ave & 16th St / Collins Ave & 16th St

You don't often get email from beacontraffice@outlook.com. [Learn why this is important](#)

EMAIL RECEIVED FROM EXTERNAL SOURCE

Good morning Mr. Hernandez

I am reaching out regarding recent comments received from the City of Miami Beach Traffic Consultant indicating that exclusive pedestrian phases are currently present at the intersections of **Drexel Avenue & 16th Street** and **Collins Avenue & 16th Street**. Specifically, the consultant noted that:

- The Drexel Avenue & 16th Street **Asset # 2707** intersection includes an exclusive pedestrian phase operating during the weekday A.M. peak hour. Exclusive Pedestrian operation from 8:00 to 9:00 in the morning and from 13:30 to 15:30 in the afternoon.
- The Collins Avenue & 16th Street **Asset # 5769** intersection includes exclusive pedestrian phases operating during both A.M. and P.M. peak periods. **NO**

To verify this information, I reviewed the latest available signal timing sheets and SOP plans from the Miami-Dade County Traffic Signal Documents Portal, and based on that review, I did not find any documentation confirming the presence of exclusive pedestrian phases at either intersection.

I kindly request your assistance in:

1. Providing the **most updated signal timing and SOP reports** for these two intersections.
2. Confirming whether exclusive pedestrian phases are currently programmed or planned.

Thank you very much for your time and support.

Adriana Rodriguez, P.E., PTOE

Beacon Traffic Consulting, Inc.

APPENDIX D

**Peak Season Conversion Factors,
Historical Traffic Data, Growth Rate
Analysis, and Committed Developments**

2024 PEAK SEASON FACTOR CATEGORY REPORT - REPORT TYPE: ALL
 CATEGORY: 8700 MIAMI-DADE NORTH

WEEK	DATES	SF	MOCF: 0.95 PSCF
1	01/01/2024 - 01/06/2024	1.07	1.13
2	01/07/2024 - 01/13/2024	1.03	1.08
3	01/14/2024 - 01/20/2024	1.00	1.05
4	01/21/2024 - 01/27/2024	0.98	1.03
* 5	01/28/2024 - 02/03/2024	0.97	1.02
* 6	02/04/2024 - 02/10/2024	0.96	1.01
* 7	02/11/2024 - 02/17/2024	0.95	1.00
* 8	02/18/2024 - 02/24/2024	0.95	1.00
* 9	02/25/2024 - 03/02/2024	0.94	0.99
*10	03/03/2024 - 03/09/2024	0.94	0.99
*11	03/10/2024 - 03/16/2024	0.94	0.99
*12	03/17/2024 - 03/23/2024	0.94	0.99
*13	03/24/2024 - 03/30/2024	0.95	1.00
*14	03/31/2024 - 04/06/2024	0.95	1.00
*15	04/07/2024 - 04/13/2024	0.96	1.01
*16	04/14/2024 - 04/20/2024	0.97	1.02
*17	04/21/2024 - 04/27/2024	0.98	1.03
18	04/28/2024 - 05/04/2024	0.99	1.04
19	05/05/2024 - 05/11/2024	1.00	1.05
20	05/12/2024 - 05/18/2024	1.02	1.07
21	05/19/2024 - 05/25/2024	1.03	1.08
22	05/26/2024 - 06/01/2024	1.04	1.09
23	06/02/2024 - 06/08/2024	1.05	1.11
24	06/09/2024 - 06/15/2024	1.06	1.12
25	06/16/2024 - 06/22/2024	1.05	1.11
26	06/23/2024 - 06/29/2024	1.04	1.09
27	06/30/2024 - 07/06/2024	1.03	1.08
28	07/07/2024 - 07/13/2024	1.02	1.07
29	07/14/2024 - 07/20/2024	1.02	1.07
30	07/21/2024 - 07/27/2024	1.01	1.06
31	07/28/2024 - 08/03/2024	1.01	1.06
32	08/04/2024 - 08/10/2024	1.01	1.06
33	08/11/2024 - 08/17/2024	1.01	1.06
34	08/18/2024 - 08/24/2024	1.01	1.06
35	08/25/2024 - 08/31/2024	1.01	1.06
36	09/01/2024 - 09/07/2024	1.01	1.06
37	09/08/2024 - 09/14/2024	1.01	1.06
38	09/15/2024 - 09/21/2024	1.01	1.06
39	09/22/2024 - 09/28/2024	1.01	1.06
40	09/29/2024 - 10/05/2024	1.01	1.06
41	10/06/2024 - 10/12/2024	1.01	1.06
42	10/13/2024 - 10/19/2024	1.02	1.07
43	10/20/2024 - 10/26/2024	1.02	1.07
44	10/27/2024 - 11/02/2024	1.02	1.07
45	11/03/2024 - 11/09/2024	1.02	1.07
46	11/10/2024 - 11/16/2024	1.03	1.08
47	11/17/2024 - 11/23/2024	1.03	1.08
48	11/24/2024 - 11/30/2024	1.04	1.09
49	12/01/2024 - 12/07/2024	1.05	1.11
50	12/08/2024 - 12/14/2024	1.06	1.12
51	12/15/2024 - 12/21/2024	1.07	1.13
52	12/22/2024 - 12/28/2024	1.03	1.08
53	12/29/2024 - 12/31/2024	1.00	1.05

* PEAK SEASON

FLORIDA DEPARTMENT OF TRANSPORTATION
TRANSPORTATION STATISTICS OFFICE
2024 HISTORICAL AADT REPORT

COUNTY: 87 - MIAMI-DADE

SITE: 8414 - WASHINGTON AVE, 200 FT N OF 12 ST (2011 OFF SYSTEM CYCLE)

YEAR	AADT		DIRECTION 1		DIRECTION 2	*K FACTOR	D FACTOR	T FACTOR	
2024	14600	C	N	7000	S	7600	9.00	52.70	3.60
2023	15400	C	N	7000	S	8400	9.00	63.10	4.30
2022	15100	C	N	7000	S	8100	9.00	56.50	4.20
2021	14200	C	N	6500	S	7700	9.00	55.00	3.30
2020	14100	C	N	7100	S	7000	9.00	56.00	10.70
2019	23000	C	N	11000	S	12000	9.00	56.00	2.40
2018	20400	C	N	11500	S	8900	9.00	54.30	2.50
2017	20200	C	N	9200	S	11000	9.00	59.30	2.40
2016	20800	C	N	9800	S	11000	9.00	56.10	1.90
2015	20300	C	N	9800	S	10500	9.00	57.40	17.50
2014	21000	C	N	10000	S	11000	9.00	59.30	13.90
2013	18700	F	N	9200	S	9500	9.00	58.90	16.20
2012	18700	C	N	9200	S	9500	9.00	59.70	16.00

AADT FLAGS: C = COMPUTED; E = MANUAL ESTIMATE; F = FIRST YEAR ESTIMATE
S = SECOND YEAR ESTIMATE; T = THIRD YEAR ESTIMATE; R = FOURTH YEAR ESTIMATE
V = FIFTH YEAR ESTIMATE; 6 = SIXTH YEAR ESTIMATE; X = UNKNOWN

*K FACTOR: STARTING WITH YEAR 2011 IS STANDARDK, PRIOR YEARS ARE K30 VALUES

FLORIDA DEPARTMENT OF TRANSPORTATION
TRANSPORTATION STATISTICS OFFICE
2024 HISTORICAL AADT REPORT

COUNTY: 87 - MIAMI-DADE

SITE: 8567 - 16 ST, 200' EAST OF MERIDIAN AVE (2011 OFF SYSTEM CYCLE)

YEAR	AADT		DIRECTION 1		DIRECTION 2	*K FACTOR	D FACTOR	T FACTOR	
2024	6400	F	E	3200	W	3200	9.00	52.70	3.80
2023	6400	C	E	3200	W	3200	9.00	63.10	3.70
2022	4700	T	E	2300	W	2400	9.00	56.50	3.50
2021	4500	S	E	2200	W	2300	9.00	55.00	2.90
2020	4700	F	E	2300	W	2400	9.00	56.00	4.40
2019	5300	C	E	2600	W	2700	9.00	56.00	4.00
2018	7800	T	E	3800	W	4000	9.00	54.30	3.00
2017	8700	S	E	4200	W	4500	9.00	59.30	2.50
2016	8900	F	E	4300	W	4600	9.00	56.10	5.10
2015	9100	C	E	4400	W	4700	9.00	57.40	7.10
2014	9700	S					9.00	59.30	10.70
2013	9800	F		0		0	9.00	58.90	16.20
2012	9900	C	E	0	W	0	9.00	59.70	16.00

AADT FLAGS: C = COMPUTED; E = MANUAL ESTIMATE; F = FIRST YEAR ESTIMATE
S = SECOND YEAR ESTIMATE; T = THIRD YEAR ESTIMATE; R = FOURTH YEAR ESTIMATE
V = FIFTH YEAR ESTIMATE; 6 = SIXTH YEAR ESTIMATE; X = UNKNOWN

*K FACTOR: STARTING WITH YEAR 2011 IS STANDARDK, PRIOR YEARS ARE K30 VALUES

Traffic Trends - V03.a

WASHINGTON AVE -- 200 FT N OF 12 ST (2011 OFF SYSTEM CYCLE)

FIN#	1234
Location	1

County:	Miami-Dade (87)
Station #:	8414
Highway:	WASHINGTON AVE

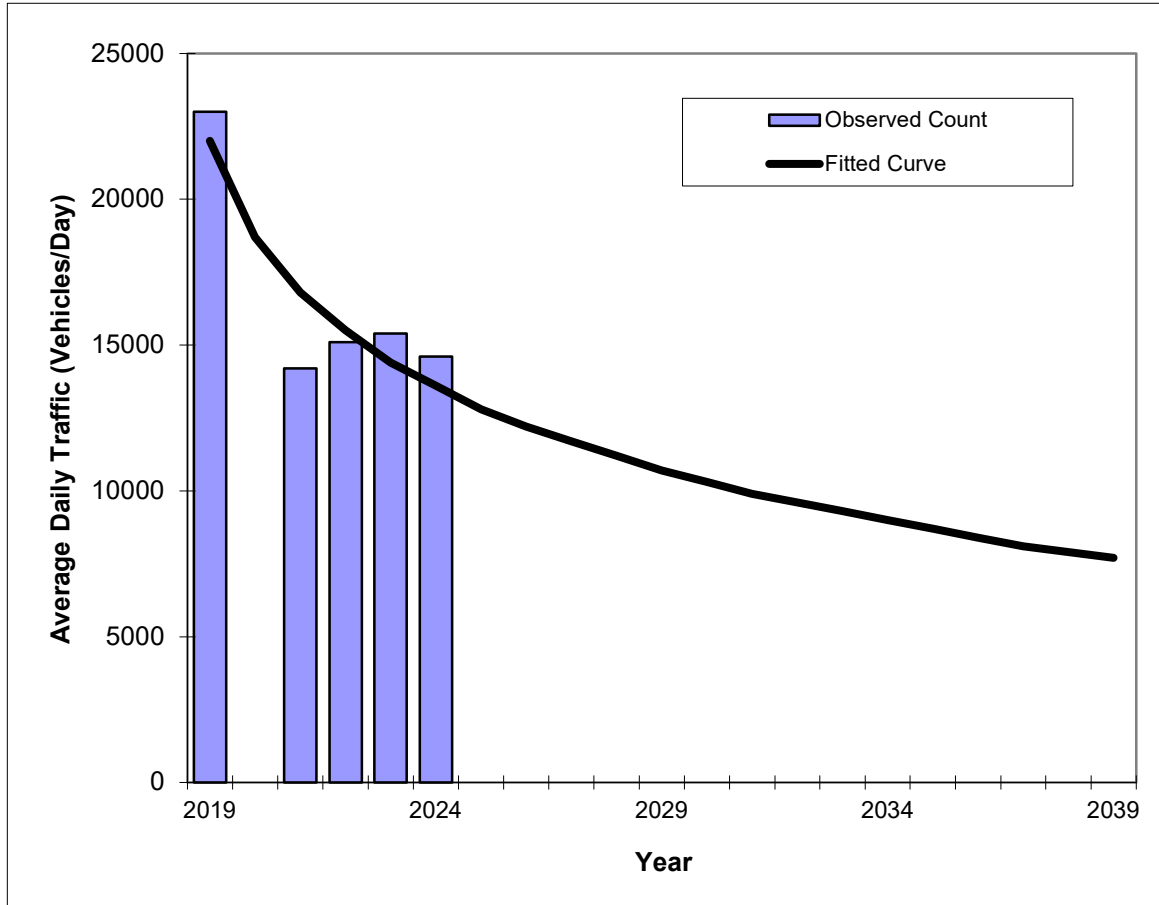

Year	Traffic (ADT/AADT)	
	Count*	Trend**
2019	23000	22000
2020	N/A	N/A
2021	14200	16800
2022	15100	15500
2023	15400	14400
2024	14600	13600
2025 Opening Year Trend		
2025	N/A	12800
2026 Mid-Year Trend		
2026	N/A	12200
2028 Design Year Trend		
2028	N/A	11200
TRANPLAN Forecasts/Trends		

Trend R-squared:	81.46%
Compounded Annual Historic Growth Rate:	-9.17%
Compounded Growth Rate (2024 to Design Year):	-4.74%
Printed:	18-Jun-25
Decaying Exponential Growth Option	

*Axle-Adjusted

Traffic Trends - V03.a

WASHINGTON AVE -- 200 FT N OF 12 ST (2011 OFF SYSTEM CYCLE)

FIN#	1234
Location	1

County:	Miami-Dade (87)
Station #:	8414
Highway:	WASHINGTON AVE

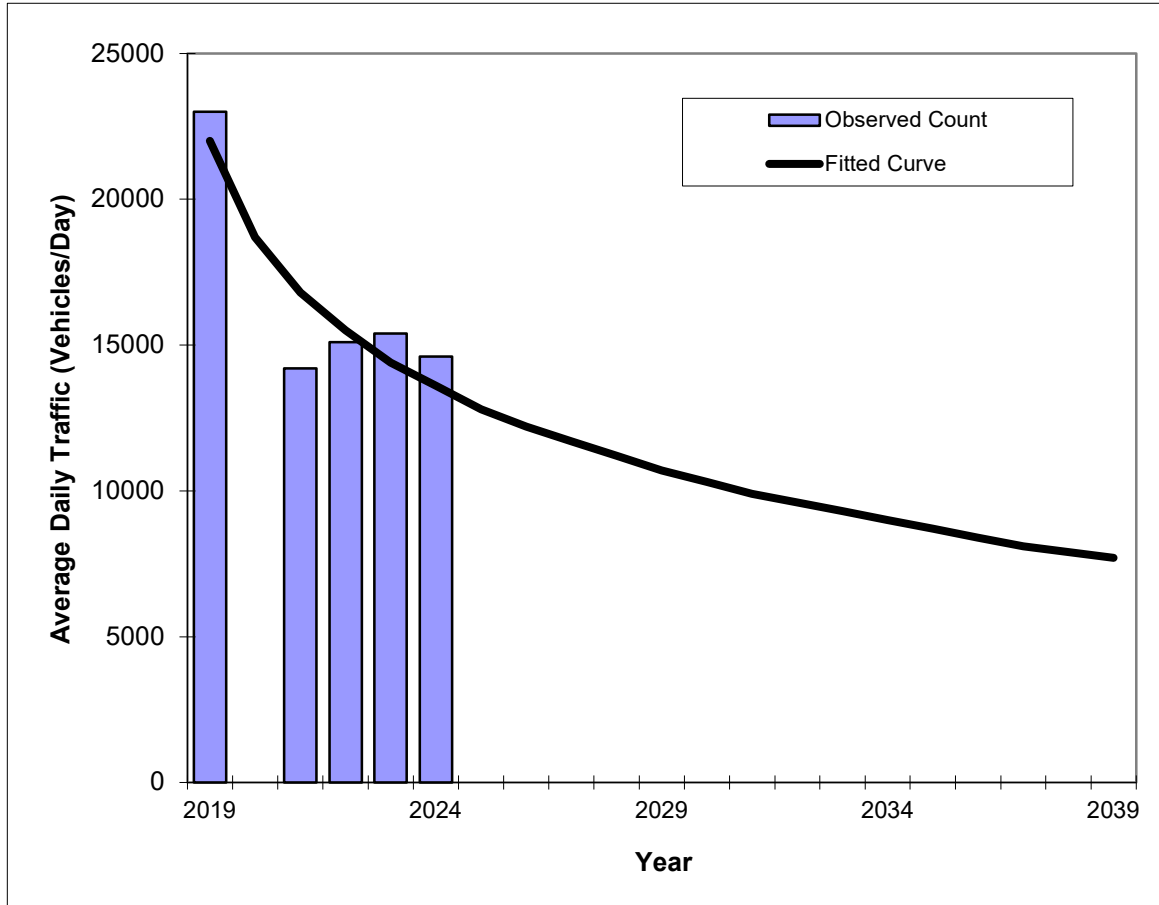

Year	Traffic (ADT/AADT)	
	Count*	Trend**
2019	23000	22000
2020	N/A	N/A
2021	14200	16800
2022	15100	15500
2023	15400	14400
2024	14600	13600
2025 Opening Year Trend		
2025	N/A	12800
2026 Mid-Year Trend		
2026	N/A	12200
2028 Design Year Trend		
2028	N/A	11200
TRANPLAN Forecasts/Trends		

Trend R-squared:	59.31%
Compounded Annual Historic Growth Rate:	-9.17%
Compounded Growth Rate (2024 to Design Year):	-4.74%
Printed:	18-Jun-25
Exponential Growth Option	

*Axle-Adjusted

Traffic Trends - V03.a

WASHINGTON AVE -- 200 FT N OF 12 ST (2011 OFF SYSTEM CYCLE)

FIN#	1234
Location	1

County:	Miami-Dade (87)
Station #:	8414
Highway:	WASHINGTON AVE

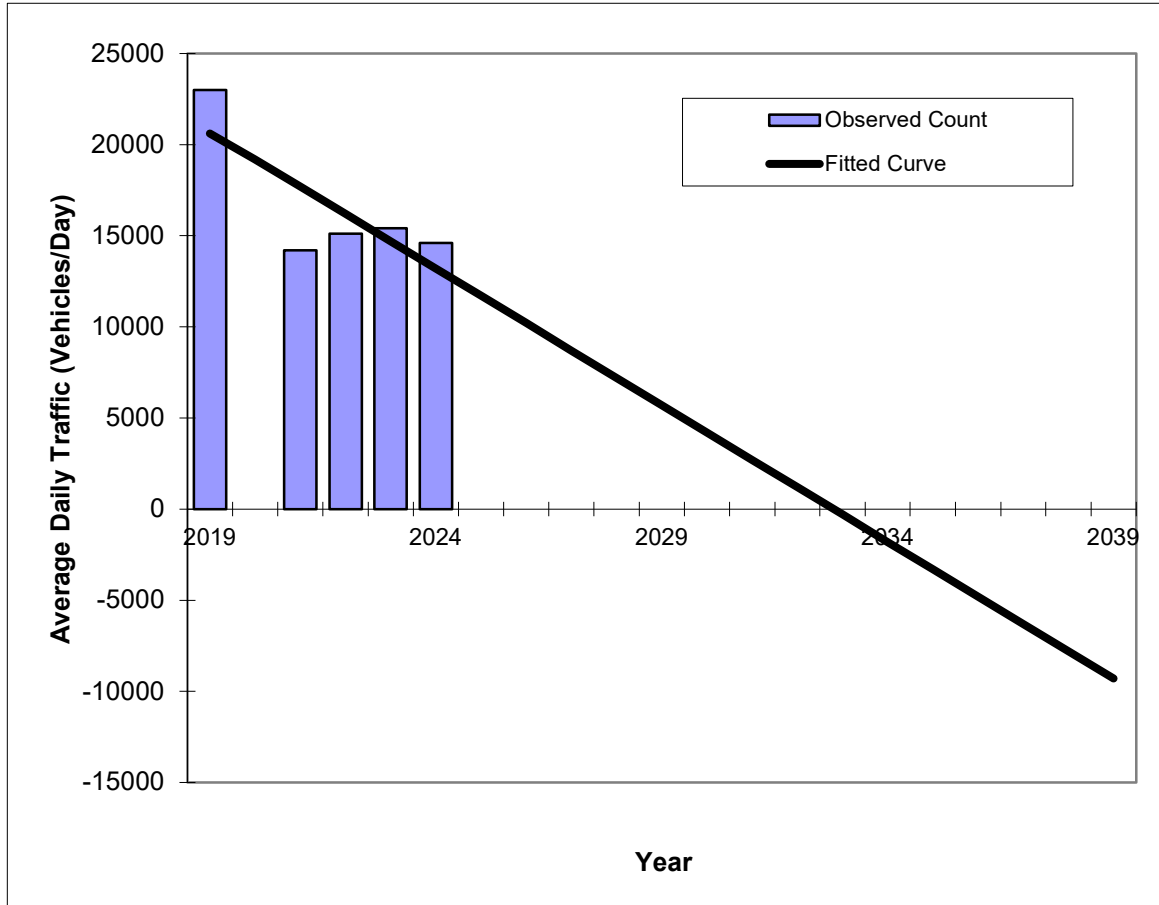

Year	Traffic (ADT/AADT)	
	Count*	Trend**
2019	23000	20600
2020	N/A	N/A
2021	14200	17700
2022	15100	16200
2023	15400	14700
2024	14600	13200
2025 Opening Year Trend		
2025	N/A	11700
2026 Mid-Year Trend		
2026	N/A	10200
2028 Design Year Trend		
2028	N/A	7200
TRANPLAN Forecasts/Trends		

** Annual Trend Increase:	-1,496
Trend R-squared:	60.98%
Trend Annual Historic Growth Rate:	-7.18%
Trend Growth Rate (2024 to Design Year):	-11.36%
Printed:	18-Jun-25
Straight Line Growth Option	

*Axle-Adjusted

Traffic Trends - V03.a

WASHINGTON AVE -- 200 FT N OF 12 ST (2011 OFF SYSTEM CYCLE)

FIN#	1234
Location	1

County:	Miami-Dade (87)
Station #:	8414
Highway:	WASHINGTON AVE

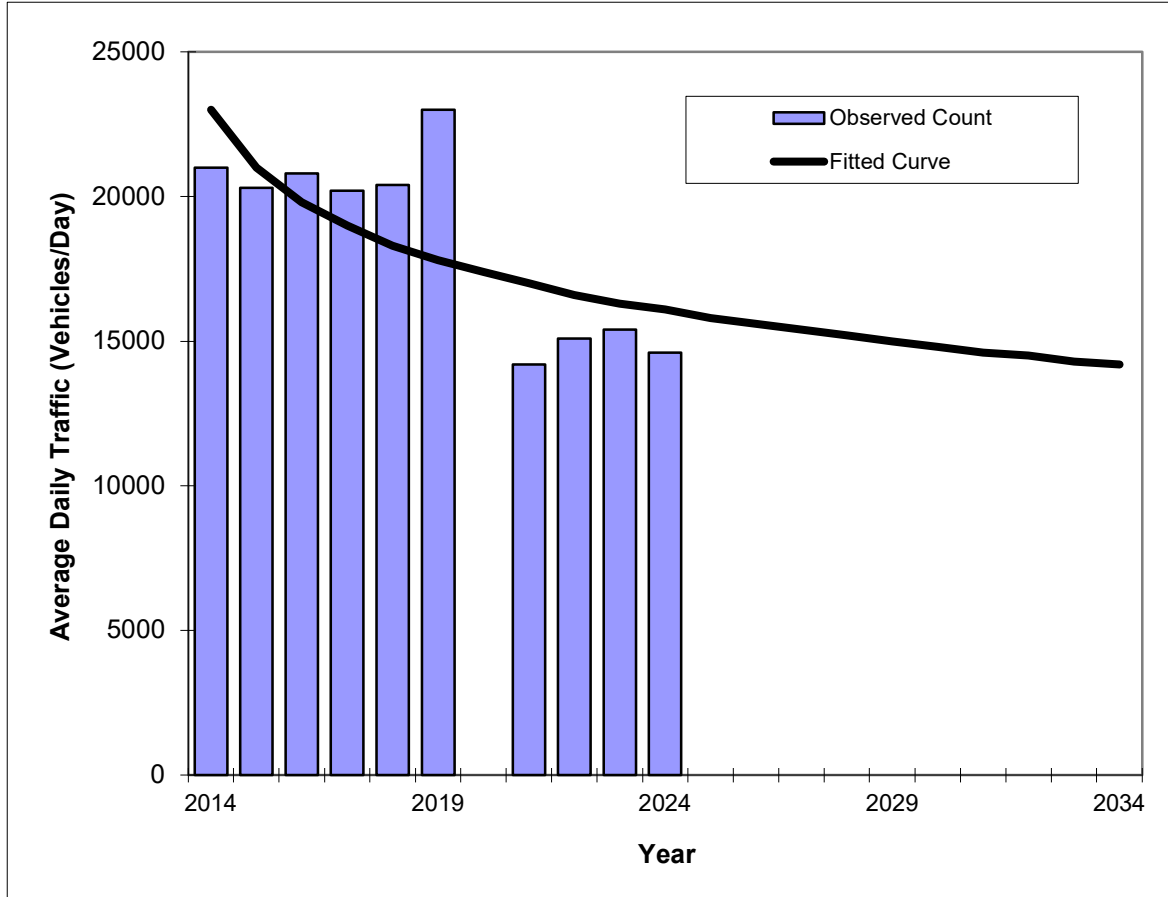

Year	Traffic (ADT/AADT)	
	Count*	Trend**
2014	21000	23000
2015	20300	21000
2016	20800	19800
2017	20200	19000
2018	20400	18300
2019	23000	17800
2020	N/A	N/A
2021	14200	17000
2022	15100	16600
2023	15400	16300
2024	14600	16100
2025 Opening Year Trend		
2025	N/A	15800
2026 Mid-Year Trend		
2026	N/A	15600
2028 Design Year Trend		
2028	N/A	15200
TRANPLAN Forecasts/Trends		

Trend R-squared:	46.93%
Compounded Annual Historic Growth Rate:	-3.50%
Compounded Growth Rate (2024 to Design Year):	-1.43%
Printed:	18-Jun-25
Decaying Exponential Growth Option	

*Axle-Adjusted

Traffic Trends - V03.a

WASHINGTON AVE -- 200 FT N OF 12 ST (2011 OFF SYSTEM CYCLE)

FIN#	1234
Location	1

County:	Miami-Dade (87)
Station #:	8414
Highway:	WASHINGTON AVE

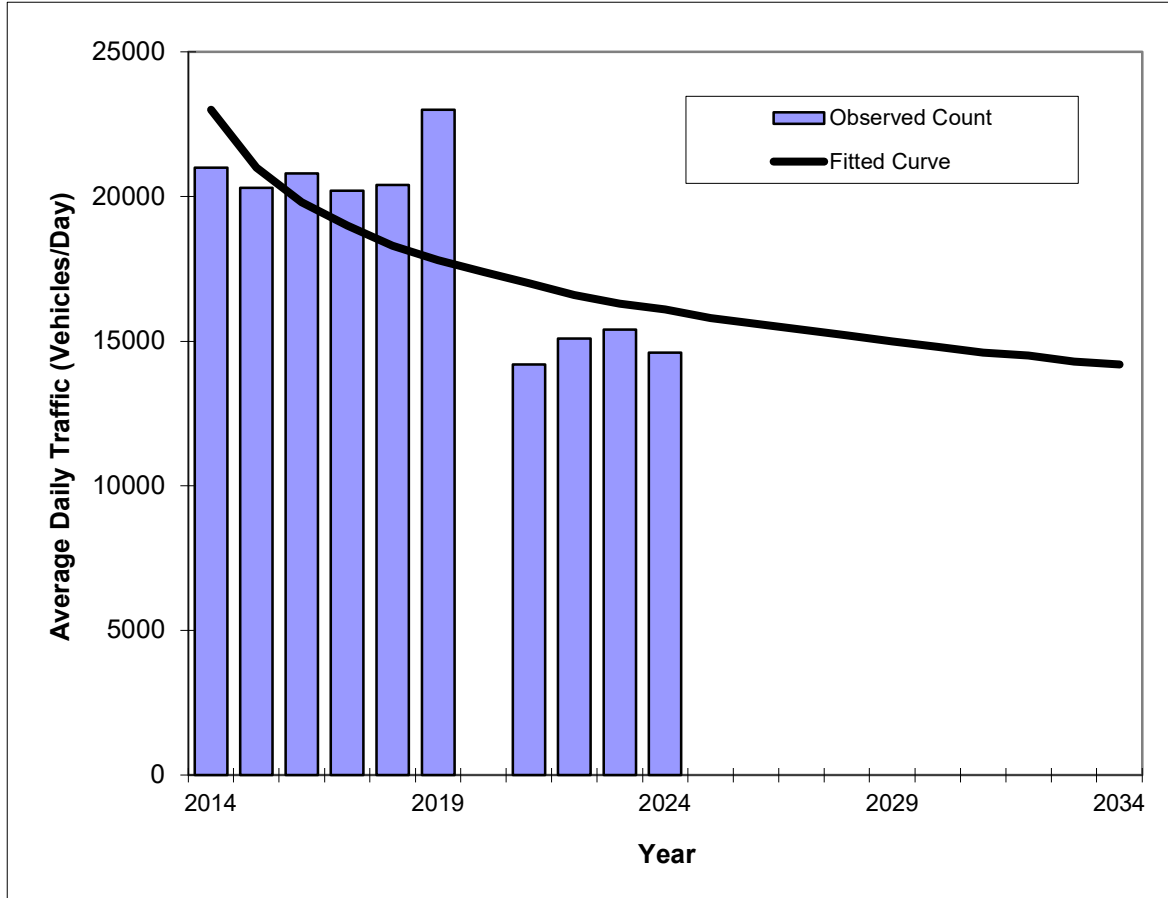

Year	Traffic (ADT/AADT)	
	Count*	Trend**
2014	21000	23000
2015	20300	21000
2016	20800	19800
2017	20200	19000
2018	20400	18300
2019	23000	17800
2020	N/A	N/A
2021	14200	17000
2022	15100	16600
2023	15400	16300
2024	14600	16100
2025 Opening Year Trend		
2025	N/A	15800
2026 Mid-Year Trend		
2026	N/A	15600
2028 Design Year Trend		
2028	N/A	15200
TRANPLAN Forecasts/Trends		

Trend R-squared:	67.22%
Compounded Annual Historic Growth Rate:	-3.50%
Compounded Growth Rate (2024 to Design Year):	-1.43%
Printed:	18-Jun-25
Exponential Growth Option	

*Axle-Adjusted

Traffic Trends - V03.a

WASHINGTON AVE -- 200 FT N OF 12 ST (2011 OFF SYSTEM CYCLE)

FIN#	1234
Location	1

County:	Miami-Dade (87)
Station #:	8414
Highway:	WASHINGTON AVE

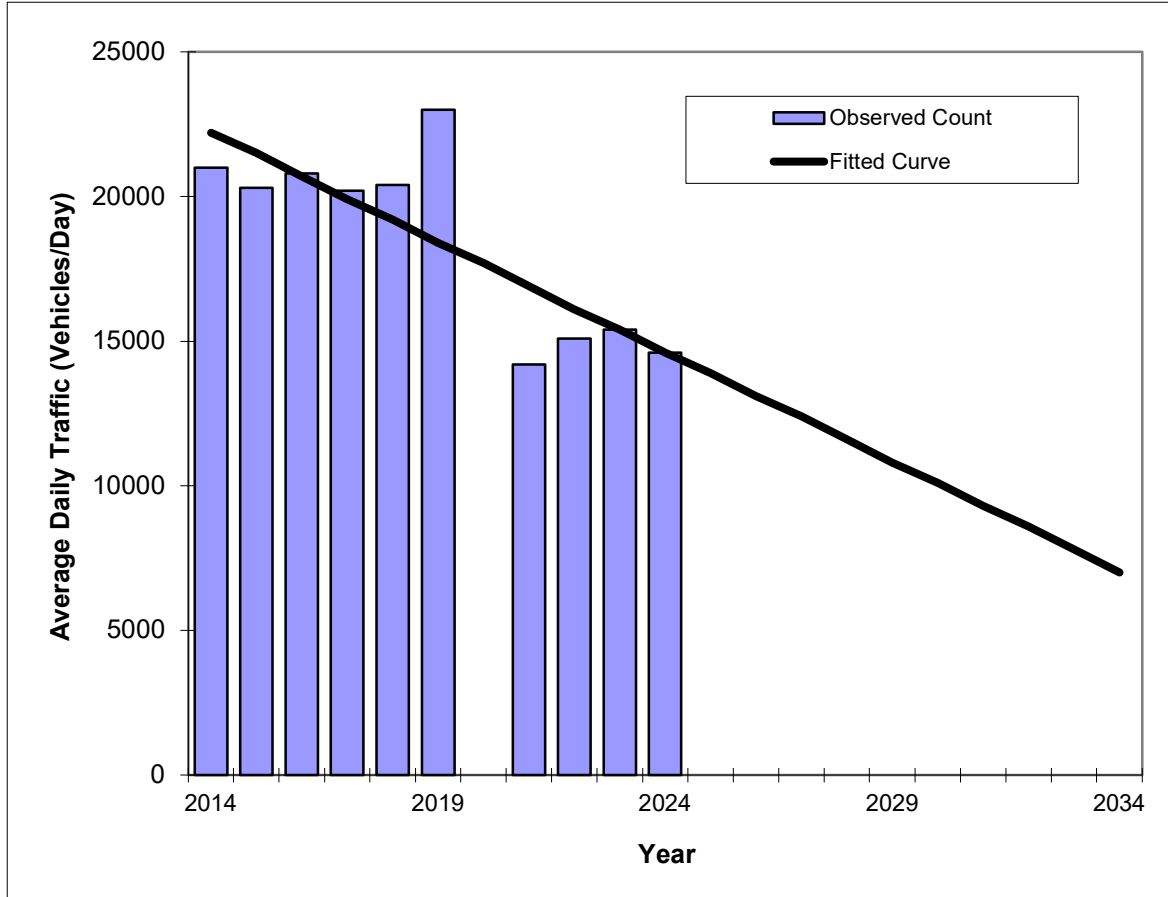

Year	Traffic (ADT/AADT)	
	Count*	Trend**
2014	21000	22200
2015	20300	21500
2016	20800	20700
2017	20200	19900
2018	20400	19200
2019	23000	18400
2020	N/A	N/A
2021	14200	16900
2022	15100	16100
2023	15400	15400
2024	14600	14600
2025 Opening Year Trend		
2025	N/A	13900
2026 Mid-Year Trend		
2026	N/A	13100
2028 Design Year Trend		
2028	N/A	11600
TRANPLAN Forecasts/Trends		

** Annual Trend Increase:	-758
Trend R-squared:	64.99%
Trend Annual Historic Growth Rate:	-3.42%
Trend Growth Rate (2024 to Design Year):	-5.14%
Printed:	18-Jun-25
Straight Line Growth Option	

*Axle-Adjusted

Traffic Trends - V03.a

16 ST -- 200' EAST OF MERIDIAN AVE (2011 OFF SYSTEM CYCLE)

FIN#	1234
Location	2

County:	Miami-Dade (87)
Station #:	8567
Highway:	16 ST

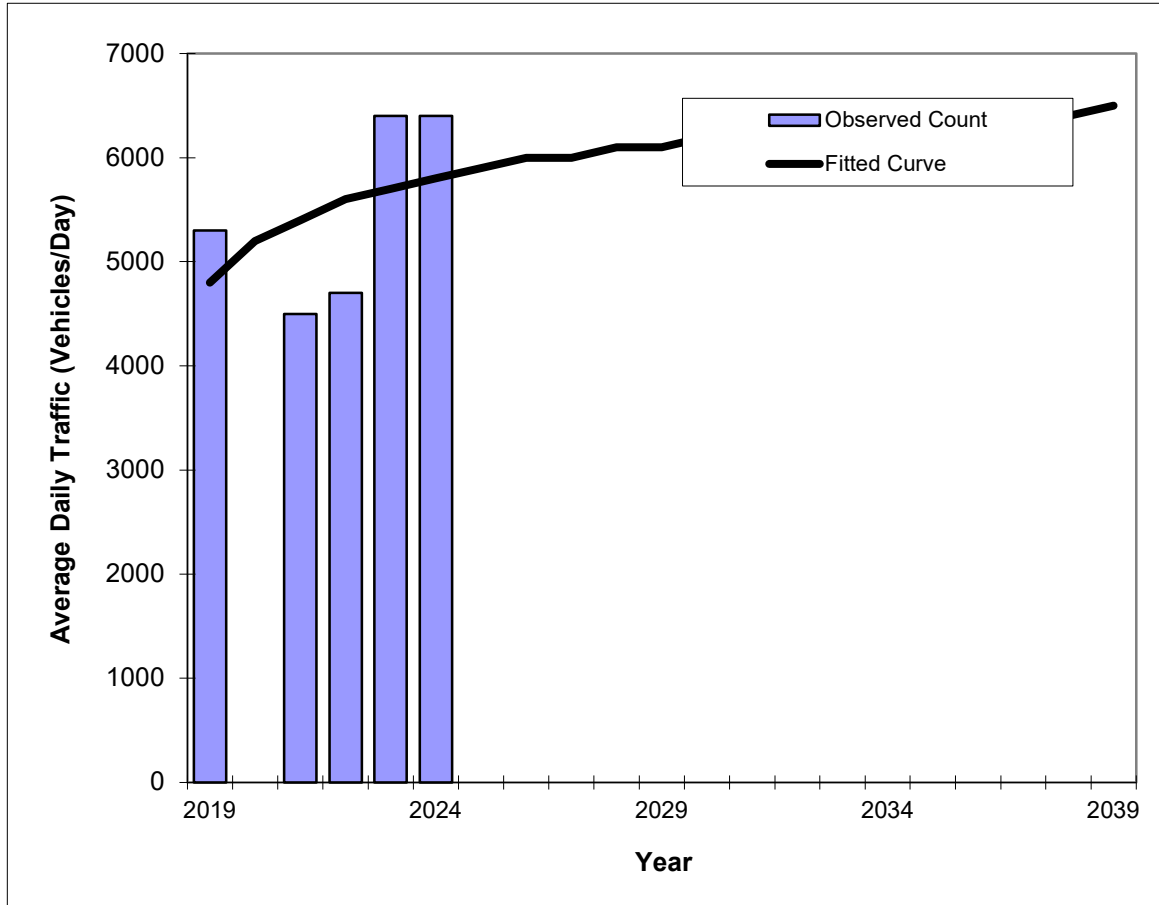

Year	Traffic (ADT/AADT)	
	Count*	Trend**
2019	5300	4800
2020	N/A	N/A
2021	4500	5400
2022	4700	5600
2023	6400	5700
2024	6400	5800
2025 Opening Year Trend		
2025	N/A	5900
2026 Mid-Year Trend		
2026	N/A	6000
2028 Design Year Trend		
2028	N/A	6100
TRANPLAN Forecasts/Trends		

Trend R-squared:	18.01%
Compounded Annual Historic Growth Rate:	3.86%
Compounded Growth Rate (2024 to Design Year):	1.27%
Printed:	18-Jun-25
Decaying Exponential Growth Option	

*Axle-Adjusted

Traffic Trends - V03.a

16 ST -- 200' EAST OF MERIDIAN AVE (2011 OFF SYSTEM CYCLE)

FIN#	1234
Location	2

County:	Miami-Dade (87)
Station #:	8567
Highway:	16 ST

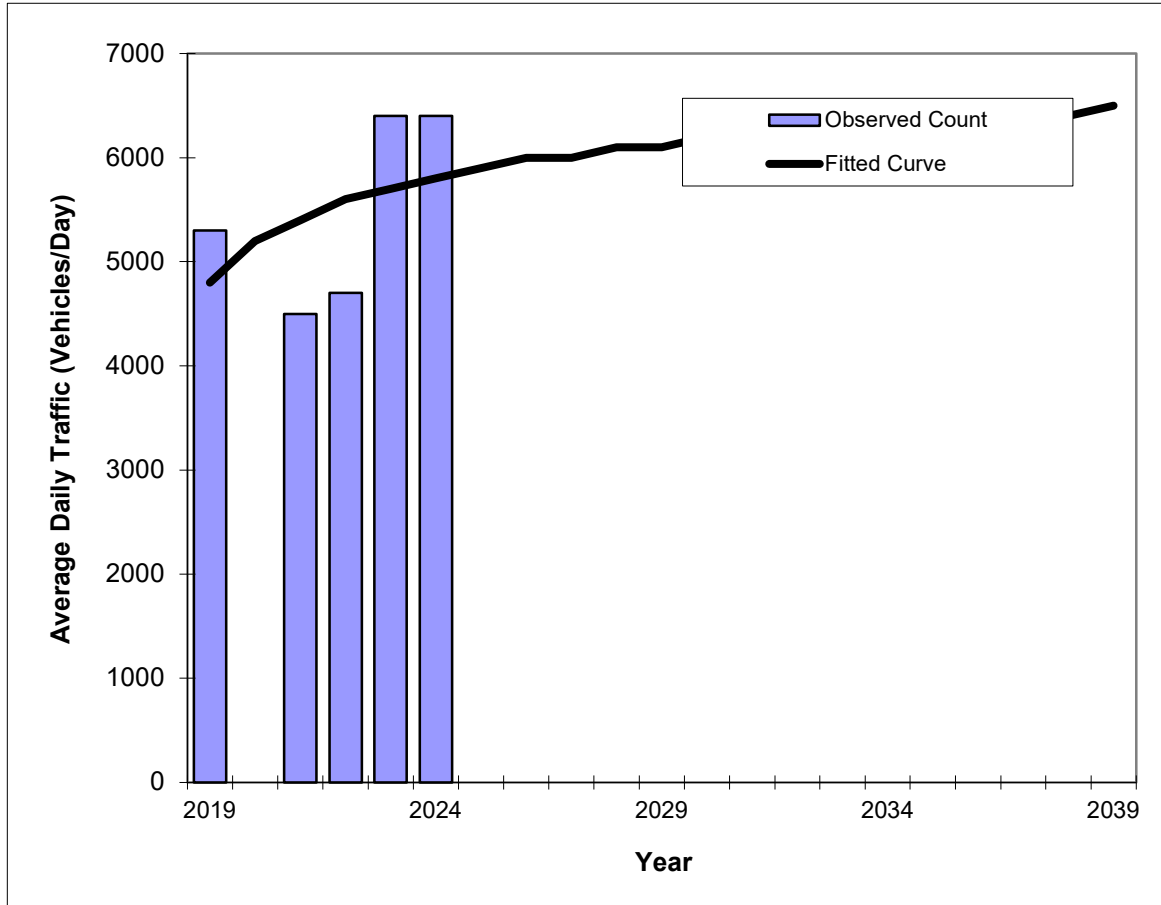

Year	Traffic (ADT/AADT)	
	Count*	Trend**
2019	5300	4800
2020	N/A	N/A
2021	4500	5400
2022	4700	5600
2023	6400	5700
2024	6400	5800
2025 Opening Year Trend		
2025	N/A	5900
2026 Mid-Year Trend		
2026	N/A	6000
2028 Design Year Trend		
2028	N/A	6100
TRANPLAN Forecasts/Trends		

Trend R-squared:	34.19%
Compounded Annual Historic Growth Rate:	3.86%
Compounded Growth Rate (2024 to Design Year):	1.27%
Printed:	18-Jun-25
Exponential Growth Option	

*Axle-Adjusted

Traffic Trends - V03.a

16 ST -- 200' EAST OF MERIDIAN AVE (2011 OFF SYSTEM CYCLE)

FIN#	1234
Location	2

County:	Miami-Dade (87)
Station #:	8567
Highway:	16 ST

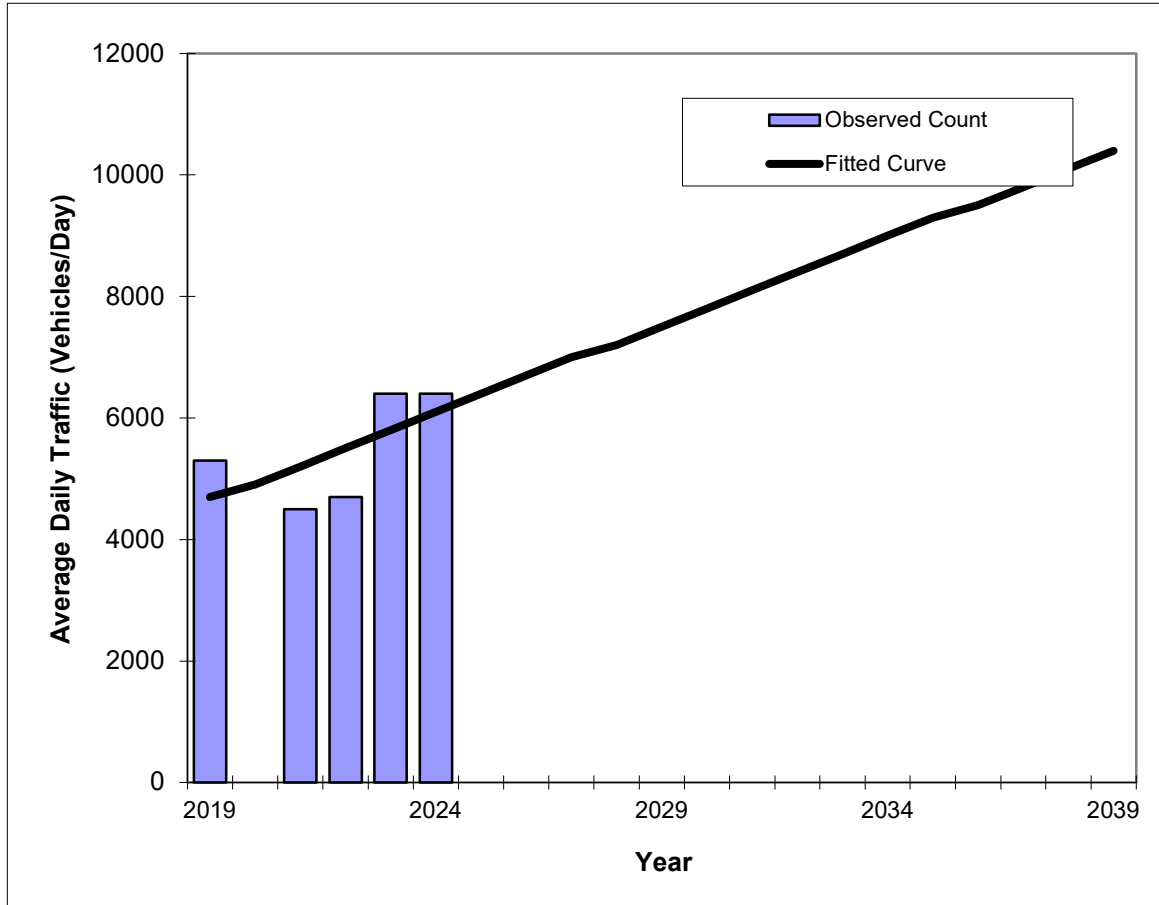

Year	Traffic (ADT/AADT)	
	Count*	Trend**
2019	5300	4700
2020	N/A	N/A
2021	4500	5200
2022	4700	5500
2023	6400	5800
2024	6400	6100
2025 Opening Year Trend		
2025	N/A	6400
2026 Mid-Year Trend		
2026	N/A	6700
2028 Design Year Trend		
2028	N/A	7200
TRANPLAN Forecasts/Trends		

** Annual Trend Increase:	288
Trend R-squared:	37.25%
Trend Annual Historic Growth Rate:	5.96%
Trend Growth Rate (2024 to Design Year):	4.51%
Printed:	18-Jun-25
Straight Line Growth Option	

*Axle-Adjusted

Traffic Trends - V03.a

16 ST -- 200' EAST OF MERIDIAN AVE (2011 OFF SYSTEM CYCLE)

FIN#	1234
Location	2

County:	Miami-Dade (87)
Station #:	8567
Highway:	16 ST

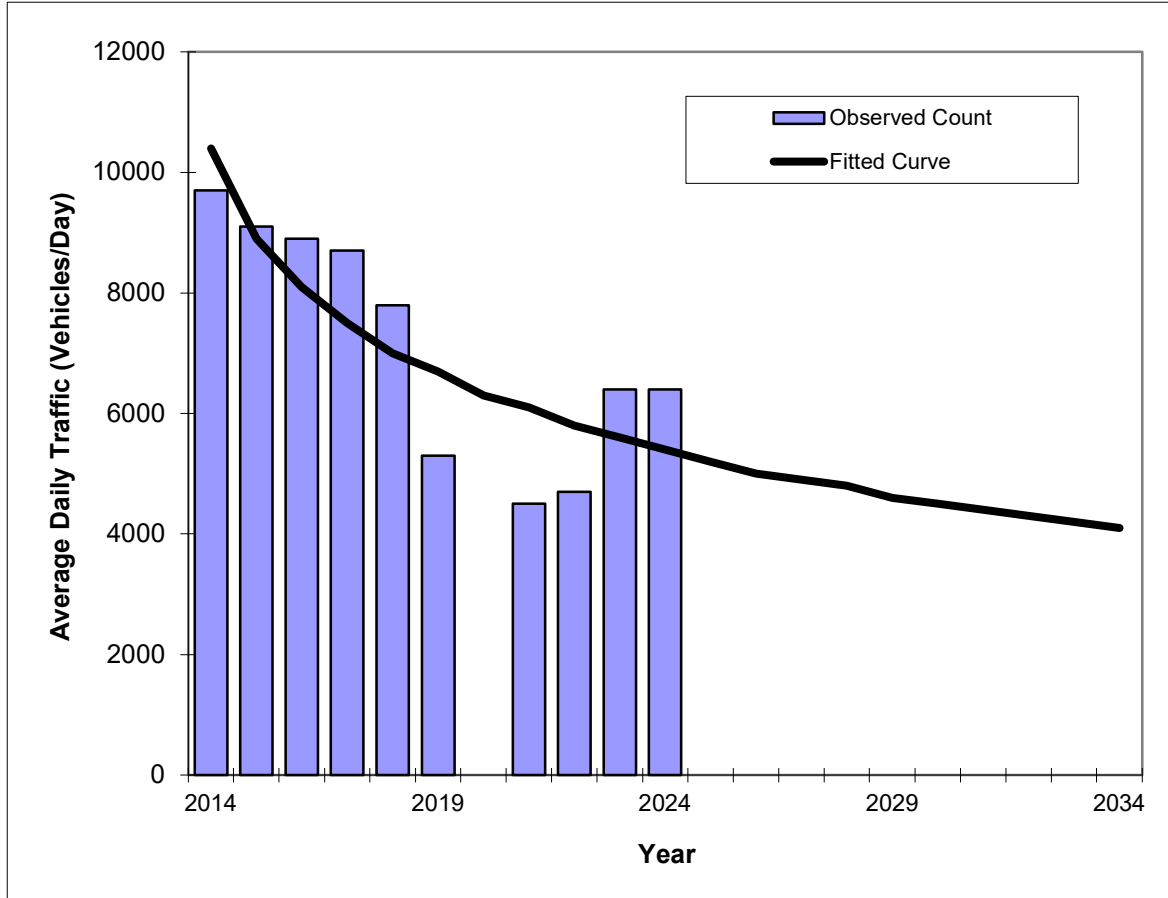

Year	Traffic (ADT/AADT)	
	Count*	Trend**
2014	9700	10400
2015	9100	8900
2016	8900	8100
2017	8700	7500
2018	7800	7000
2019	5300	6700
2020	N/A	N/A
2021	4500	6100
2022	4700	5800
2023	6400	5600
2024	6400	5400
2025 Opening Year Trend		
2025	N/A	5200
2026 Mid-Year Trend		
2026	N/A	5000
2028 Design Year Trend		
2028	N/A	4800
TRANPLAN Forecasts/Trends		

	Trend R-squared: 69.42%
	Compounded Annual Historic Growth Rate: -6.34%
	Compounded Growth Rate (2024 to Design Year): -2.90%
	Printed: 18-Jun-25
Decaying Exponential Growth Option	

*Axle-Adjusted

Traffic Trends - V03.a

16 ST -- 200' EAST OF MERIDIAN AVE (2011 OFF SYSTEM CYCLE)

FIN#	1234
Location	2

County:	Miami-Dade (87)
Station #:	8567
Highway:	16 ST

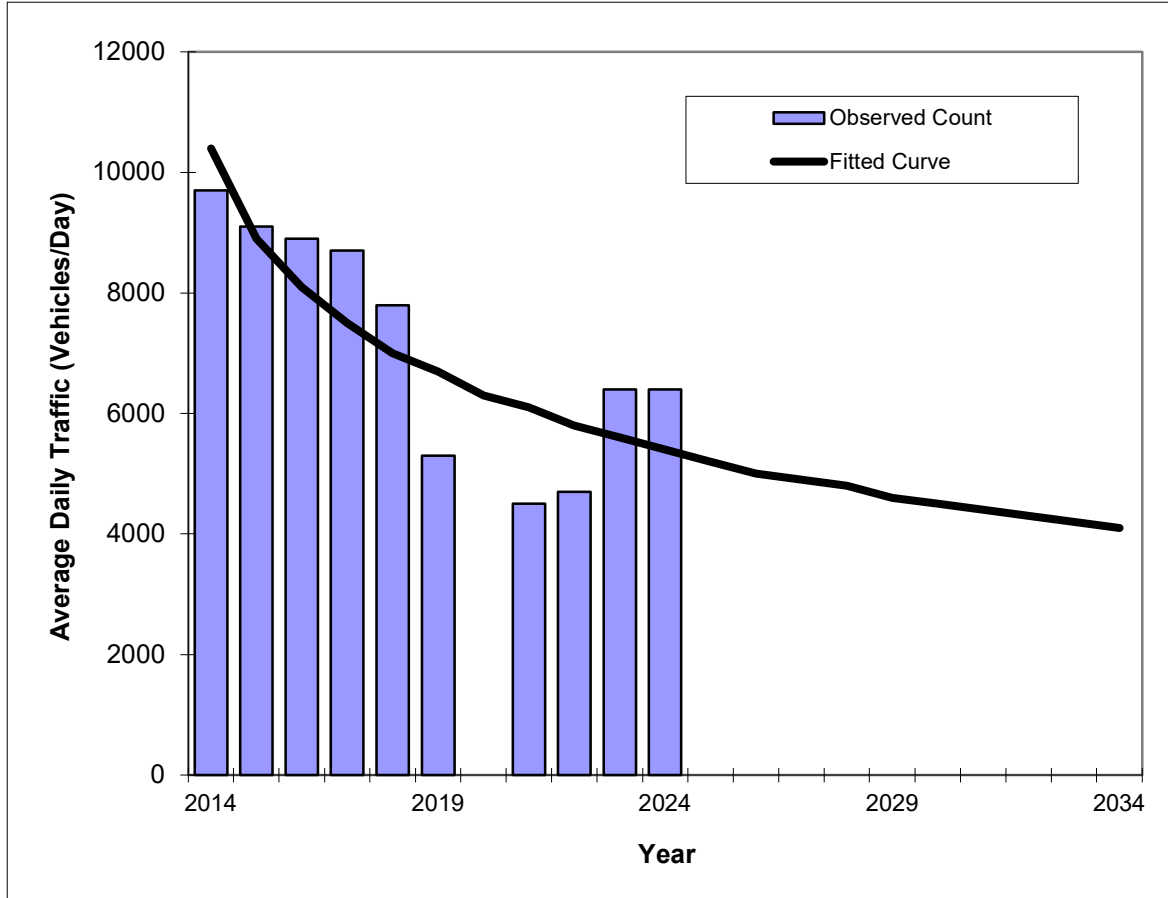

Year	Traffic (ADT/AADT)	
	Count*	Trend**
2014	9700	10400
2015	9100	8900
2016	8900	8100
2017	8700	7500
2018	7800	7000
2019	5300	6700
2020	N/A	N/A
2021	4500	6100
2022	4700	5800
2023	6400	5600
2024	6400	5400
2025 Opening Year Trend		
2025	N/A	5200
2026 Mid-Year Trend		
2026	N/A	5000
2028 Design Year Trend		
2028	N/A	4800
TRANPLAN Forecasts/Trends		

Trend R-squared:	58.34%
Compounded Annual Historic Growth Rate:	-6.34%
Compounded Growth Rate (2024 to Design Year):	-2.90%
Printed:	18-Jun-25
Exponential Growth Option	

*Axle-Adjusted

Traffic Trends - V03.a

16 ST -- 200' EAST OF MERIDIAN AVE (2011 OFF SYSTEM CYCLE)

FIN#	1234
Location	2

County:	Miami-Dade (87)
Station #:	8567
Highway:	16 ST

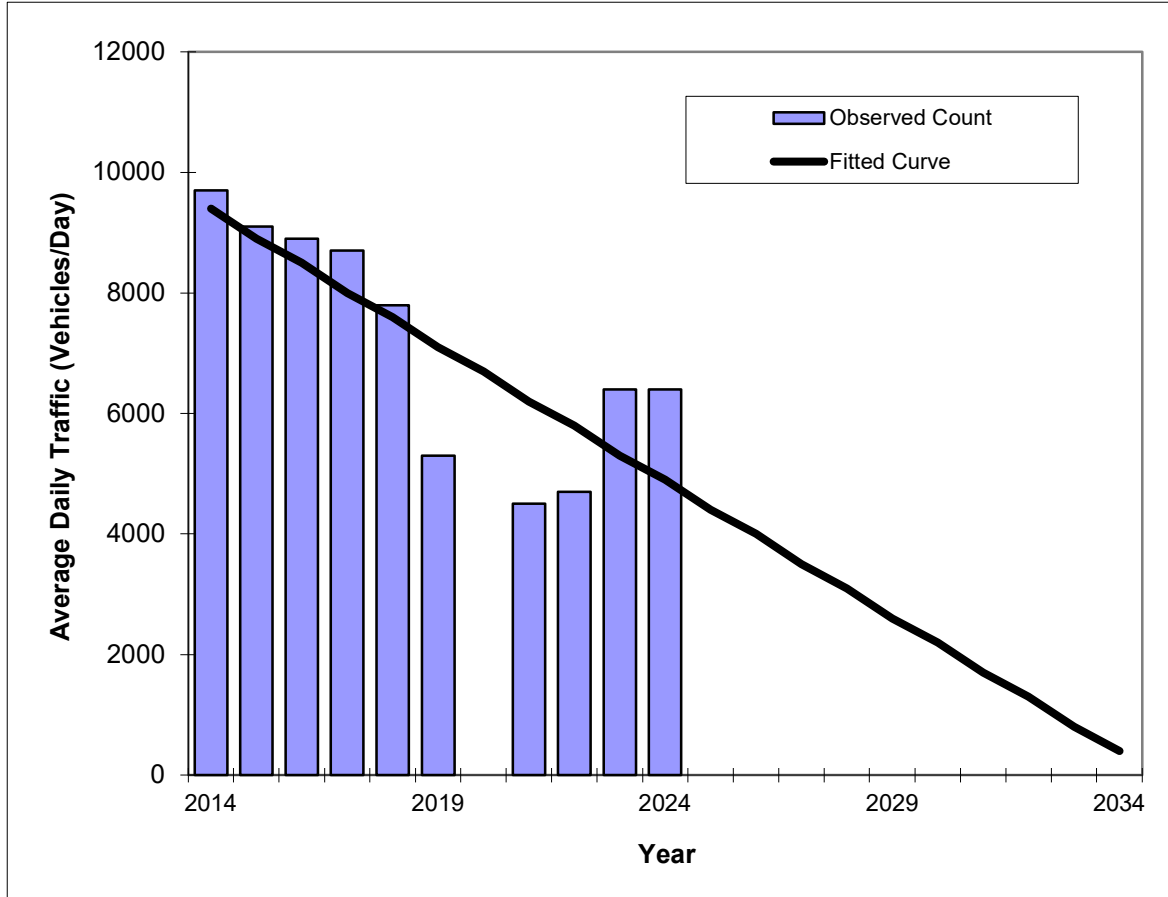

Year	Traffic (ADT/AADT)	
	Count*	Trend**
2014	9700	9400
2015	9100	8900
2016	8900	8500
2017	8700	8000
2018	7800	7600
2019	5300	7100
2020	N/A	N/A
2021	4500	6200
2022	4700	5800
2023	6400	5300
2024	6400	4900
2025 Opening Year Trend		
2025	N/A	4400
2026 Mid-Year Trend		
2026	N/A	4000
2028 Design Year Trend		
2028	N/A	3100
TRANPLAN Forecasts/Trends		

** Annual Trend Increase:	-449
Trend R-squared:	65.16%
Trend Annual Historic Growth Rate:	-4.79%
Trend Growth Rate (2024 to Design Year):	-9.18%
Printed:	18-Jun-25

Straight Line Growth Option

*Axle-Adjusted

Growth Rate Trend Analysis Calculations - 5 Years						
Description	FDOT Historical AADT Data			FDOT Historical AADT Data		
	8414			0		
Option	Linear	Exponential	Decaying Exponential	Linear	Exponential	Decaying Exponential
Trend Growth Rate 5 years	-7.18	-9.17	-9.17	5.96	3.86	3.86
Trend R-squared 5 years	60.98	59.31	81.46	37.25	34.19	18.01
Average Growth Rate (5-year) Linear all stations	-0.61					
Average Growth Rate (5-year) Exponential all stations	-2.66					
Average Growth Rate (5-year) Decaying Exponential all stations	-2.66					
Highest R-Square	81.46					
Growth Rate (5-year) with the highest R- Square	-2.66					
Growth Rate Trend Analysis Calculations - 10 Years						
Description	FDOT Historical AADT Data			FDOT Historical AADT Data		
	8414			0		
Option	Linear	Exponential	Decaying Exponential	Linear	Exponential	Decaying Exponential
Trend Growth Rate 10 years	-3.42	-3.50	-3.50	-4.79	-6.34	-6.34
Trend R-squared 10 years	64.99	67.22	46.93	65.16	58.34	69.42
Average Growth Rate (10-year) Linear all stations	-4.11					
Average Growth Rate (10-year) Exponential all stations	-4.92					
Average Growth Rate (10-year) Decaying Exponential all stations	-4.92					
Highest R-Square	69.42					
Growth Rate (10-year) with highest R- Square	-4.92					
Growth Rate Used	1.00					

Notes:

What Is R-squared?

R-squared is a statistical measure of how close the data are to the fitted regression line. It is also known as the coefficient of determination, or the coefficient of multiple determination for multiple regression.

The definition of R-squared is fairly straight-forward; it is the percentage of the response variable variation that is explained by a linear model. Or:

R-squared = Explained variation / Total variation

R-squared is always between 0 and 100%:

0% indicates that the model explains none of the variability of the response data around its mean.

100% indicates that the model explains all the variability of the response data around its mean.

In general, the higher the R-squared, the better the model fits your data. However, there are important conditions for this guideline that I'll talk about both in this post and my next post.

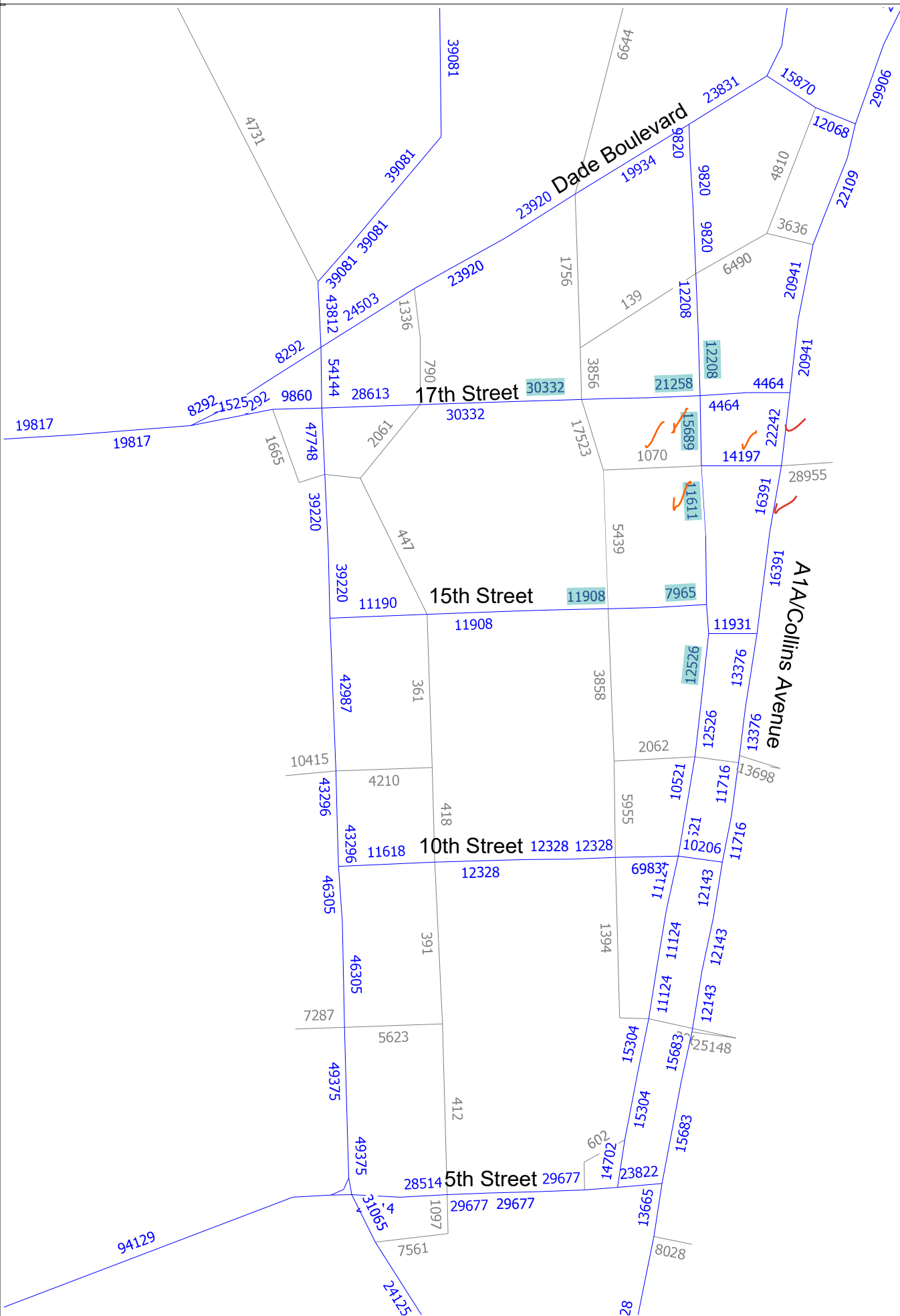



Table			
Future Growth Rate Analysis Based on Model Runs			
Location	Model		Growth Rate
	2015 Volume	2045 Volume	
Washington Avenue North of 16 Street	17,530	15,689	-0.37%
Washington Avenue North of 16 Street	11,520	11,611	0.03%
Collins Avenue North of 16 Street	15,676	22,242	1.17%
Collins Avenue North of 16 Street	16,171	16,391	0.05%
16 Street East of Washington	13,128	14,197	0.26%
16 Street West of Washington	1,420	1,070	-0.94%
Average Rate			0.03%



NOT TO SCALE

Legend

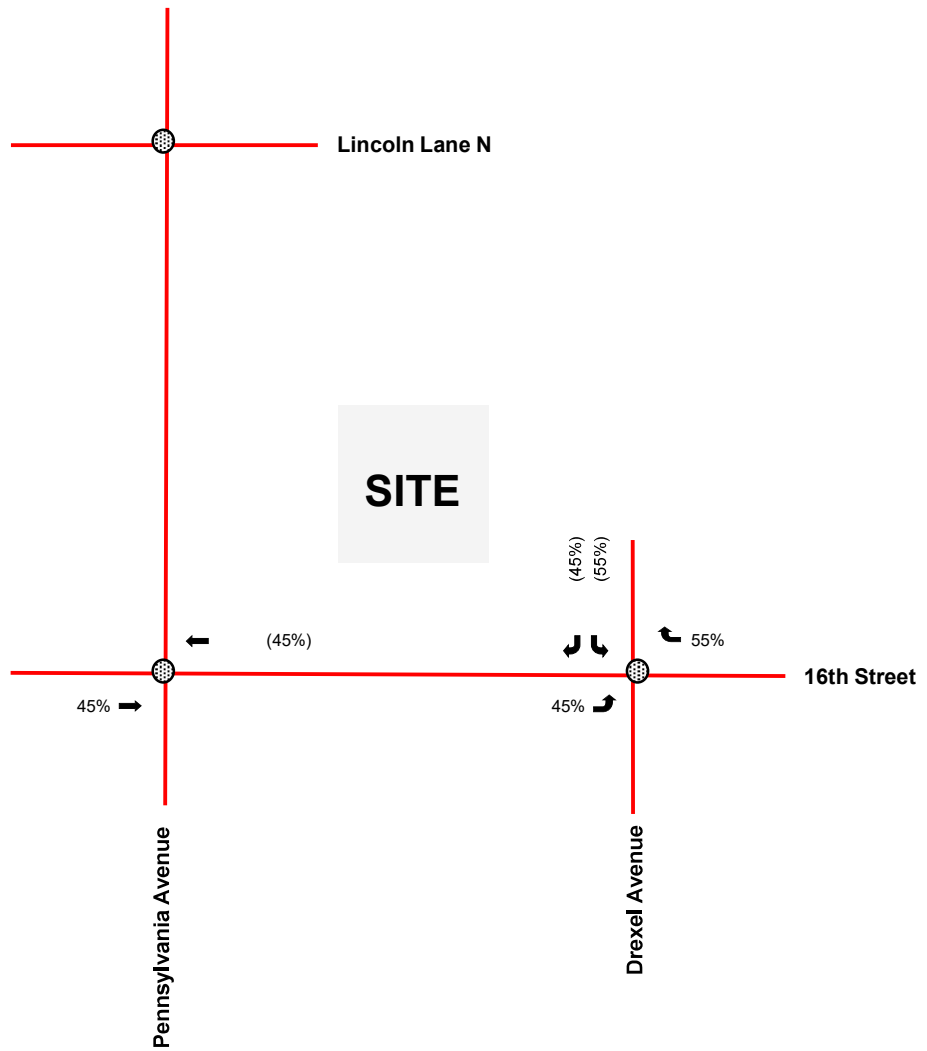

-  Study Roadway
-  Study Intersection
- XX% Entering Trip Distribution
- (XX%) Exiting Trip Distribution





NOT TO SCALE

Legend

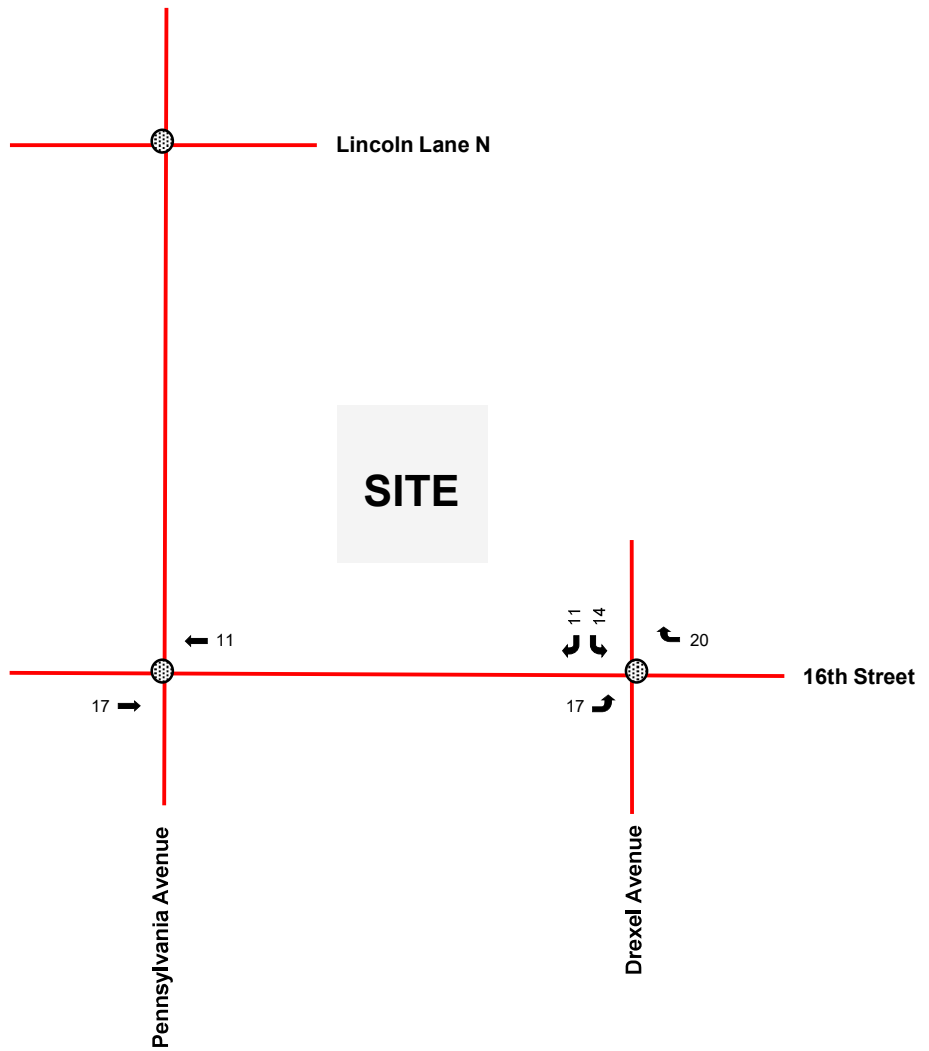

-  Study Roadway
-  Study Intersection
-  Saturday P.M. Valet Peak Hour Trip Assignment





NOT TO SCALE

Legend

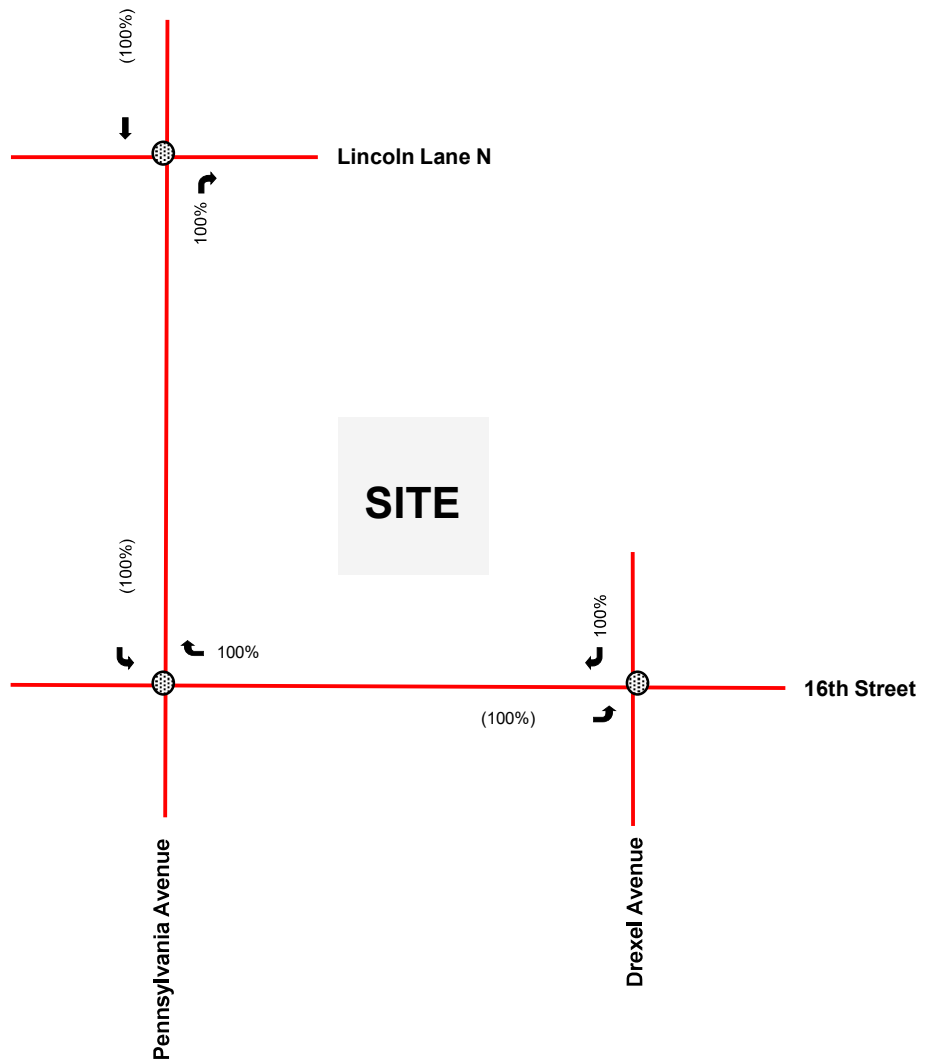

-  Study Roadway
-  Study Intersection
- XX% Entering Trip Distribution
- (XX%) Exiting Trip Distribution





NOT TO SCALE

Legend

-  Study Roadway
-  Study Intersection
-  Saturday P.M. Valet Peak Hour Trip Assignment

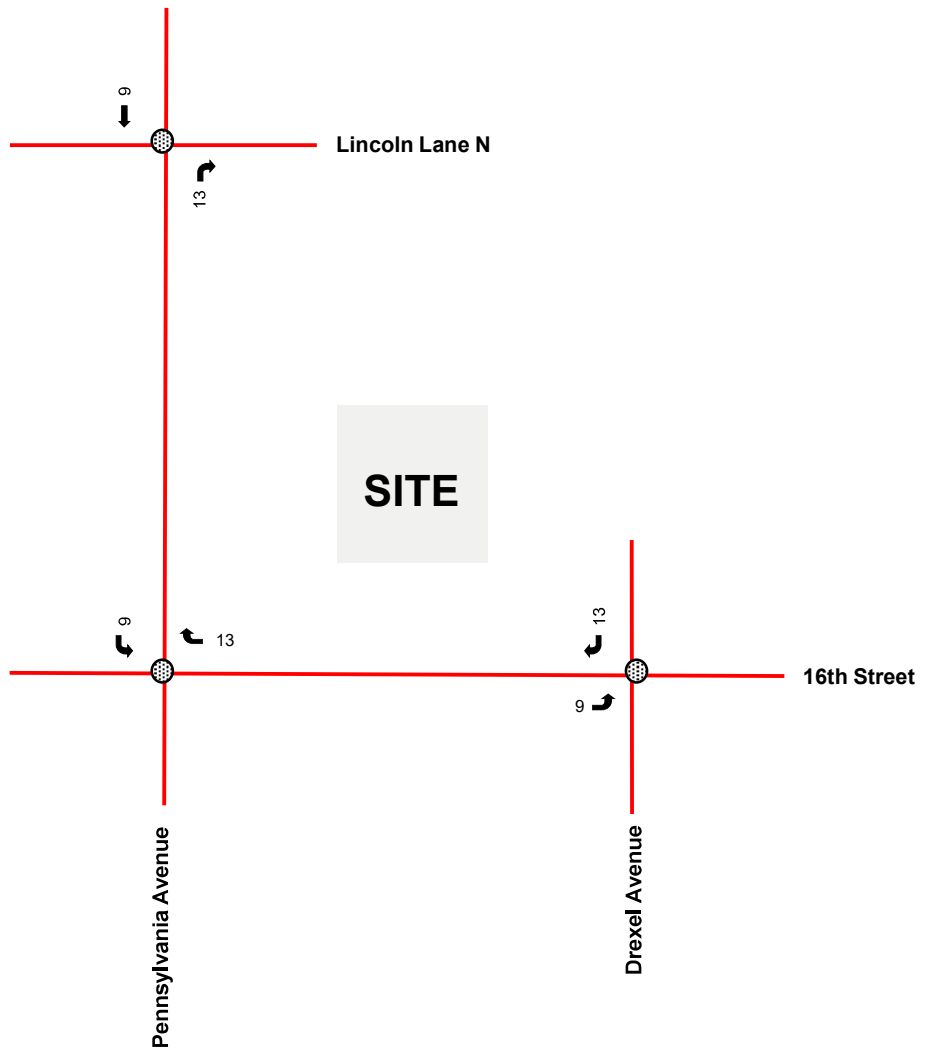

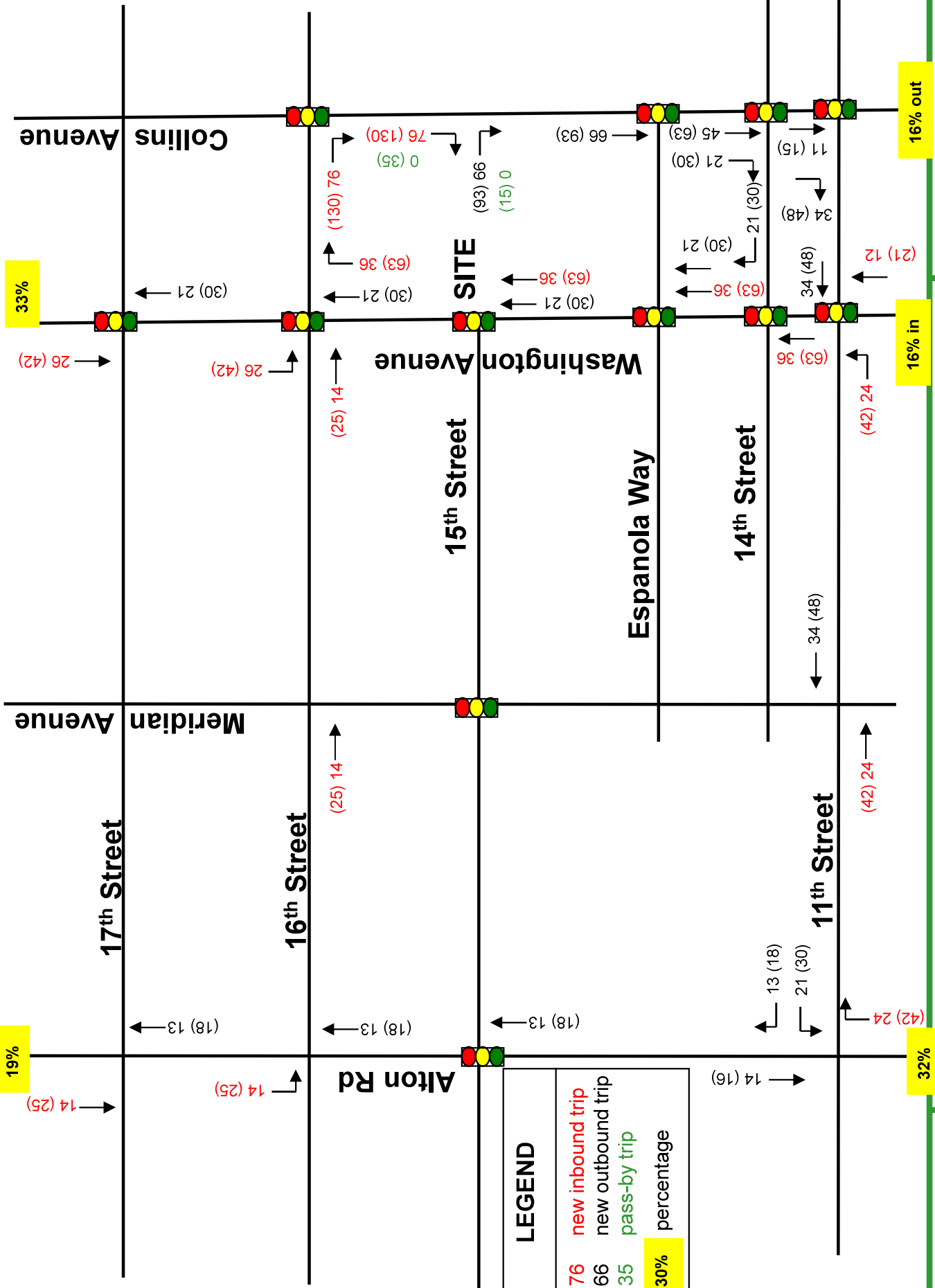

NEW PROJECT TRAFFIC ASSIGNMENT
Weekday New Peak Hour Trips AM & (PM)

FIGURE 4a
 Icon Hotel
 Miami Beach, Florida



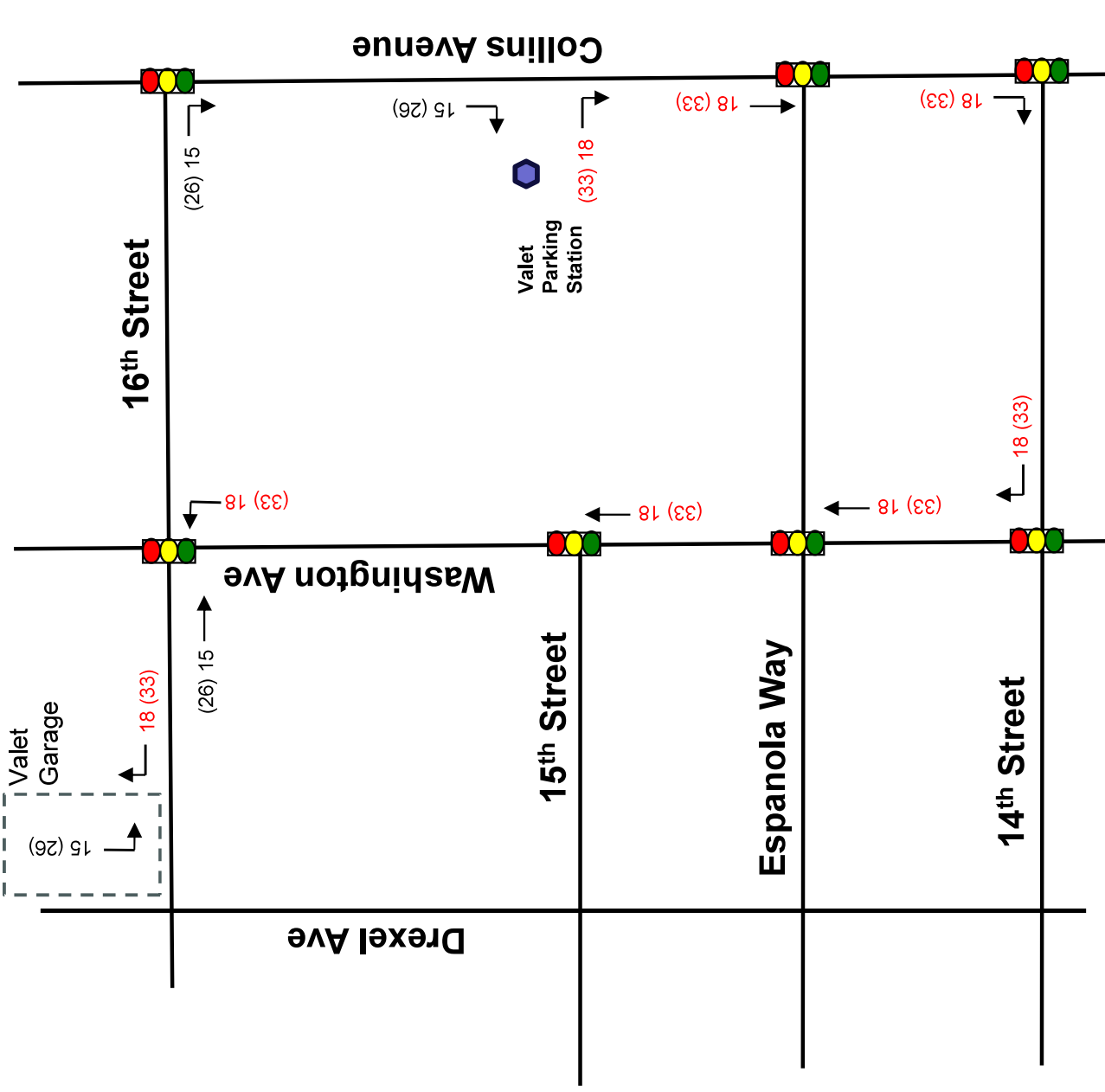

LEGEND	
14	Inbound Valet Trip
20	Outbound Valet Trip

Assumed that 20% of the project trips will use valet parking (18 ins / 15 out AM Peak & 33 ins / 26 out PM Peak)

**VALET PARKING
Weekday New Peak Hour Trips AM & (PM)**





FIGURE 4b
Icon Hotel
Miami Beach, Florida





NOT TO SCALE

Legend

-  Study Roadway
-  Study Intersection
-  XX% Entering Trip Distribution
-  (XX%) Exiting Trip Distribution

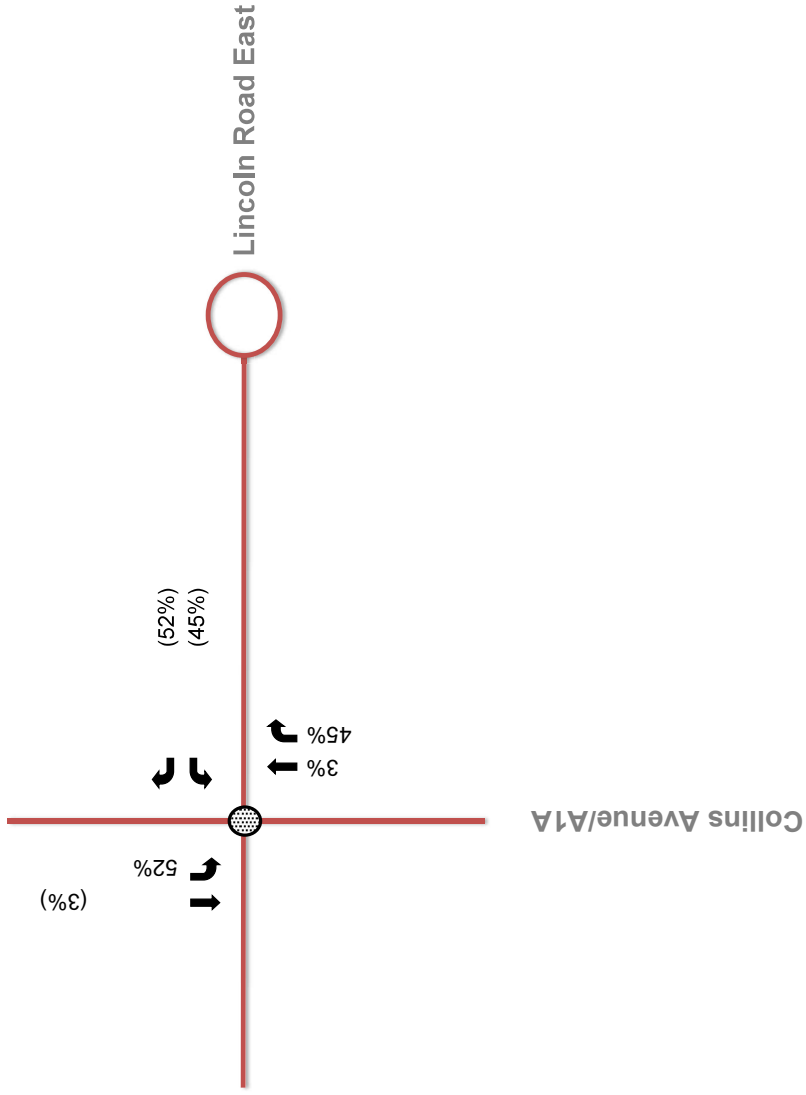

Figure 4
Peak Hour Project Trip Distribution
Lincoln Road East
Miami Beach, Florida



NOT TO SCALE

Legend



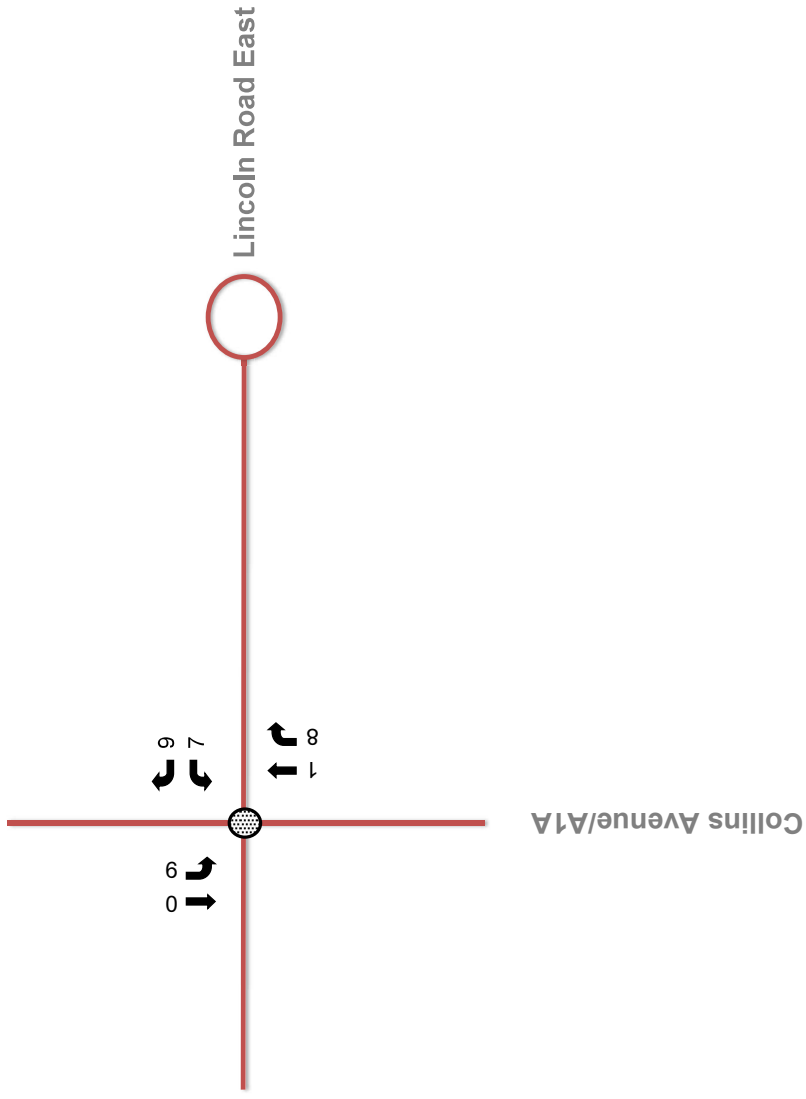

-  Study Roadway
-  Study Intersection
- XX** Mid-Day/P.M. Peak Hour Trip Assignment





NOT TO SCALE

Legend

-  Study Roadway
-  Study Intersection
-  XX% Valet Drop-Off Trip Distribution
-  (XX%) Valet Pick-Up Trip Distribution

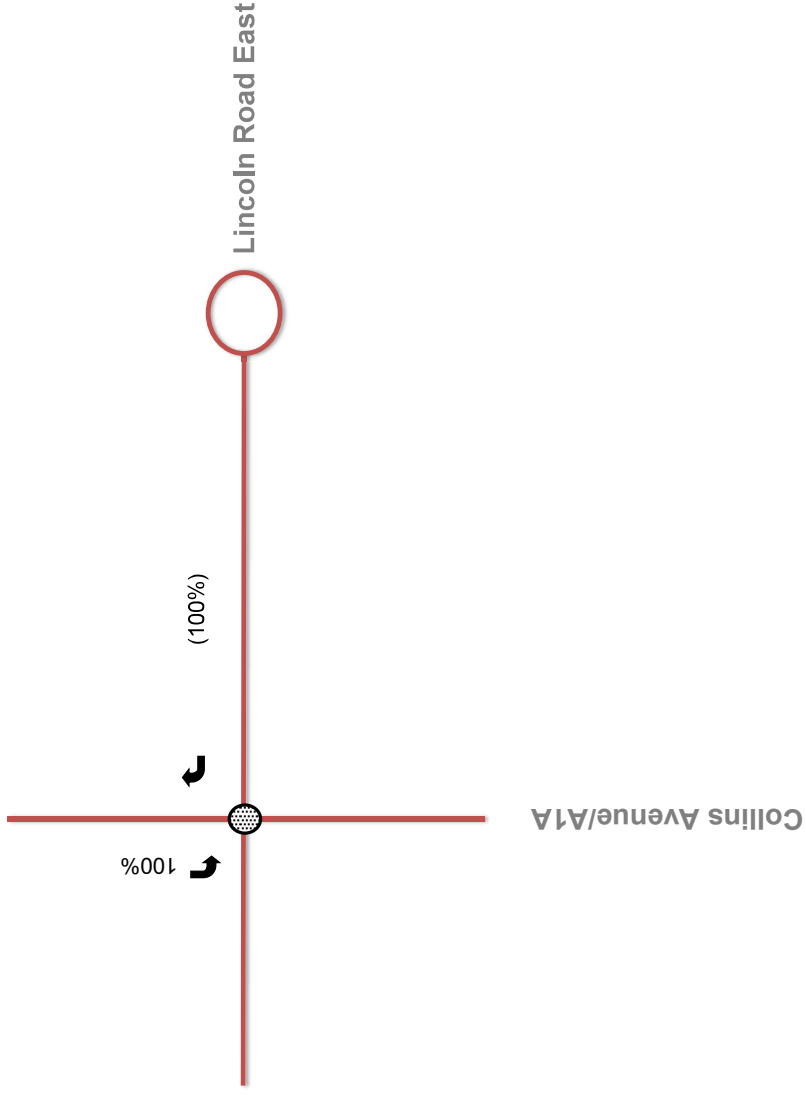

Figure 6
Peak Hour Valet Trip Distribution
Lincoln Road East
Miami Beach, Florida



NOT TO SCALE

Legend

-  Study Roadway
-  Study Intersection
-  Mid-Day/P.M. Peak Hour Valet Trip Assignment

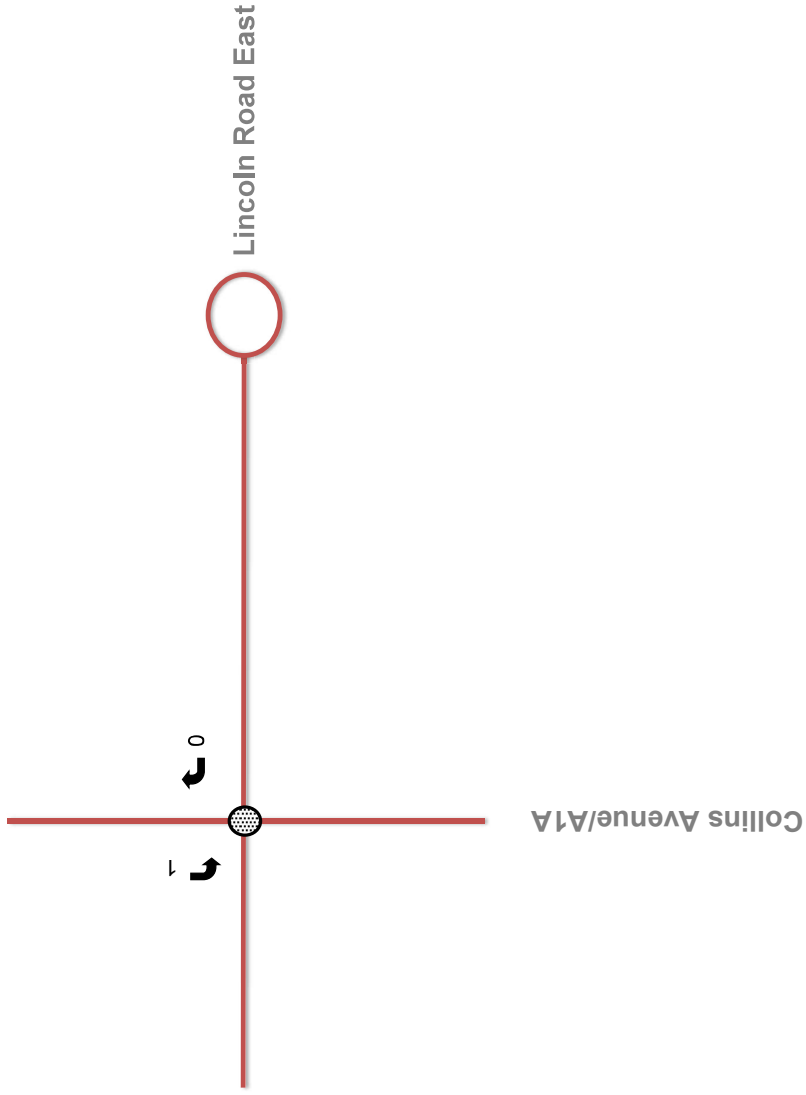



NOT TO SCALE

Legend

- Study Roadway
- Study Intersection
- P.M. Peak Hour Traffic

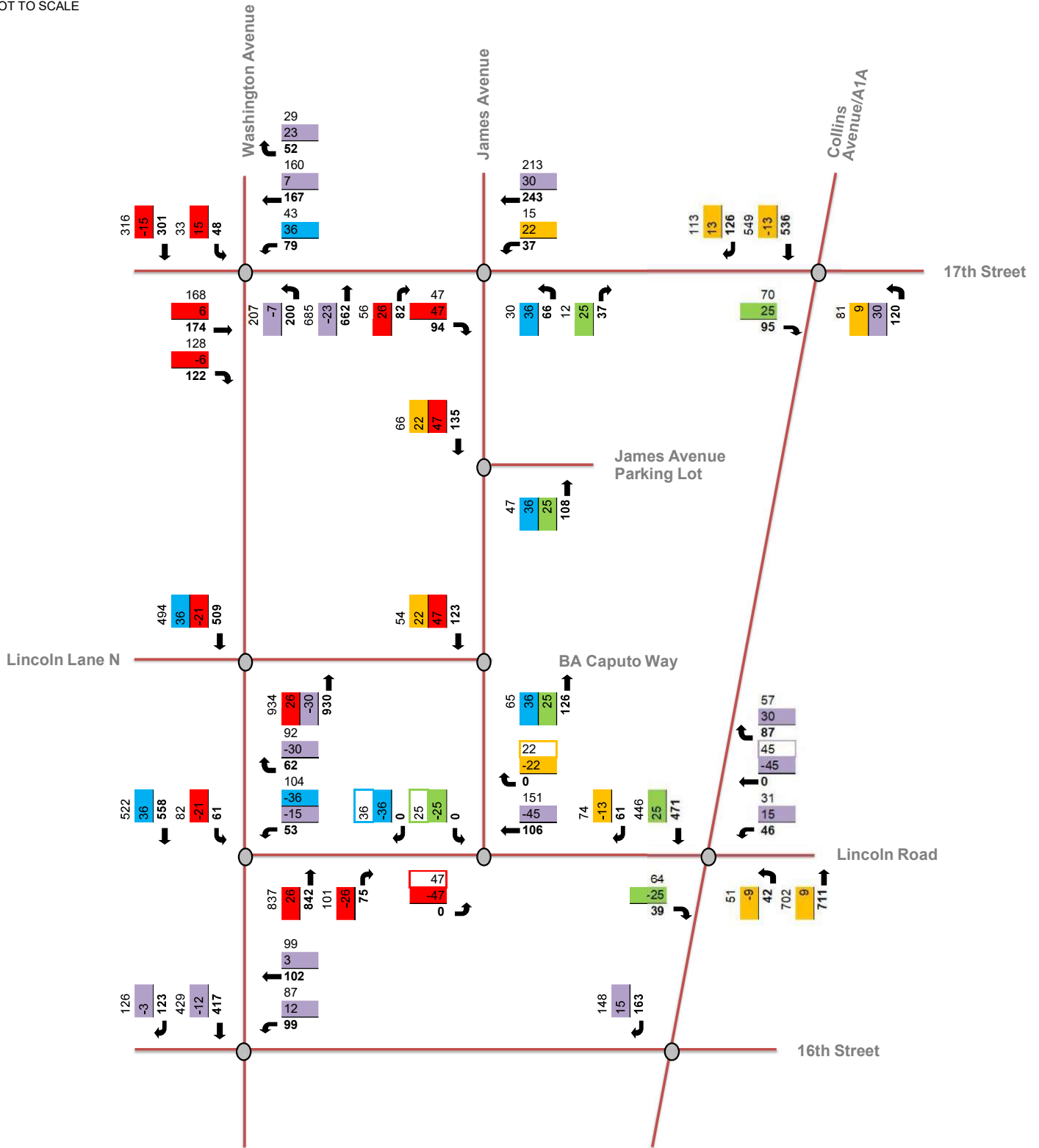

Figure 4
James Avenue Traffic Diversions
Lincoln Road Pedestrian Mall Extension
Miami, Florida



NOT TO SCALE

Legend

- Study Roadway
- Study Intersection
- P.M. Peak Hour Traffic

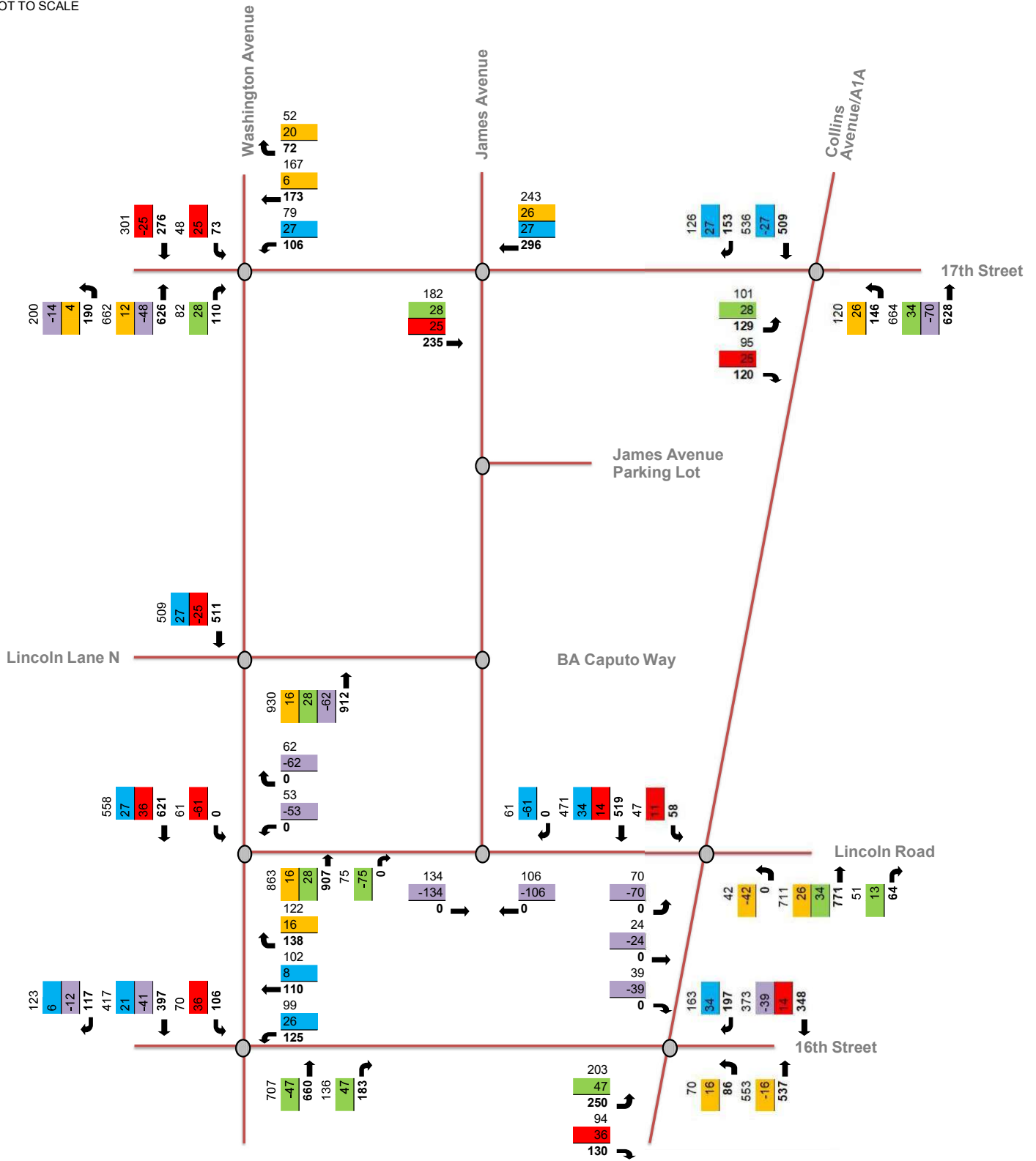

Figure 5
Lincoln Road Traffic Diversions
Lincoln Road Pedestrian Mall Extension
Miami, Florida

APPENDIX E

Future Turning Movement Volumes

FUTURE TURNING MOVEMENT VOLUME ANALYSIS

Drexel Avenue and 16 Street AM Peak Hour

Description	Drexel Avenue Northbound			Drexel Avenue Southbound			16 Street Eastbound			16 Street Westbound		
	Left	Through	Right	Left	Through	Right	Left	Through	Right	Left	Through	Right
Existing Traffic (6/12/2025)	10	2	10	2	2	2	9	151	4	5	96	9
Season Adjustment Factor	1.12	1.12	1.12	1.12	1.12	1.12	1.12	1.12	1.12	1.12	1.12	1.12
2025 Peak Season Traffic	11	2	11	2	2	2	10	169	4	6	108	10
Annual Growth Rate	1.0%	1.0%	1.0%	1.0%	1.0%	1.0%	1.0%	1.0%	1.0%	1.0%	1.0%	1.0%
Committed Developments 1620 Drexel 1501 Washington Lincoln Road 200-300 Block JAD Lincoln Road 200-300 Block LRD Lincoln Road 100 Block								14				
2028 Background Traffic	12	2	12	2	2	2	10	188	5	6	111	10
1600 Washington			1					8		1	16	1
2028 Total Traffic	12	2	13	2	2	2	10	196	5	7	127	11

FUTURE TURNING MOVEMENT VOLUME ANALYSIS

**Drexel Avenue and 16 Street
AM Peak Hour**

Description	Drexel Avenue Northbound			Drexel Avenue Southbound			16 Street Eastbound			16 Street Westbound		
	Left	Through	Right	Left	Through	Right	Left	Through	Right	Left	Through	Right
Existing Traffic (6/12/2025)	18	6	7	7	2	15	27	137	21	17	227	43
Season Adjustment Factor	1.12	1.12	1.12	1.12	1.12	1.12	1.12	1.12	1.12	1.12	1.12	1.12
2025 Peak Season Traffic	20	7	8	8	2	17	30	153	24	19	254	48
Annual Growth Rate	1.0%	1.0%	1.0%	1.0%	1.0%	1.0%	1.0%	1.0%	1.0%	1.0%	1.0%	1.0%
Committed Developments 1620 Drexel 1501 Washington Lincoln Road 200-300 Block JAD Lincoln Road 200-300 Block LRD Lincoln Road 100 Block				14		24	26	25				20
2028 Background Traffic	21	7	8	22	2	41	57	183	24	20	262	70
1600 Washington			1					11		1	8	
2028 Total Traffic	21	7	9	22	2	41	57	194	24	21	270	70

FUTURE TURNING MOVEMENT VOLUME ANALYSIS

**16 Street and Garage Entrance
AM Peak Hour**

Description	Garage Entrance Northbound			Garage Entrance Southbound			16 Street Eastbound			16 Street Westbound		
	Left	Through	Right	Left	Through	Right	Left	Through	Right	Left	Through	Right
Existing Traffic (6/12/2025)				3		7	47	113			99	32
Season Adjustment Factor	1.12	1.12	1.12	1.12	1.12	1.12	1.12	1.12	1.12	1.12	1.12	1.12
2025 Peak Season Traffic	0	0	0	3	0	8	53	127	0	0	111	36
Annual Growth Rate	1.0%	1.0%	1.0%	1.0%	1.0%	1.0%	1.0%	1.0%	1.0%	1.0%	1.0%	1.0%
Committed Developments 1620 Drexel 1501 Washington Lincoln Road 200-300 Block JAD Lincoln Road 200-300 Block LRD Lincoln Road 100 Block								14				
2028 Background Traffic	0	0	0	3	0	8	54	144	0	0	114	37
1600 Washington				23		18	8					11
2028 Total Traffic	0	0	0	26	0	26	62	144	0	0	114	48

FUTURE TURNING MOVEMENT VOLUME ANALYSIS

**16 Street and Garage Entrance
AM Peak Hour**

Description	Garage Entrance Northbound			Garage Entrance Southbound			16 Street Eastbound			16 Street Westbound		
	Left	Through	Right	Left	Through	Right	Left	Through	Right	Left	Through	Right
Existing Traffic (6/12/2025)				18		35	12	141			250	14
Season Adjustment Factor	1.12	1.12	1.12	1.12	1.12	1.12	1.12	1.12	1.12	1.12	1.12	1.12
2025 Peak Season Traffic	0	0	0	20	0	39	13	158	0	0	280	16
Annual Growth Rate	1.0%	1.0%	1.0%	1.0%	1.0%	1.0%	1.0%	1.0%	1.0%	1.0%	1.0%	1.0%
Committed Developments												
1620 Drexel								14			20	
1501 Washington								25				
Lincoln Road 200-300 Block JAD												
Lincoln Road 200-300 Block LRD												
Lincoln Road 100 Block												
2028 Background Traffic	0	0	0	21	0	40	14	202	0	0	308	16
1600 Washington				8		7	11					8
2028 Total Traffic	0	0	0	29	0	47	25	202	0	0	308	24

FUTURE TURNING MOVEMENT VOLUME ANALYSIS

**Washington Avenue and 16 Street
AM Peak Hour**

Description	Washington Avenue Northbound			Washington Avenue Southbound			16 Street Eastbound			16 Street Westbound		
	Left	Through	Right	Left	Through	Right	Left	Through	Right	Left	Through	Right
Existing Traffic (6/12/2025)	29	176	31	50	285	68	27	63	23	23	45	36
Season Adjustment Factor	1.12	1.12	1.12	1.12	1.12	1.12	1.12	1.12	1.12	1.12	1.12	1.12
2025 Peak Season Traffic	32	197	35	56	319	76	30	71	26	26	50	40
Annual Growth Rate	1.0%	1.0%	1.0%	1.0%	1.0%	1.0%	1.0%	1.0%	1.0%	1.0%	1.0%	1.0%
Committed Developments 1620 Drexel 1501 Washington Lincoln Road 200-300 Block JAD Lincoln Road 200-300 Block LRD Lincoln Road 100 Block		21	36	26				14				
2028 Background Traffic	33	224	72	84	329	78	31	87	27	27	52	42
1600 Washington	1					3	7	14	2		6	
2028 Total Traffic	34	224	72	84	329	81	38	101	29	27	58	42

FUTURE TURNING MOVEMENT VOLUME ANALYSIS

**Washington Avenue and 16 Street
PM Peak Hour**

Description	Washington Avenue Northbound			Washington Avenue Southbound			16 Street Eastbound			16 Street Westbound		
	Left	Through	Right	Left	Through	Right	Left	Through	Right	Left	Through	Right
Existing Traffic (6/12/2025)	43	520	47	60	527	133	35	81	41	47	99	102
Season Adjustment Factor	1.12	1.12	1.12	1.12	1.12	1.12	1.12	1.12	1.12	1.12	1.12	1.12
2025 Peak Season Traffic	48	582	53	67	590	149	39	91	46	53	111	114
Annual Growth Rate	1.0%	1.0%	1.0%	1.0%	1.0%	1.0%	1.0%	1.0%	1.0%	1.0%	1.0%	1.0%
Committed Developments												
1620 Drexel								14			20	
1501 Washington		30	63	42				25				
Lincoln Road 200-300 Block JAD				-3	-12					12	3	
Lincoln Road 200-300 Block LRD		-47	47	36	-20	-6				36	8	16
Lincoln Road 100 Block												
2028 Background Traffic	50	583	164	144	576	147	40	132	47	102	145	134
1600 Washington	1					5	3	6	1		9	
2028 Total Traffic	51	583	164	144	576	152	43	138	48	102	154	134

FUTURE TURNING MOVEMENT VOLUME ANALYSIS

**Collins Avenue and 16th Street
AM Peak Hour**

Description	Collins Avenue Northbound			Collins Avenue Southbound			16th Street Eastbound			16th Street Westbound		
	Left	Through	Right	Left	Through	Right	Left	Through	Right	Left	Through	Right
Existing Traffic (6/12/2025)	23	269	5	11	342	96	45	3	45	2	5	8
Season Adjustment Factor	1.12	1.12	1.12	1.12	1.12	1.12	1.12	1.12	1.12	1.12	1.12	1.12
2025 Peak Season Traffic	26	301	6	12	383	108	50	3	50	2	6	9
Annual Growth Rate	1.0%	1.0%	1.0%	1.0%	1.0%	1.0%	1.0%	1.0%	1.0%	1.0%	1.0%	1.0%
Committed Developments 1620 Drexel 1501 Washington Lincoln Road 200-300 Block JAD Lincoln Road 200-300 Block LRD Lincoln Road 100 Block									76			
2028 Background Traffic	27	310	6	13	395	111	52	3	128	2	6	9
1600 Washington	2					4	10		4			
2028 Total Traffic	29	310	6	13	395	115	62	3	132	2	6	9

FUTURE TURNING MOVEMENT VOLUME ANALYSIS

**Collins Avenue and 16th Street
PM Peak Hour**

Description	Collins Avenue Northbound			Collins Avenue Southbound			16th Street Eastbound			16th Street Westbound		
	Left	Through	Right	Left	Through	Right	Left	Through	Right	Left	Through	Right
Existing Traffic (6/12/2025)	57	389	9	16	448	115	113	8	60	6	5	11
Season Adjustment Factor	1.12	1.12	1.12	1.12	1.12	1.12	1.12	1.12	1.12	1.12	1.12	1.12
2025 Peak Season Traffic	64	436	10	18	502	129	127	9	67	7	6	12
Annual Growth Rate	1.0%	1.0%	1.0%	1.0%	1.0%	1.0%	1.0%	1.0%	1.0%	1.0%	1.0%	1.0%
Committed Developments												
1620 Drexel												
1501 Washington									130			
Lincoln Road 200-300 Block JAD						15						
Lincoln Road 200-300 Block LRD	16	-16			-25	34	14		36			
Lincoln Road 100 Block		9			7							
2028 Background Traffic	82	442	10	18	499	182	144	9	235	7	6	13
1600 Washington	3					6	4		2			
2028 Total Traffic	85	442	10	18	499	188	148	9	237	7	6	13

APPENDIX F
SYNCHRO Analyses

Timings
101: Drexel Avenue & 16 Street

07/11/2025

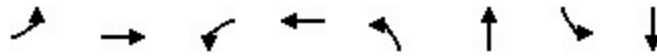

Lane Group	EBL	EBT	WBL	WBT	NBL	NBT	SBL	SBT	Ø7
Lane Configurations		↕		↕		↕		↕	
Traffic Volume (vph)	10	188	6	111	12	2	2	2	
Future Volume (vph)	10	188	6	111	12	2	2	2	
Turn Type	Perm	NA	Perm	NA	Perm	NA	Perm	NA	
Protected Phases		6		2		4		8	7
Permitted Phases	6		2		4		8		
Detector Phase	6	6	2	2	4	4	8	8	
Switch Phase									
Minimum Initial (s)	16.0	16.0	16.0	16.0	7.0	7.0	7.0	7.0	1.0
Minimum Split (s)	46.0	46.0	46.0	46.0	32.0	32.0	32.0	32.0	67.0
Total Split (s)	46.0	46.0	46.0	46.0	28.0	28.0	28.0	28.0	56.0
Total Split (%)	35.4%	35.4%	35.4%	35.4%	21.5%	21.5%	21.5%	21.5%	43%
Maximum Green (s)	40.0	40.0	40.0	40.0	22.0	22.0	22.0	22.0	50.0
Yellow Time (s)	4.0	4.0	4.0	4.0	4.0	4.0	4.0	4.0	4.0
All-Red Time (s)	2.0	2.0	2.0	2.0	2.0	2.0	2.0	2.0	2.0
Lost Time Adjust (s)		0.0		0.0		0.0		0.0	
Total Lost Time (s)		6.0		6.0		6.0		6.0	
Lead/Lag									
Lead-Lag Optimize?									
Vehicle Extension (s)	1.0	1.0	1.0	1.0	2.5	2.5	2.5	2.5	0.2
Recall Mode	Max	Max	Max	Max	None	None	None	None	None
Walk Time (s)	5.0	5.0	5.0	5.0	5.0	5.0	5.0	5.0	5.0
Flash Don't Walk (s)	21.0	21.0	21.0	21.0	21.0	21.0	21.0	21.0	56.0
Pedestrian Calls (#/hr)	63	63	63	63	31	31	31	31	3

Intersection Summary

Cycle Length: 130
 Actuated Cycle Length: 90.6
 Natural Cycle: 145
 Control Type: Actuated-Uncoordinated

Splits and Phases: 101: Drexel Avenue & 16 Street

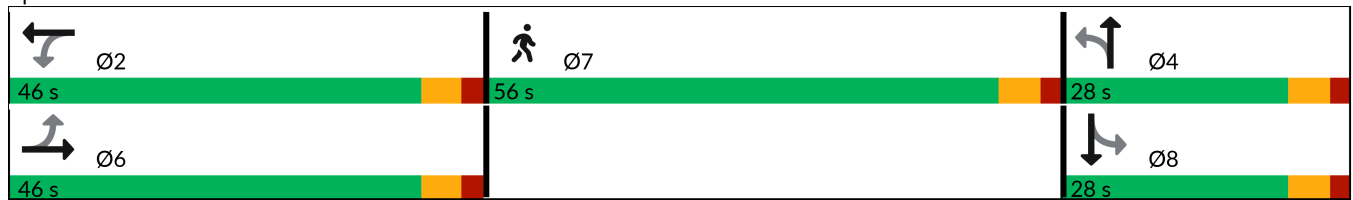

101: Drexel Avenue & 16 Street

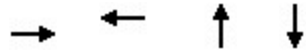

















Lane Group	EBT	WBT	NBT	SBT
Lane Group Flow (vph)	267	167	35	9
v/c Ratio	0.24	0.15	0.13	0.03
Control Delay (s/veh)	19.3	18.7	26.0	32.0
Queue Delay	0.0	0.0	0.0	0.0
Total Delay (s/veh)	19.3	18.7	26.0	32.0
Queue Length 50th (ft)	71	41	8	3
Queue Length 95th (ft)	257	161	38	18
Internal Link Dist (ft)	176	70	207	304
Turn Bay Length (ft)				
Base Capacity (vph)	1121	1110	388	414
Starvation Cap Reductn	0	0	0	0
Spillback Cap Reductn	0	0	0	0
Storage Cap Reductn	0	0	0	0
Reduced v/c Ratio	0.24	0.15	0.09	0.02

Intersection Summary

HCM Signalized Intersection Capacity Analysis
101: Drexel Avenue & 16 Street

07/11/2025

													
Movement	EBL	EBT	EBR	WBL	WBT	WBR	NBL	NBT	NBR	SBL	SBT	SBR	
Lane Configurations													
Traffic Volume (vph)	10	188	5	6	111	10	12	2	12	2	2	2	
Future Volume (vph)	10	188	5	6	111	10	12	2	12	2	2	2	
Ideal Flow (vphpl)	1900	1900	1900	1900	1900	1900	1900	1900	1900	1900	1900	1900	
Total Lost time (s)		6.0			6.0			6.0			6.0		
Lane Util. Factor		1.00			1.00			1.00			1.00		
Frbp, ped/bikes		1.00			0.99			0.97			0.98		
Flpb, ped/bikes		1.00			1.00			0.99			0.99		
Frt		1.00			0.99			0.94			0.96		
Flt Protected		1.00			1.00			0.98			0.98		
Satd. Flow (prot)		1643			1625			1463			1515		
Flt Permitted		0.99			0.99			0.87			0.92		
Satd. Flow (perm)		1624			1605			1305			1423		
Peak-hour factor, PHF	0.76	0.76	0.76	0.76	0.76	0.76	0.76	0.76	0.76	0.76	0.76	0.76	
Adj. Flow (vph)	13	247	7	8	146	13	16	3	16	3	3	3	
RTOR Reduction (vph)	0	0	0	0	1	0	0	14	0	0	3	0	
Lane Group Flow (vph)	0	267	0	0	166	0	0	21	0	0	6	0	
Confl. Peds. (#/hr)	31		39	39		31	16		19	19		16	
Confl. Bikes (#/hr)			2			3			1			1	
Parking (#/hr)	0	0	0	0	0	0	0	0	0	0	0	0	
Turn Type	Perm	NA		Perm	NA		Perm	NA		Perm	NA		
Protected Phases		6			2			4			8		
Permitted Phases	6			2			4			8			
Actuated Green, G (s)		59.1			59.1			13.4			13.4		
Effective Green, g (s)		59.1			59.1			13.4			13.4		
Actuated g/C Ratio		0.60			0.60			0.14			0.14		
Clearance Time (s)		6.0			6.0			6.0			6.0		
Vehicle Extension (s)		1.0			1.0			2.5			2.5		
Lane Grp Cap (vph)		978			966			178			194		
v/s Ratio Prot													
v/s Ratio Perm		c0.16			0.10			c0.02			0.00		
v/c Ratio		0.27			0.17			0.12			0.03		
Uniform Delay, d1		9.3			8.6			37.2			36.7		
Progression Factor		1.00			1.00			1.00			1.00		
Incremental Delay, d2		0.7			0.4			0.2			0.1		
Delay (s)		10.0			9.0			37.4			36.8		
Level of Service		A			A			D			D		
Approach Delay (s/veh)		10.0			9.0			37.4			36.8		
Approach LOS		A			A			D			D		
Intersection Summary													
HCM 2000 Control Delay (s/veh)			12.2									HCM 2000 Level of Service	B
HCM 2000 Volume to Capacity ratio			0.22										
Actuated Cycle Length (s)			98.1									Sum of lost time (s)	18.0
Intersection Capacity Utilization			44.9%									ICU Level of Service	A
Analysis Period (min)			15										
c Critical Lane Group													

HCM 7th Edition methodology does not support exclusive ped or hold phases.

Intersection						
Int Delay, s/veh	1.5					
Movement	EBL	EBT	WBT	WBR	SBL	SBR
Lane Configurations		↶	↷		↶	↷
Traffic Vol, veh/h	54	144	114	37	3	8
Future Vol, veh/h	54	144	114	37	3	8
Conflicting Peds, #/hr	40	0	0	40	1	0
Sign Control	Free	Free	Free	Free	Stop	Stop
RT Channelized	-	None	-	None	-	None
Storage Length	-	-	-	-	0	0
Veh in Median Storage, #	-	0	0	-	0	-
Grade, %	-	0	0	-	0	-
Peak Hour Factor	80	80	80	80	80	80
Heavy Vehicles, %	3	3	3	3	3	3
Mvmt Flow	68	180	143	46	4	10

Major/Minor	Major1	Major2	Minor2		
Conflicting Flow All	229	0	-	0	522 206
Stage 1	-	-	-	-	206 -
Stage 2	-	-	-	-	316 -
Critical Hdwy	4.13	-	-	-	5 4.5
Critical Hdwy Stg 1	-	-	-	-	5 -
Critical Hdwy Stg 2	-	-	-	-	5 -
Follow-up Hdwy	2.227	-	-	-	3 3
Pot Cap-1 Maneuver	1333	-	-	-	717 1010
Stage 1	-	-	-	-	981 -
Stage 2	-	-	-	-	880 -
Platoon blocked, %		-	-	-	
Mov Cap-1 Maneuver	1289	-	-	-	631 976
Mov Cap-2 Maneuver	-	-	-	-	631 -
Stage 1	-	-	-	-	893 -
Stage 2	-	-	-	-	851 -

Approach	EB	WB	SB
HCM Control Delay, s/v	2.17	0	9.28
HCM LOS			A

Minor Lane/Major Mvmt	EBL	EBT	WBT	WBR	SBLn1	SBLn2
Capacity (veh/h)	491	-	-	-	631	976
HCM Lane V/C Ratio	0.052	-	-	-	0.006	0.01
HCM Control Delay (s/veh)	7.9	0	-	-	10.7	8.7
HCM Lane LOS	A	A	-	-	B	A
HCM 95th %tile Q(veh)	0.2	-	-	-	0	0

103: Washington Avenue & 16 Street



Lane Group	EBL	EBT	WBL	WBT	WBR	NBL	NBT	SBL	SBT
Lane Configurations		↔		↕	↗	↖	↕↔	↖	↕↔
Traffic Volume (vph)	31	87	27	52	42	33	224	84	329
Future Volume (vph)	31	87	27	52	42	33	224	84	329
Turn Type	Perm	NA	Perm	NA	pm+ov	Perm	NA	pm+pt	NA
Protected Phases		8		4	5		6	5	2
Permitted Phases	8		4		4	6		2	
Detector Phase	8	8	4	4	5	6	6	5	2
Switch Phase									
Minimum Initial (s)	7.0	7.0	7.0	7.0	5.0	7.0	7.0	5.0	7.0
Minimum Split (s)	39.0	39.0	39.0	39.0	11.0	27.0	27.0	11.0	27.0
Total Split (s)	39.0	39.0	39.0	39.0	11.0	50.0	50.0	11.0	61.0
Total Split (%)	39.0%	39.0%	39.0%	39.0%	11.0%	50.0%	50.0%	11.0%	61.0%
Maximum Green (s)	33.0	33.0	33.0	33.0	5.0	44.0	44.0	5.0	55.0
Yellow Time (s)	4.0	4.0	4.0	4.0	4.0	4.0	4.0	4.0	4.0
All-Red Time (s)	2.0	2.0	2.0	2.0	2.0	2.0	2.0	2.0	2.0
Lost Time Adjust (s)		0.0		0.0	0.0	0.0	0.0	0.0	0.0
Total Lost Time (s)		6.0		6.0	6.0	6.0	6.0	6.0	6.0
Lead/Lag					Lead	Lag	Lag	Lead	
Lead-Lag Optimize?					Yes	Yes	Yes	Yes	
Vehicle Extension (s)	2.5	2.5	2.5	2.5	2.0	1.0	1.0	2.0	1.0
Recall Mode	None	None	None	None	None	C-Max	C-Max	None	C-Max
Walk Time (s)	5.0	5.0	5.0	5.0		7.0	7.0		7.0
Flash Don't Walk (s)	28.0	28.0	28.0	28.0		14.0	14.0		14.0
Pedestrian Calls (#/hr)	100	100	100	100		100	100		100

Intersection Summary

Cycle Length: 100
 Actuated Cycle Length: 100
 Offset: 1 (1%), Referenced to phase 2:SBTL and 6:NBTL, Start of Yellow
 Natural Cycle: 80
 Control Type: Actuated-Coordinated

Splits and Phases: 103: Washington Avenue & 16 Street



103: Washington Avenue & 16 Street



Lane Group	EBT	WBT	WBR	NBL	NBT	SBL	SBT
Lane Group Flow (vph)	187	102	54	42	379	108	522
v/c Ratio	0.38	0.22	0.10	0.14	0.28	0.26	0.30
Control Delay (s/veh)	26.8	25.8	5.2	18.4	15.8	12.7	11.5
Queue Delay	0.0	0.0	0.0	0.0	0.0	0.0	0.0
Total Delay (s/veh)	26.8	25.8	5.2	18.4	15.8	12.7	11.5
Queue Length 50th (ft)	84	47	0	16	66	32	80
Queue Length 95th (ft)	122	75	16	33	82	50	93
Internal Link Dist (ft)	170	490			200		499
Turn Bay Length (ft)				120		100	
Base Capacity (vph)	487	467	522	300	1359	413	1720
Starvation Cap Reductn	0	0	0	0	0	0	0
Spillback Cap Reductn	0	0	0	0	0	0	0
Storage Cap Reductn	0	0	0	0	0	0	0
Reduced v/c Ratio	0.38	0.22	0.10	0.14	0.28	0.26	0.30

Intersection Summary

HCM 7th Signalized Intersection Summary
 103: Washington Avenue & 16 Street

07/11/2025

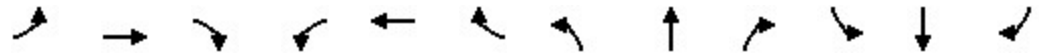

Movement	EBL	EBT	EBR	WBL	WBT	WBR	NBL	NBT	NBR	SBL	SBT	SBR
Lane Configurations		↕			↕	↗	↖	↕	↕	↖	↗	
Traffic Volume (veh/h)	31	87	27	27	52	42	33	224	72	84	329	78
Future Volume (veh/h)	31	87	27	27	52	42	33	224	72	84	329	78
Initial Q (Qb), veh	0	0	0	0	0	0	0	0	0	0	0	0
Lane Width Adj.	1.00	1.00	1.00	1.00	1.00	1.00	1.00	1.00	1.00	1.00	1.00	1.00
Ped-Bike Adj(A_pbT)	0.93		0.89	0.93		0.91	0.95		0.87	0.96		0.90
Parking Bus, Adj	1.00	1.00	0.90	1.00	1.00	0.90	1.00	1.00	0.90	1.00	1.00	0.90
Work Zone On Approach		No			No			No			No	
Adj Sat Flow, veh/h/ln	1856	1856	1856	1856	1856	1856	1856	1856	1856	1856	1856	1856
Adj Flow Rate, veh/h	40	112	35	35	67	54	42	287	92	108	422	100
Peak Hour Factor	0.78	0.78	0.78	0.78	0.78	0.78	0.78	0.78	0.78	0.78	0.78	0.78
Percent Heavy Veh, %	3	3	3	3	3	3	3	3	3	3	3	3
Cap, veh/h	118	300	86	196	353	476	448	1100	338	537	1477	344
Arrive On Green	0.32	0.32	0.32	0.32	0.32	0.32	0.60	0.60	0.60	0.06	0.75	0.75
Sat Flow, veh/h	233	942	271	464	1111	1282	829	2426	745	1767	2627	612
Grp Volume(v), veh/h	187	0	0	102	0	54	42	205	174	108	281	241
Grp Sat Flow(s),veh/h/ln	1446	0	0	1575	0	1282	829	1763	1408	1767	1763	1476
Q Serve(g_s), s	2.3	0.0	0.0	0.0	0.0	2.8	2.2	5.5	5.9	3.1	5.1	5.3
Cycle Q Clear(g_c), s	9.5	0.0	0.0	4.0	0.0	2.8	2.2	5.5	5.9	3.1	5.1	5.3
Prop In Lane	0.21		0.19	0.34		1.00	1.00		0.53	1.00		0.41
Lane Grp Cap(c), veh/h	503	0	0	549	0	476	448	799	639	537	991	830
V/C Ratio(X)	0.37	0.00	0.00	0.19	0.00	0.11	0.09	0.26	0.27	0.20	0.28	0.29
Avail Cap(c_a), veh/h	520	0	0	568	0	492	448	799	639	539	991	830
HCM Platoon Ratio	1.00	1.00	1.00	1.00	1.00	1.00	1.33	1.33	1.33	1.33	1.33	1.33
Upstream Filter(I)	1.00	0.00	0.00	1.00	0.00	1.00	1.00	1.00	1.00	1.00	1.00	1.00
Uniform Delay (d), s/veh	26.4	0.0	0.0	24.6	0.0	20.9	11.3	11.9	12.0	12.3	6.2	6.2
Incr Delay (d2), s/veh	0.3	0.0	0.0	0.1	0.0	0.1	0.4	0.8	1.1	0.1	0.7	0.9
Initial Q Delay(d3), s/veh	0.0	0.0	0.0	0.0	0.0	0.0	0.0	0.0	0.0	0.0	0.0	0.0
%ile BackOfQ(95%),veh/ln	6.2	0.0	0.0	3.2	0.0	1.5	0.8	3.8	3.3	2.1	3.3	2.9
Unsig. Movement Delay, s/veh												
LnGrp Delay(d), s/veh	26.8	0.0	0.0	24.7	0.0	21.0	11.7	12.7	13.1	12.4	6.9	7.1
LnGrp LOS	C			C		C	B	B	B	B	A	A
Approach Vol, veh/h		187			156			421			630	
Approach Delay, s/veh		26.8			23.5			12.8			7.9	
Approach LOS		C			C			B			A	
Timer - Assigned Phs		2		4	5	6		8				
Phs Duration (G+Y+Rc), s		62.2		37.8	10.9	51.3		37.8				
Change Period (Y+Rc), s		6.0		6.0	6.0	6.0		6.0				
Max Green Setting (Gmax), s		55.0		33.0	5.0	44.0		33.0				
Max Q Clear Time (g_c+I1), s		7.3		6.0	5.1	7.9		11.5				
Green Ext Time (p_c), s		1.1		0.6	0.0	0.9		0.9				
Intersection Summary												
HCM 7th Control Delay, s/veh				13.6								
HCM 7th LOS				B								

104: Collins Ave & 16 Street

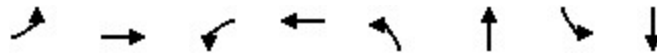

Lane Group	EBL	EBT	WBL	WBT	NBL	NBT	SBL	SBT
Lane Configurations								
Traffic Volume (vph)	52	3	2	6	27	310	13	395
Future Volume (vph)	52	3	2	6	27	310	13	395
Turn Type	Perm	NA	Perm	NA	Perm	NA	Perm	NA
Protected Phases		8		4		6		2
Permitted Phases	8		4		6		2	
Detector Phase	8	8	4	4	6	6	2	2
Switch Phase								
Minimum Initial (s)	7.0	7.0	7.0	7.0	5.0	5.0	5.0	5.0
Minimum Split (s)	26.2	26.2	26.2	26.2	34.2	34.2	34.2	34.2
Total Split (s)	30.0	30.0	30.0	30.0	70.0	70.0	70.0	70.0
Total Split (%)	30.0%	30.0%	30.0%	30.0%	70.0%	70.0%	70.0%	70.0%
Maximum Green (s)	24.0	24.0	24.0	24.0	63.8	63.8	63.8	63.8
Yellow Time (s)	4.0	4.0	4.0	4.0	4.0	4.0	4.0	4.0
All-Red Time (s)	2.0	2.0	2.0	2.0	2.2	2.2	2.2	2.2
Lost Time Adjust (s)	0.0	0.0	0.0	0.0		0.0		0.0
Total Lost Time (s)	6.0	6.0	6.0	6.0		6.2		6.2
Lead/Lag								
Lead-Lag Optimize?								
Vehicle Extension (s)	2.5	2.5	2.5	2.5	1.0	1.0	1.0	1.0
Recall Mode	None	None	None	None	C-Max	C-Max	C-Max	C-Max
Walk Time (s)	7.0	7.0	7.0	7.0	7.0	7.0	7.0	7.0
Flash Don't Walk (s)	13.0	13.0	13.0	13.0	21.0	21.0	21.0	21.0
Pedestrian Calls (#/hr)	100	100	100	100	100	100	100	100

Intersection Summary

Cycle Length: 100
 Actuated Cycle Length: 100
 Offset: 74 (74%), Referenced to phase 2:SBTL and 6:NBTL, Start of Yellow
 Natural Cycle: 65
 Control Type: Actuated-Coordinated

Splits and Phases: 104: Collins Ave & 16 Street

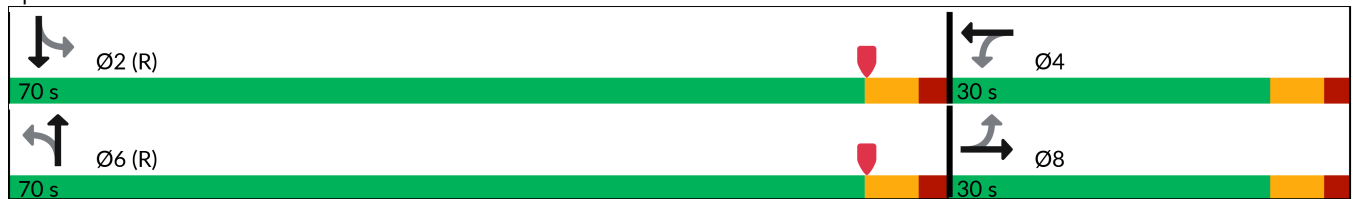

Queues

07/11/2025

104: Collins Ave & 16 Street



Lane Group	EBL	EBT	WBL	WBT	NBT	SBT
Lane Group Flow (vph)	54	135	2	15	354	534
v/c Ratio	0.33	0.43	0.01	0.07	0.18	0.28
Control Delay (s/veh)	40.2	11.1	32.5	22.4	5.7	5.5
Queue Delay	0.0	0.0	0.0	0.0	0.0	0.0
Total Delay (s/veh)	40.2	11.1	32.5	22.4	5.7	5.5
Queue Length 50th (ft)	29	2	1	3	38	53
Queue Length 95th (ft)	67	52	7	21	55	77
Internal Link Dist (ft)		784		333	896	387
Turn Bay Length (ft)	70					
Base Capacity (vph)	228	384	219	302	1944	1928
Starvation Cap Reductn	0	0	0	0	0	0
Spillback Cap Reductn	0	0	0	0	0	0
Storage Cap Reductn	0	0	0	0	0	0
Reduced v/c Ratio	0.24	0.35	0.01	0.05	0.18	0.28

Intersection Summary

HCM 7th Signalized Intersection Summary
 104: Collins Ave & 16 Street

07/11/2025

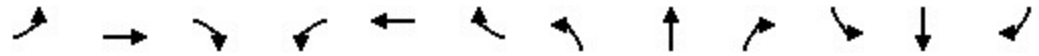

Movement	EBL	EBT	EBR	WBL	WBT	WBR	NBL	NBT	NBR	SBL	SBT	SBR
Lane Configurations	↖	↗		↖	↗			↕			↕	
Traffic Volume (veh/h)	52	3	128	2	6	9	27	310	6	13	395	111
Future Volume (veh/h)	52	3	128	2	6	9	27	310	6	13	395	111
Initial Q (Qb), veh	0	0	0	0	0	0	0	0	0	0	0	0
Lane Width Adj.	1.00	1.00	1.00	1.00	1.00	1.00	1.00	1.00	1.00	1.00	1.00	1.00
Ped-Bike Adj(A_pbT)	0.85		0.84	0.91		0.85	0.95		0.87	0.94		0.88
Parking Bus, Adj	1.00	1.00	0.90	1.00	1.00	0.90	1.00	1.00	0.90	1.00	1.00	0.90
Work Zone On Approach		No			No			No			No	
Adj Sat Flow, veh/h/ln	1670	1670	1670	1670	1670	1670	1670	1670	1670	1670	1670	1670
Adj Flow Rate, veh/h	54	3	132	2	6	9	28	320	6	13	407	114
Peak Hour Factor	0.97	0.97	0.97	0.97	0.97	0.97	0.97	0.97	0.97	0.97	0.97	0.97
Percent Heavy Veh, %	3	3	3	3	3	3	3	3	3	3	3	3
Cap, veh/h	271	5	206	155	96	143	161	1760	33	60	1487	402
Arrive On Green	0.20	0.20	0.20	0.20	0.20	0.20	0.91	0.91	0.91	0.91	0.91	0.91
Sat Flow, veh/h	1067	24	1050	1020	487	730	175	2583	49	33	2182	590
Grp Volume(v), veh/h	54	0	135	2	0	15	188	0	166	309	0	225
Grp Sat Flow(s),veh/h/ln	1067	0	1074	1020	0	1216	1456	0	1351	1641	0	1164
Q Serve(g_s), s	4.3	0.0	11.6	0.2	0.0	1.0	0.0	0.0	1.4	0.0	0.0	2.4
Cycle Q Clear(g_c), s	5.3	0.0	11.6	11.7	0.0	1.0	1.2	0.0	1.4	2.3	0.0	2.4
Prop In Lane	1.00		0.98	1.00		0.60	0.15		0.04	0.04		0.51
Lane Grp Cap(c), veh/h	271	0	211	155	0	239	1033	0	920	1155	0	793
V/C Ratio(X)	0.20	0.00	0.64	0.01	0.00	0.06	0.18	0.00	0.18	0.27	0.00	0.28
Avail Cap(c_a), veh/h	317	0	258	199	0	292	1033	0	920	1155	0	793
HCM Platoon Ratio	1.00	1.00	1.00	1.00	1.00	1.00	1.33	1.33	1.33	1.33	1.33	1.33
Upstream Filter(I)	1.00	0.00	1.00	1.00	0.00	1.00	1.00	0.00	1.00	1.00	0.00	1.00
Uniform Delay (d), s/veh	34.9	0.0	36.9	42.3	0.0	32.7	1.6	0.0	1.6	1.6	0.0	1.6
Incr Delay (d2), s/veh	0.3	0.0	3.0	0.0	0.0	0.1	0.4	0.0	0.4	0.6	0.0	0.9
Initial Q Delay(d3), s/veh	0.0	0.0	0.0	0.0	0.0	0.0	0.0	0.0	0.0	0.0	0.0	0.0
%ile BackOfQ(95%),veh/ln	2.1	0.0	5.7	0.1	0.0	0.5	0.8	0.0	0.7	1.4	0.0	1.1
Unsig. Movement Delay, s/veh												
LnGrp Delay(d), s/veh	35.1	0.0	39.9	42.3	0.0	32.8	1.9	0.0	2.0	2.2	0.0	2.5
LnGrp LOS	D		D	D		C	A		A	A		A
Approach Vol, veh/h		189			17			354				534
Approach Delay, s/veh		38.5			33.9			2.0				2.3
Approach LOS		D			C			A				A
Timer - Assigned Phs		2		4		6		8				
Phs Duration (G+Y+Rc), s		74.3		25.7		74.3		25.7				
Change Period (Y+Rc), s		6.2		6.0		6.2		6.0				
Max Green Setting (Gmax), s		63.8		24.0		63.8		24.0				
Max Q Clear Time (g_c+I1), s		4.4		13.7		3.4		13.6				
Green Ext Time (p_c), s		1.3		0.0		0.8		0.6				
Intersection Summary												
HCM 7th Control Delay, s/veh			8.9									
HCM 7th LOS			A									

Timings
101: Drexel Avenue & 16 Street

07/11/2025

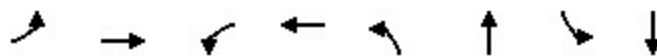

Lane Group	EBL	EBT	WBL	WBT	NBL	NBT	SBL	SBT	Ø7
Lane Configurations		↕		↕		↕		↕	
Traffic Volume (vph)	10	188	6	111	12	2	2	2	
Future Volume (vph)	10	188	6	111	12	2	2	2	
Turn Type	Perm	NA	Perm	NA	Perm	NA	Perm	NA	
Protected Phases		6		2		4		8	7
Permitted Phases	6		2		4		8		
Detector Phase	6	6	2	2	4	4	8	8	
Switch Phase									
Minimum Initial (s)	16.0	16.0	16.0	16.0	7.0	7.0	7.0	7.0	1.0
Minimum Split (s)	46.0	46.0	46.0	46.0	32.0	32.0	32.0	32.0	67.0
Total Split (s)	46.0	46.0	46.0	46.0	28.0	28.0	28.0	28.0	56.0
Total Split (%)	35.4%	35.4%	35.4%	35.4%	21.5%	21.5%	21.5%	21.5%	43%
Maximum Green (s)	40.0	40.0	40.0	40.0	22.0	22.0	22.0	22.0	50.0
Yellow Time (s)	4.0	4.0	4.0	4.0	4.0	4.0	4.0	4.0	4.0
All-Red Time (s)	2.0	2.0	2.0	2.0	2.0	2.0	2.0	2.0	2.0
Lost Time Adjust (s)		0.0		0.0		0.0		0.0	
Total Lost Time (s)		6.0		6.0		6.0		6.0	
Lead/Lag									
Lead-Lag Optimize?									
Vehicle Extension (s)	1.0	1.0	1.0	1.0	2.5	2.5	2.5	2.5	0.2
Recall Mode	Max	Max	Max	Max	None	None	None	None	None
Walk Time (s)	5.0	5.0	5.0	5.0	5.0	5.0	5.0	5.0	5.0
Flash Don't Walk (s)	21.0	21.0	21.0	21.0	21.0	21.0	21.0	21.0	56.0
Pedestrian Calls (#/hr)	63	63	63	63	31	31	31	31	3

Intersection Summary

Cycle Length: 130
 Actuated Cycle Length: 90.6
 Natural Cycle: 145
 Control Type: Actuated-Uncoordinated

Splits and Phases: 101: Drexel Avenue & 16 Street

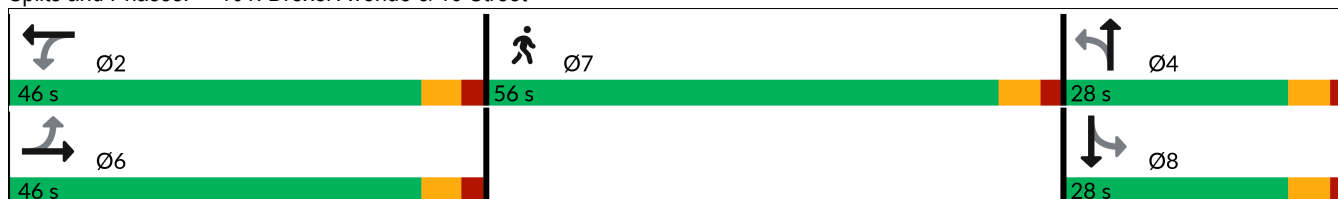

101: Drexel Avenue & 16 Street

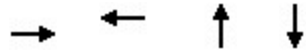

















Lane Group	EBT	WBT	NBT	SBT
Lane Group Flow (vph)	267	167	35	9
v/c Ratio	0.24	0.15	0.13	0.03
Control Delay (s/veh)	19.3	18.7	26.0	32.0
Queue Delay	0.0	0.0	0.0	0.0
Total Delay (s/veh)	19.3	18.7	26.0	32.0
Queue Length 50th (ft)	71	41	8	3
Queue Length 95th (ft)	257	161	38	18
Internal Link Dist (ft)	176	70	207	304
Turn Bay Length (ft)				
Base Capacity (vph)	1121	1110	388	414
Starvation Cap Reductn	0	0	0	0
Spillback Cap Reductn	0	0	0	0
Storage Cap Reductn	0	0	0	0
Reduced v/c Ratio	0.24	0.15	0.09	0.02

Intersection Summary

HCM Signalized Intersection Capacity Analysis
 101: Drexel Avenue & 16 Street

07/11/2025

												
Movement	EBL	EBT	EBR	WBL	WBT	WBR	NBL	NBT	NBR	SBL	SBT	SBR
Lane Configurations												
Traffic Volume (vph)	10	188	5	6	111	10	12	2	12	2	2	2
Future Volume (vph)	10	188	5	6	111	10	12	2	12	2	2	2
Ideal Flow (vphp)	1900	1900	1900	1900	1900	1900	1900	1900	1900	1900	1900	1900
Total Lost time (s)		6.0			6.0			6.0			6.0	
Lane Util. Factor		1.00			1.00			1.00			1.00	
Frbp, ped/bikes		1.00			0.99			0.97			0.98	
Flpb, ped/bikes		1.00			1.00			0.99			0.99	
Frt		1.00			0.99			0.94			0.96	
Flt Protected		1.00			1.00			0.98			0.98	
Satd. Flow (prot)		1643			1625			1463			1515	
Flt Permitted		0.99			0.99			0.87			0.92	
Satd. Flow (perm)		1624			1605			1305			1423	
Peak-hour factor, PHF	0.76	0.76	0.76	0.76	0.76	0.76	0.76	0.76	0.76	0.76	0.76	0.76
Adj. Flow (vph)	13	247	7	8	146	13	16	3	16	3	3	3
RTOR Reduction (vph)	0	0	0	0	1	0	0	14	0	0	3	0
Lane Group Flow (vph)	0	267	0	0	166	0	0	21	0	0	6	0
Confl. Peds. (#/hr)	31		39	39		31	16		19	19		16
Confl. Bikes (#/hr)			2			3			1			1
Parking (#/hr)	0	0	0	0	0	0	0	0	0	0	0	0
Turn Type	Perm	NA		Perm	NA		Perm	NA		Perm	NA	
Protected Phases		6			2			4			8	
Permitted Phases	6			2			4			8		
Actuated Green, G (s)		59.1			59.1			13.4			13.4	
Effective Green, g (s)		59.1			59.1			13.4			13.4	
Actuated g/C Ratio		0.60			0.60			0.14			0.14	
Clearance Time (s)		6.0			6.0			6.0			6.0	
Vehicle Extension (s)		1.0			1.0			2.5			2.5	
Lane Grp Cap (vph)		978			966			178			194	
v/s Ratio Prot												
v/s Ratio Perm		c0.16			0.10			c0.02			0.00	
v/c Ratio		0.27			0.17			0.12			0.03	
Uniform Delay, d1		9.3			8.6			37.2			36.7	
Progression Factor		1.00			1.00			1.00			1.00	
Incremental Delay, d2		0.7			0.4			0.2			0.1	
Delay (s)		10.0			9.0			37.4			36.8	
Level of Service		A			A			D			D	
Approach Delay (s/veh)		10.0			9.0			37.4			36.8	
Approach LOS		A			A			D			D	
Intersection Summary												
HCM 2000 Control Delay (s/veh)			12.2									B
HCM 2000 Volume to Capacity ratio			0.22									
Actuated Cycle Length (s)			98.1							18.0		
Intersection Capacity Utilization			44.9%									A
Analysis Period (min)			15									
c Critical Lane Group												

HCM 7th Edition methodology does not support exclusive ped or hold phases.

Intersection						
Int Delay, s/veh	1.5					
Movement	EBL	EBT	WBT	WBR	SBL	SBR
Lane Configurations		↶	↷		↶	↷
Traffic Vol, veh/h	54	144	114	37	3	8
Future Vol, veh/h	54	144	114	37	3	8
Conflicting Peds, #/hr	40	0	0	40	1	0
Sign Control	Free	Free	Free	Free	Stop	Stop
RT Channelized	-	None	-	None	-	None
Storage Length	-	-	-	-	0	0
Veh in Median Storage, #	-	0	0	-	0	-
Grade, %	-	0	0	-	0	-
Peak Hour Factor	80	80	80	80	80	80
Heavy Vehicles, %	3	3	3	3	3	3
Mvmt Flow	68	180	143	46	4	10

Major/Minor	Major1	Major2	Minor2		
Conflicting Flow All	229	0	-	0	522 206
Stage 1	-	-	-	-	206 -
Stage 2	-	-	-	-	316 -
Critical Hdwy	4.13	-	-	-	5 4.5
Critical Hdwy Stg 1	-	-	-	-	5 -
Critical Hdwy Stg 2	-	-	-	-	5 -
Follow-up Hdwy	2.227	-	-	-	3 3
Pot Cap-1 Maneuver	1333	-	-	-	717 1010
Stage 1	-	-	-	-	981 -
Stage 2	-	-	-	-	880 -
Platoon blocked, %		-	-	-	
Mov Cap-1 Maneuver	1289	-	-	-	631 976
Mov Cap-2 Maneuver	-	-	-	-	631 -
Stage 1	-	-	-	-	893 -
Stage 2	-	-	-	-	851 -

Approach	EB	WB	SB
HCM Control Delay, s/v	2.17	0	9.28
HCM LOS			A

Minor Lane/Major Mvmt	EBL	EBT	WBT	WBR	SBLn1	SBLn2
Capacity (veh/h)	491	-	-	-	631	976
HCM Lane V/C Ratio	0.052	-	-	-	0.006	0.01
HCM Control Delay (s/veh)	7.9	0	-	-	10.7	8.7
HCM Lane LOS	A	A	-	-	B	A
HCM 95th %tile Q(veh)	0.2	-	-	-	0	0

103: Washington Avenue & 16 Street



Lane Group	EBL	EBT	WBL	WBT	WBR	NBL	NBT	SBL	SBT
Lane Configurations		↔		↕	↗	↖	↕↗	↖	↕↗
Traffic Volume (vph)	31	87	27	52	42	33	224	84	329
Future Volume (vph)	31	87	27	52	42	33	224	84	329
Turn Type	Perm	NA	Perm	NA	pm+ov	Perm	NA	pm+pt	NA
Protected Phases		8		4	5		6	5	2
Permitted Phases	8		4		4	6		2	
Detector Phase	8	8	4	4	5	6	6	5	2
Switch Phase									
Minimum Initial (s)	7.0	7.0	7.0	7.0	5.0	7.0	7.0	5.0	7.0
Minimum Split (s)	39.0	39.0	39.0	39.0	11.0	27.0	27.0	11.0	27.0
Total Split (s)	39.0	39.0	39.0	39.0	11.0	50.0	50.0	11.0	61.0
Total Split (%)	39.0%	39.0%	39.0%	39.0%	11.0%	50.0%	50.0%	11.0%	61.0%
Maximum Green (s)	33.0	33.0	33.0	33.0	5.0	44.0	44.0	5.0	55.0
Yellow Time (s)	4.0	4.0	4.0	4.0	4.0	4.0	4.0	4.0	4.0
All-Red Time (s)	2.0	2.0	2.0	2.0	2.0	2.0	2.0	2.0	2.0
Lost Time Adjust (s)		0.0		0.0	0.0	0.0	0.0	0.0	0.0
Total Lost Time (s)		6.0		6.0	6.0	6.0	6.0	6.0	6.0
Lead/Lag					Lead	Lag	Lag	Lead	
Lead-Lag Optimize?					Yes	Yes	Yes	Yes	
Vehicle Extension (s)	2.5	2.5	2.5	2.5	2.0	1.0	1.0	2.0	1.0
Recall Mode	None	None	None	None	None	C-Max	C-Max	None	C-Max
Walk Time (s)	5.0	5.0	5.0	5.0		7.0	7.0		7.0
Flash Don't Walk (s)	28.0	28.0	28.0	28.0		14.0	14.0		14.0
Pedestrian Calls (#/hr)	100	100	100	100		100	100		100

Intersection Summary

Cycle Length: 100
 Actuated Cycle Length: 100
 Offset: 1 (1%), Referenced to phase 2:SBTL and 6:NBTL, Start of Yellow
 Natural Cycle: 80
 Control Type: Actuated-Coordinated

Splits and Phases: 103: Washington Avenue & 16 Street



103: Washington Avenue & 16 Street



Lane Group	EBT	WBT	WBR	NBL	NBT	SBL	SBT
Lane Group Flow (vph)	187	102	54	42	379	108	522
v/c Ratio	0.38	0.22	0.10	0.14	0.28	0.26	0.30
Control Delay (s/veh)	26.8	25.8	5.2	18.4	15.8	12.7	11.5
Queue Delay	0.0	0.0	0.0	0.0	0.0	0.0	0.0
Total Delay (s/veh)	26.8	25.8	5.2	18.4	15.8	12.7	11.5
Queue Length 50th (ft)	84	47	0	16	66	32	80
Queue Length 95th (ft)	122	75	16	33	82	50	93
Internal Link Dist (ft)	170	490			200		499
Turn Bay Length (ft)				120		100	
Base Capacity (vph)	487	467	522	300	1359	413	1720
Starvation Cap Reductn	0	0	0	0	0	0	0
Spillback Cap Reductn	0	0	0	0	0	0	0
Storage Cap Reductn	0	0	0	0	0	0	0
Reduced v/c Ratio	0.38	0.22	0.10	0.14	0.28	0.26	0.30

Intersection Summary

HCM 7th Signalized Intersection Summary
 103: Washington Avenue & 16 Street

07/11/2025

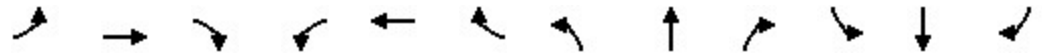

Movement	EBL	EBT	EBR	WBL	WBT	WBR	NBL	NBT	NBR	SBL	SBT	SBR
Lane Configurations		↔			↕	↗	↖	↕		↖	↕	↗
Traffic Volume (veh/h)	31	87	27	27	52	42	33	224	72	84	329	78
Future Volume (veh/h)	31	87	27	27	52	42	33	224	72	84	329	78
Initial Q (Qb), veh	0	0	0	0	0	0	0	0	0	0	0	0
Lane Width Adj.	1.00	1.00	1.00	1.00	1.00	1.00	1.00	1.00	1.00	1.00	1.00	1.00
Ped-Bike Adj(A_pbT)	0.93		0.89	0.93		0.91	0.95		0.87	0.96		0.90
Parking Bus, Adj	1.00	1.00	0.90	1.00	1.00	0.90	1.00	1.00	0.90	1.00	1.00	0.90
Work Zone On Approach		No			No			No			No	
Adj Sat Flow, veh/h/ln	1856	1856	1856	1856	1856	1856	1856	1856	1856	1856	1856	1856
Adj Flow Rate, veh/h	40	112	35	35	67	54	42	287	92	108	422	100
Peak Hour Factor	0.78	0.78	0.78	0.78	0.78	0.78	0.78	0.78	0.78	0.78	0.78	0.78
Percent Heavy Veh, %	3	3	3	3	3	3	3	3	3	3	3	3
Cap, veh/h	118	300	86	196	353	476	448	1100	338	537	1477	344
Arrive On Green	0.32	0.32	0.32	0.32	0.32	0.32	0.60	0.60	0.60	0.06	0.75	0.75
Sat Flow, veh/h	233	942	271	464	1111	1282	829	2426	745	1767	2627	612
Grp Volume(v), veh/h	187	0	0	102	0	54	42	205	174	108	281	241
Grp Sat Flow(s),veh/h/ln	1446	0	0	1575	0	1282	829	1763	1408	1767	1763	1476
Q Serve(g_s), s	2.3	0.0	0.0	0.0	0.0	2.8	2.2	5.5	5.9	3.1	5.1	5.3
Cycle Q Clear(g_c), s	9.5	0.0	0.0	4.0	0.0	2.8	2.2	5.5	5.9	3.1	5.1	5.3
Prop In Lane	0.21		0.19	0.34		1.00	1.00		0.53	1.00		0.41
Lane Grp Cap(c), veh/h	503	0	0	549	0	476	448	799	639	537	991	830
V/C Ratio(X)	0.37	0.00	0.00	0.19	0.00	0.11	0.09	0.26	0.27	0.20	0.28	0.29
Avail Cap(c_a), veh/h	520	0	0	568	0	492	448	799	639	539	991	830
HCM Platoon Ratio	1.00	1.00	1.00	1.00	1.00	1.00	1.33	1.33	1.33	1.33	1.33	1.33
Upstream Filter(I)	1.00	0.00	0.00	1.00	0.00	1.00	1.00	1.00	1.00	1.00	1.00	1.00
Uniform Delay (d), s/veh	26.4	0.0	0.0	24.6	0.0	20.9	11.3	11.9	12.0	12.3	6.2	6.2
Incr Delay (d2), s/veh	0.3	0.0	0.0	0.1	0.0	0.1	0.4	0.8	1.1	0.1	0.7	0.9
Initial Q Delay(d3), s/veh	0.0	0.0	0.0	0.0	0.0	0.0	0.0	0.0	0.0	0.0	0.0	0.0
%ile BackOfQ(95%),veh/ln	6.2	0.0	0.0	3.2	0.0	1.5	0.8	3.8	3.3	2.1	3.3	2.9
Unsig. Movement Delay, s/veh												
LnGrp Delay(d), s/veh	26.8	0.0	0.0	24.7	0.0	21.0	11.7	12.7	13.1	12.4	6.9	7.1
LnGrp LOS	C			C		C	B	B	B	B	A	A
Approach Vol, veh/h		187			156			421			630	
Approach Delay, s/veh		26.8			23.5			12.8			7.9	
Approach LOS		C			C			B			A	
Timer - Assigned Phs		2		4	5	6		8				
Phs Duration (G+Y+Rc), s		62.2		37.8	10.9	51.3		37.8				
Change Period (Y+Rc), s		6.0		6.0	6.0	6.0		6.0				
Max Green Setting (Gmax), s		55.0		33.0	5.0	44.0		33.0				
Max Q Clear Time (g_c+I1), s		7.3		6.0	5.1	7.9		11.5				
Green Ext Time (p_c), s		1.1		0.6	0.0	0.9		0.9				
Intersection Summary												
HCM 7th Control Delay, s/veh				13.6								
HCM 7th LOS				B								

104: Collins Ave & 16 Street

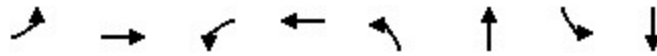

Lane Group	EBL	EBT	WBL	WBT	NBL	NBT	SBL	SBT
Lane Configurations								
Traffic Volume (vph)	52	3	2	6	27	310	13	395
Future Volume (vph)	52	3	2	6	27	310	13	395
Turn Type	Perm	NA	Perm	NA	Perm	NA	Perm	NA
Protected Phases		8		4		6		2
Permitted Phases	8		4		6		2	
Detector Phase	8	8	4	4	6	6	2	2
Switch Phase								
Minimum Initial (s)	7.0	7.0	7.0	7.0	5.0	5.0	5.0	5.0
Minimum Split (s)	26.2	26.2	26.2	26.2	34.2	34.2	34.2	34.2
Total Split (s)	30.0	30.0	30.0	30.0	70.0	70.0	70.0	70.0
Total Split (%)	30.0%	30.0%	30.0%	30.0%	70.0%	70.0%	70.0%	70.0%
Maximum Green (s)	24.0	24.0	24.0	24.0	63.8	63.8	63.8	63.8
Yellow Time (s)	4.0	4.0	4.0	4.0	4.0	4.0	4.0	4.0
All-Red Time (s)	2.0	2.0	2.0	2.0	2.2	2.2	2.2	2.2
Lost Time Adjust (s)	0.0	0.0	0.0	0.0		0.0		0.0
Total Lost Time (s)	6.0	6.0	6.0	6.0		6.2		6.2
Lead/Lag								
Lead-Lag Optimize?								
Vehicle Extension (s)	2.5	2.5	2.5	2.5	1.0	1.0	1.0	1.0
Recall Mode	None	None	None	None	C-Max	C-Max	C-Max	C-Max
Walk Time (s)	7.0	7.0	7.0	7.0	7.0	7.0	7.0	7.0
Flash Don't Walk (s)	13.0	13.0	13.0	13.0	21.0	21.0	21.0	21.0
Pedestrian Calls (#/hr)	100	100	100	100	100	100	100	100

Intersection Summary

Cycle Length: 100
 Actuated Cycle Length: 100
 Offset: 74 (74%), Referenced to phase 2:SBTL and 6:NBTL, Start of Yellow
 Natural Cycle: 65
 Control Type: Actuated-Coordinated

Splits and Phases: 104: Collins Ave & 16 Street

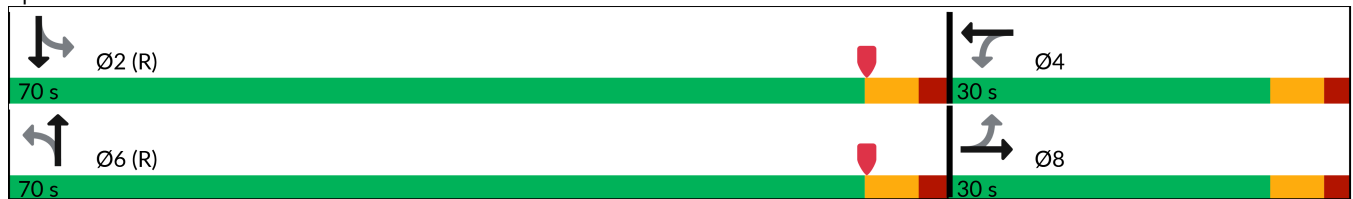

Queues

07/11/2025

104: Collins Ave & 16 Street



Lane Group	EBL	EBT	WBL	WBT	NBT	SBT
Lane Group Flow (vph)	54	135	2	15	354	534
v/c Ratio	0.33	0.43	0.01	0.07	0.18	0.28
Control Delay (s/veh)	40.2	11.1	32.5	22.4	5.7	5.5
Queue Delay	0.0	0.0	0.0	0.0	0.0	0.0
Total Delay (s/veh)	40.2	11.1	32.5	22.4	5.7	5.5
Queue Length 50th (ft)	29	2	1	3	38	53
Queue Length 95th (ft)	67	52	7	21	55	77
Internal Link Dist (ft)		784		333	896	387
Turn Bay Length (ft)	70					
Base Capacity (vph)	228	384	219	302	1944	1928
Starvation Cap Reductn	0	0	0	0	0	0
Spillback Cap Reductn	0	0	0	0	0	0
Storage Cap Reductn	0	0	0	0	0	0
Reduced v/c Ratio	0.24	0.35	0.01	0.05	0.18	0.28

Intersection Summary

HCM 7th Signalized Intersection Summary
 104: Collins Ave & 16 Street

07/11/2025



Movement	EBL	EBT	EBR	WBL	WBT	WBR	NBL	NBT	NBR	SBL	SBT	SBR
Lane Configurations	↖	↗		↖	↗			↕			↕	
Traffic Volume (veh/h)	52	3	128	2	6	9	27	310	6	13	395	111
Future Volume (veh/h)	52	3	128	2	6	9	27	310	6	13	395	111
Initial Q (Qb), veh	0	0	0	0	0	0	0	0	0	0	0	0
Lane Width Adj.	1.00	1.00	1.00	1.00	1.00	1.00	1.00	1.00	1.00	1.00	1.00	1.00
Ped-Bike Adj(A_pbT)	0.85		0.84	0.91		0.85	0.95		0.87	0.94		0.88
Parking Bus, Adj	1.00	1.00	0.90	1.00	1.00	0.90	1.00	1.00	0.90	1.00	1.00	0.90
Work Zone On Approach		No			No			No			No	
Adj Sat Flow, veh/h/ln	1670	1670	1670	1670	1670	1670	1670	1670	1670	1670	1670	1670
Adj Flow Rate, veh/h	54	3	132	2	6	9	28	320	6	13	407	114
Peak Hour Factor	0.97	0.97	0.97	0.97	0.97	0.97	0.97	0.97	0.97	0.97	0.97	0.97
Percent Heavy Veh, %	3	3	3	3	3	3	3	3	3	3	3	3
Cap, veh/h	271	5	206	155	96	143	161	1760	33	60	1487	402
Arrive On Green	0.20	0.20	0.20	0.20	0.20	0.20	0.91	0.91	0.91	0.91	0.91	0.91
Sat Flow, veh/h	1067	24	1050	1020	487	730	175	2583	49	33	2182	590
Grp Volume(v), veh/h	54	0	135	2	0	15	188	0	166	309	0	225
Grp Sat Flow(s),veh/h/ln	1067	0	1074	1020	0	1216	1456	0	1351	1641	0	1164
Q Serve(g_s), s	4.3	0.0	11.6	0.2	0.0	1.0	0.0	0.0	1.4	0.0	0.0	2.4
Cycle Q Clear(g_c), s	5.3	0.0	11.6	11.7	0.0	1.0	1.2	0.0	1.4	2.3	0.0	2.4
Prop In Lane	1.00		0.98	1.00		0.60	0.15		0.04	0.04		0.51
Lane Grp Cap(c), veh/h	271	0	211	155	0	239	1033	0	920	1155	0	793
V/C Ratio(X)	0.20	0.00	0.64	0.01	0.00	0.06	0.18	0.00	0.18	0.27	0.00	0.28
Avail Cap(c_a), veh/h	317	0	258	199	0	292	1033	0	920	1155	0	793
HCM Platoon Ratio	1.00	1.00	1.00	1.00	1.00	1.00	1.33	1.33	1.33	1.33	1.33	1.33
Upstream Filter(I)	1.00	0.00	1.00	1.00	0.00	1.00	1.00	0.00	1.00	1.00	0.00	1.00
Uniform Delay (d), s/veh	34.9	0.0	36.9	42.3	0.0	32.7	1.6	0.0	1.6	1.6	0.0	1.6
Incr Delay (d2), s/veh	0.3	0.0	3.0	0.0	0.0	0.1	0.4	0.0	0.4	0.6	0.0	0.9
Initial Q Delay(d3), s/veh	0.0	0.0	0.0	0.0	0.0	0.0	0.0	0.0	0.0	0.0	0.0	0.0
%ile BackOfQ(95%),veh/ln	2.1	0.0	5.7	0.1	0.0	0.5	0.8	0.0	0.7	1.4	0.0	1.1
Unsig. Movement Delay, s/veh												
LnGrp Delay(d), s/veh	35.1	0.0	39.9	42.3	0.0	32.8	1.9	0.0	2.0	2.2	0.0	2.5
LnGrp LOS	D		D	D		C	A		A	A		A
Approach Vol, veh/h		189			17			354				534
Approach Delay, s/veh		38.5			33.9			2.0				2.3
Approach LOS		D			C			A				A
Timer - Assigned Phs		2		4		6		8				
Phs Duration (G+Y+Rc), s		74.3		25.7		74.3		25.7				
Change Period (Y+Rc), s		6.2		6.0		6.2		6.0				
Max Green Setting (Gmax), s		63.8		24.0		63.8		24.0				
Max Q Clear Time (g_c+I1), s		4.4		13.7		3.4		13.6				
Green Ext Time (p_c), s		1.3		0.0		0.8		0.6				
Intersection Summary												
HCM 7th Control Delay, s/veh			8.9									
HCM 7th LOS			A									

Timings
101: Drexel Avenue & 16 Street

07/11/2025

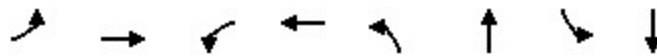

Lane Group	EBL	EBT	WBL	WBT	NBL	NBT	SBL	SBT	Ø7
Lane Configurations		↕		↕		↕		↕	
Traffic Volume (vph)	10	196	7	127	12	2	2	2	
Future Volume (vph)	10	196	7	127	12	2	2	2	
Turn Type	Perm	NA	Perm	NA	Perm	NA	Perm	NA	
Protected Phases		6		2		4		8	7
Permitted Phases	6		2		4		8		
Detector Phase	6	6	2	2	4	4	8	8	
Switch Phase									
Minimum Initial (s)	16.0	16.0	16.0	16.0	7.0	7.0	7.0	7.0	1.0
Minimum Split (s)	46.0	46.0	46.0	46.0	32.0	32.0	32.0	32.0	67.0
Total Split (s)	46.0	46.0	46.0	46.0	28.0	28.0	28.0	28.0	56.0
Total Split (%)	35.4%	35.4%	35.4%	35.4%	21.5%	21.5%	21.5%	21.5%	43%
Maximum Green (s)	40.0	40.0	40.0	40.0	22.0	22.0	22.0	22.0	50.0
Yellow Time (s)	4.0	4.0	4.0	4.0	4.0	4.0	4.0	4.0	4.0
All-Red Time (s)	2.0	2.0	2.0	2.0	2.0	2.0	2.0	2.0	2.0
Lost Time Adjust (s)		0.0		0.0		0.0		0.0	
Total Lost Time (s)		6.0		6.0		6.0		6.0	
Lead/Lag									
Lead-Lag Optimize?									
Vehicle Extension (s)	1.0	1.0	1.0	1.0	2.5	2.5	2.5	2.5	0.2
Recall Mode	Max	Max	Max	Max	None	None	None	None	None
Walk Time (s)	5.0	5.0	5.0	5.0	5.0	5.0	5.0	5.0	5.0
Flash Don't Walk (s)	21.0	21.0	21.0	21.0	21.0	21.0	21.0	21.0	56.0
Pedestrian Calls (#/hr)	63	63	63	63	31	31	31	31	3

Intersection Summary

Cycle Length: 130
 Actuated Cycle Length: 90.6
 Natural Cycle: 145
 Control Type: Actuated-Uncoordinated

Splits and Phases: 101: Drexel Avenue & 16 Street

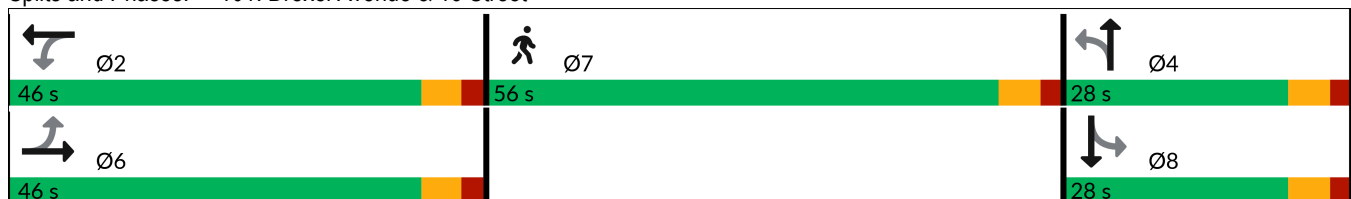

101: Drexel Avenue & 16 Street

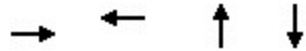

















Lane Group	EBT	WBT	NBT	SBT
Lane Group Flow (vph)	278	190	36	9
v/c Ratio	0.25	0.17	0.14	0.03
Control Delay (s/veh)	19.4	18.7	25.5	32.0
Queue Delay	0.0	0.0	0.0	0.0
Total Delay (s/veh)	19.4	18.7	25.5	32.0
Queue Length 50th (ft)	74	47	8	3
Queue Length 95th (ft)	268	182	39	18
Internal Link Dist (ft)	176	70	207	304
Turn Bay Length (ft)				
Base Capacity (vph)	1123	1110	389	414
Starvation Cap Reductn	0	0	0	0
Spillback Cap Reductn	0	0	0	0
Storage Cap Reductn	0	0	0	0
Reduced v/c Ratio	0.25	0.17	0.09	0.02

Intersection Summary

HCM Signalized Intersection Capacity Analysis
 101: Drexel Avenue & 16 Street

07/11/2025

													
Movement	EBL	EBT	EBR	WBL	WBT	WBR	NBL	NBT	NBR	SBL	SBT	SBR	
Lane Configurations													
Traffic Volume (vph)	10	196	5	7	127	11	12	2	13	2	2	2	
Future Volume (vph)	10	196	5	7	127	11	12	2	13	2	2	2	
Ideal Flow (vphpl)	1900	1900	1900	1900	1900	1900	1900	1900	1900	1900	1900	1900	
Total Lost time (s)		6.0			6.0			6.0			6.0		
Lane Util. Factor		1.00			1.00			1.00			1.00		
Frbp, ped/bikes		1.00			0.99			0.97			0.98		
Flpb, ped/bikes		1.00			1.00			0.99			0.99		
Frt		1.00			0.99			0.94			0.96		
Flt Protected		1.00			1.00			0.98			0.98		
Satd. Flow (prot)		1643			1627			1460			1515		
Flt Permitted		0.99			0.98			0.88			0.92		
Satd. Flow (perm)		1624			1605			1306			1422		
Peak-hour factor, PHF	0.76	0.76	0.76	0.76	0.76	0.76	0.76	0.76	0.76	0.76	0.76	0.76	
Adj. Flow (vph)	13	258	7	9	167	14	16	3	17	3	3	3	
RTOR Reduction (vph)	0	0	0	0	1	0	0	15	0	0	3	0	
Lane Group Flow (vph)	0	278	0	0	189	0	0	21	0	0	6	0	
Confl. Peds. (#/hr)	31		39	39		31	16		19	19		16	
Confl. Bikes (#/hr)			2			3			1			1	
Parking (#/hr)	0	0	0	0	0	0	0	0	0	0	0	0	
Turn Type	Perm	NA		Perm	NA		Perm	NA		Perm	NA		
Protected Phases		6			2			4			8		
Permitted Phases	6			2			4			8			
Actuated Green, G (s)		59.1			59.1			13.4			13.4		
Effective Green, g (s)		59.1			59.1			13.4			13.4		
Actuated g/C Ratio		0.60			0.60			0.14			0.14		
Clearance Time (s)		6.0			6.0			6.0			6.0		
Vehicle Extension (s)		1.0			1.0			2.5			2.5		
Lane Grp Cap (vph)		978			966			178			194		
v/s Ratio Prot													
v/s Ratio Perm		c0.17			0.12			c0.02			0.00		
v/c Ratio		0.28			0.20			0.12			0.03		
Uniform Delay, d1		9.4			8.8			37.2			36.7		
Progression Factor		1.00			1.00			1.00			1.00		
Incremental Delay, d2		0.7			0.5			0.2			0.1		
Delay (s)		10.1			9.2			37.4			36.8		
Level of Service		B			A			D			D		
Approach Delay (s/veh)		10.1			9.2			37.4			36.8		
Approach LOS		B			A			D			D		
Intersection Summary													
HCM 2000 Control Delay (s/veh)			12.2									HCM 2000 Level of Service	B
HCM 2000 Volume to Capacity ratio			0.23										
Actuated Cycle Length (s)			98.1									Sum of lost time (s)	18.0
Intersection Capacity Utilization			44.9%									ICU Level of Service	A
Analysis Period (min)			15										
c Critical Lane Group													

HCM 7th Edition methodology does not support exclusive ped or hold phases.

Intersection						
Int Delay, s/veh	2.4					
Movement	EBL	EBT	WBT	WBR	SBL	SBR
Lane Configurations		↶	↷		↶	↷
Traffic Vol, veh/h	62	144	114	48	26	26
Future Vol, veh/h	62	144	114	48	26	26
Conflicting Peds, #/hr	40	0	0	40	1	0
Sign Control	Free	Free	Free	Free	Stop	Stop
RT Channelized	-	None	-	None	-	None
Storage Length	-	-	-	-	0	0
Veh in Median Storage, #	-	0	0	-	0	-
Grade, %	-	0	0	-	0	-
Peak Hour Factor	80	80	80	80	80	80
Heavy Vehicles, %	3	3	3	3	3	3
Mvmt Flow	78	180	143	60	33	33

Major/Minor	Major1	Major2	Minor2		
Conflicting Flow All	243	0	-	0	549
Stage 1	-	-	-	-	213
Stage 2	-	-	-	-	336
Critical Hdwy	4.13	-	-	-	5
Critical Hdwy Stg 1	-	-	-	-	5
Critical Hdwy Stg 2	-	-	-	-	5
Follow-up Hdwy	2.227	-	-	-	3
Pot Cap-1 Maneuver	1318	-	-	-	698
Stage 1	-	-	-	-	975
Stage 2	-	-	-	-	863
Platoon blocked, %		-	-	-	
Mov Cap-1 Maneuver	1274	-	-	-	608
Mov Cap-2 Maneuver	-	-	-	-	608
Stage 1	-	-	-	-	879
Stage 2	-	-	-	-	834

Approach	EB	WB	SB
HCM Control Delay, s/v	2.41	0	10.05
HCM LOS			B

Minor Lane/Major Mvmt	EBL	EBT	WBT	WBR	SBLn1	SBLn2
Capacity (veh/h)	542	-	-	-	608	970
HCM Lane V/C Ratio	0.061	-	-	-	0.053	0.033
HCM Control Delay (s/veh)	8	0	-	-	11.3	8.8
HCM Lane LOS	A	A	-	-	B	A
HCM 95th %tile Q(veh)	0.2	-	-	-	0.2	0.1

103: Washington Avenue & 16 Street



Lane Group	EBL	EBT	WBL	WBT	WBR	NBL	NBT	SBL	SBT
Lane Configurations		↔		↑	↗	↖	↕	↖	↕
Traffic Volume (vph)	38	101	27	58	42	34	224	84	329
Future Volume (vph)	38	101	27	58	42	34	224	84	329
Turn Type	Perm	NA	Perm	NA	pm+ov	Perm	NA	pm+pt	NA
Protected Phases		8		4	5		6	5	2
Permitted Phases	8		4		4	6		2	
Detector Phase	8	8	4	4	5	6	6	5	2
Switch Phase									
Minimum Initial (s)	7.0	7.0	7.0	7.0	5.0	7.0	7.0	5.0	7.0
Minimum Split (s)	39.0	39.0	39.0	39.0	11.0	27.0	27.0	11.0	27.0
Total Split (s)	39.0	39.0	39.0	39.0	11.0	50.0	50.0	11.0	61.0
Total Split (%)	39.0%	39.0%	39.0%	39.0%	11.0%	50.0%	50.0%	11.0%	61.0%
Maximum Green (s)	33.0	33.0	33.0	33.0	5.0	44.0	44.0	5.0	55.0
Yellow Time (s)	4.0	4.0	4.0	4.0	4.0	4.0	4.0	4.0	4.0
All-Red Time (s)	2.0	2.0	2.0	2.0	2.0	2.0	2.0	2.0	2.0
Lost Time Adjust (s)		0.0		0.0	0.0	0.0	0.0	0.0	0.0
Total Lost Time (s)		6.0		6.0	6.0	6.0	6.0	6.0	6.0
Lead/Lag					Lead	Lag	Lag	Lead	
Lead-Lag Optimize?					Yes	Yes	Yes	Yes	
Vehicle Extension (s)	2.5	2.5	2.5	2.5	2.0	1.0	1.0	2.0	1.0
Recall Mode	None	None	None	None	None	C-Max	C-Max	None	C-Max
Walk Time (s)	5.0	5.0	5.0	5.0		7.0	7.0		7.0
Flash Don't Walk (s)	28.0	28.0	28.0	28.0		14.0	14.0		14.0
Pedestrian Calls (#/hr)	100	100	100	100		100	100		100

Intersection Summary

Cycle Length: 100
 Actuated Cycle Length: 100
 Offset: 1 (1%), Referenced to phase 2:SBTL and 6:NBTL, Start of Yellow
 Natural Cycle: 80
 Control Type: Actuated-Coordinated

Splits and Phases: 103: Washington Avenue & 16 Street



103: Washington Avenue & 16 Street



Lane Group	EBT	WBT	WBR	NBL	NBT	SBL	SBT
Lane Group Flow (vph)	215	109	54	44	379	108	526
v/c Ratio	0.45	0.23	0.10	0.15	0.28	0.26	0.31
Control Delay (s/veh)	28.5	26.0	5.2	18.5	15.8	12.7	11.5
Queue Delay	0.0	0.0	0.0	0.0	0.0	0.0	0.0
Total Delay (s/veh)	28.5	26.0	5.2	18.5	15.8	12.7	11.5
Queue Length 50th (ft)	101	50	0	16	66	32	81
Queue Length 95th (ft)	142	79	16	34	82	50	93
Internal Link Dist (ft)	170	490			200		499
Turn Bay Length (ft)				120		100	
Base Capacity (vph)	481	467	522	299	1359	413	1716
Starvation Cap Reductn	0	0	0	0	0	0	0
Spillback Cap Reductn	0	0	0	0	0	0	0
Storage Cap Reductn	0	0	0	0	0	0	0
Reduced v/c Ratio	0.45	0.23	0.10	0.15	0.28	0.26	0.31

Intersection Summary

HCM 7th Signalized Intersection Summary
 103: Washington Avenue & 16 Street

07/11/2025

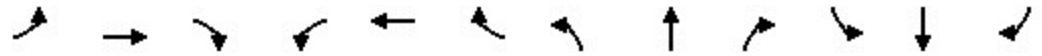

Movement	EBL	EBT	EBR	WBL	WBT	WBR	NBL	NBT	NBR	SBL	SBT	SBR
Lane Configurations		↕			↕	↕	↕	↕↔		↕	↕↔	
Traffic Volume (veh/h)	38	101	29	27	58	42	34	224	72	84	329	81
Future Volume (veh/h)	38	101	29	27	58	42	34	224	72	84	329	81
Initial Q (Qb), veh	0	0	0	0	0	0	0	0	0	0	0	0
Lane Width Adj.	1.00	1.00	1.00	1.00	1.00	1.00	1.00	1.00	1.00	1.00	1.00	1.00
Ped-Bike Adj(A_pbT)	0.93		0.90	0.94		0.91	0.95		0.87	0.96		0.90
Parking Bus, Adj	1.00	1.00	0.90	1.00	1.00	0.90	1.00	1.00	0.90	1.00	1.00	0.90
Work Zone On Approach		No			No			No			No	
Adj Sat Flow, veh/h/ln	1856	1856	1856	1856	1856	1856	1856	1856	1856	1856	1856	1856
Adj Flow Rate, veh/h	49	129	37	35	74	54	44	287	92	108	422	104
Peak Hour Factor	0.78	0.78	0.78	0.78	0.78	0.78	0.78	0.78	0.78	0.78	0.78	0.78
Percent Heavy Veh, %	3	3	3	3	3	3	3	3	3	3	3	3
Cap, veh/h	125	300	79	183	364	478	446	1097	337	536	1460	354
Arrive On Green	0.32	0.32	0.32	0.32	0.32	0.32	0.60	0.60	0.60	0.06	0.75	0.75
Sat Flow, veh/h	253	939	248	423	1140	1282	826	2426	745	1767	2603	630
Grp Volume(v), veh/h	215	0	0	109	0	54	44	205	174	108	283	243
Grp Sat Flow(s),veh/h/ln	1440	0	0	1563	0	1282	826	1763	1408	1767	1763	1470
Q Serve(g_s), s	4.7	0.0	0.0	0.0	0.0	2.8	2.3	5.5	5.9	3.1	5.2	5.4
Cycle Q Clear(g_c), s	11.3	0.0	0.0	4.3	0.0	2.8	2.3	5.5	5.9	3.1	5.2	5.4
Prop In Lane	0.23		0.17	0.32		1.00	1.00		0.53	1.00		0.43
Lane Grp Cap(c), veh/h	504	0	0	546	0	478	446	797	637	536	989	825
V/C Ratio(X)	0.43	0.00	0.00	0.20	0.00	0.11	0.10	0.26	0.27	0.20	0.29	0.29
Avail Cap(c_a), veh/h	519	0	0	563	0	492	446	797	637	538	989	825
HCM Platoon Ratio	1.00	1.00	1.00	1.00	1.00	1.00	1.33	1.33	1.33	1.33	1.33	1.33
Upstream Filter(I)	1.00	0.00	0.00	1.00	0.00	1.00	1.00	1.00	1.00	1.00	1.00	1.00
Uniform Delay (d), s/veh	26.9	0.0	0.0	24.6	0.0	20.9	11.4	12.0	12.1	12.4	6.2	6.3
Incr Delay (d2), s/veh	0.4	0.0	0.0	0.1	0.0	0.1	0.4	0.8	1.1	0.1	0.7	0.9
Initial Q Delay(d3), s/veh	0.0	0.0	0.0	0.0	0.0	0.0	0.0	0.0	0.0	0.0	0.0	0.0
%ile BackOfQ(95%),veh/ln	7.3	0.0	0.0	3.4	0.0	1.5	0.8	3.9	3.4	2.1	3.3	2.9
Unsig. Movement Delay, s/veh												
LnGrp Delay(d), s/veh	27.3	0.0	0.0	24.8	0.0	20.9	11.8	12.8	13.1	12.4	7.0	7.2
LnGrp LOS	C			C		C	B	B	B	B	A	A
Approach Vol, veh/h		215			163			423			634	
Approach Delay, s/veh		27.3			23.5			12.8			8.0	
Approach LOS		C			C			B			A	
Timer - Assigned Phs		2		4	5	6		8				
Phs Duration (G+Y+Rc), s		62.1		37.9	10.9	51.2		37.9				
Change Period (Y+Rc), s		6.0		6.0	6.0	6.0		6.0				
Max Green Setting (Gmax), s		55.0		33.0	5.0	44.0		33.0				
Max Q Clear Time (g_c+I1), s		7.4		6.3	5.1	7.9		13.3				
Green Ext Time (p_c), s		1.1		0.6	0.0	0.9		1.0				
Intersection Summary												
HCM 7th Control Delay, s/veh				14.1								
HCM 7th LOS				B								

104: Collins Ave & 16 Street

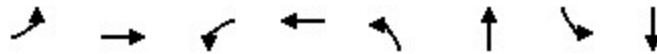

Lane Group	EBL	EBT	WBL	WBT	NBL	NBT	SBL	SBT
Lane Configurations								
Traffic Volume (vph)	62	3	2	6	29	310	13	395
Future Volume (vph)	62	3	2	6	29	310	13	395
Turn Type	Perm	NA	Perm	NA	Perm	NA	Perm	NA
Protected Phases		8		4		6		2
Permitted Phases	8		4		6		2	
Detector Phase	8	8	4	4	6	6	2	2
Switch Phase								
Minimum Initial (s)	7.0	7.0	7.0	7.0	5.0	5.0	5.0	5.0
Minimum Split (s)	26.2	26.2	26.2	26.2	34.2	34.2	34.2	34.2
Total Split (s)	30.0	30.0	30.0	30.0	70.0	70.0	70.0	70.0
Total Split (%)	30.0%	30.0%	30.0%	30.0%	70.0%	70.0%	70.0%	70.0%
Maximum Green (s)	24.0	24.0	24.0	24.0	63.8	63.8	63.8	63.8
Yellow Time (s)	4.0	4.0	4.0	4.0	4.0	4.0	4.0	4.0
All-Red Time (s)	2.0	2.0	2.0	2.0	2.2	2.2	2.2	2.2
Lost Time Adjust (s)	0.0	0.0	0.0	0.0		0.0		0.0
Total Lost Time (s)	6.0	6.0	6.0	6.0		6.2		6.2
Lead/Lag								
Lead-Lag Optimize?								
Vehicle Extension (s)	2.5	2.5	2.5	2.5	1.0	1.0	1.0	1.0
Recall Mode	None	None	None	None	C-Max	C-Max	C-Max	C-Max
Walk Time (s)	7.0	7.0	7.0	7.0	7.0	7.0	7.0	7.0
Flash Don't Walk (s)	13.0	13.0	13.0	13.0	21.0	21.0	21.0	21.0
Pedestrian Calls (#/hr)	100	100	100	100	100	100	100	100

Intersection Summary

Cycle Length: 100
 Actuated Cycle Length: 100
 Offset: 74 (74%), Referenced to phase 2:SBTL and 6:NBTL, Start of Yellow
 Natural Cycle: 65
 Control Type: Actuated-Coordinated

Splits and Phases: 104: Collins Ave & 16 Street



Queues

07/11/2025

104: Collins Ave & 16 Street



Lane Group	EBL	EBT	WBL	WBT	NBT	SBT
Lane Group Flow (vph)	64	139	2	15	356	539
v/c Ratio	0.39	0.44	0.01	0.07	0.18	0.28
Control Delay (s/veh)	42.2	11.1	32.5	22.4	5.8	5.5
Queue Delay	0.0	0.0	0.0	0.0	0.0	0.0
Total Delay (s/veh)	42.2	11.1	32.5	22.4	5.8	5.5
Queue Length 50th (ft)	35	2	1	3	38	54
Queue Length 95th (ft)	77	53	7	21	56	77
Internal Link Dist (ft)		784		333	896	387
Turn Bay Length (ft)	70					
Base Capacity (vph)	228	387	215	302	1927	1922
Starvation Cap Reductn	0	0	0	0	0	0
Spillback Cap Reductn	0	0	0	0	0	0
Storage Cap Reductn	0	0	0	0	0	0
Reduced v/c Ratio	0.28	0.36	0.01	0.05	0.18	0.28

Intersection Summary

HCM 7th Signalized Intersection Summary
 104: Collins Ave & 16 Street

07/11/2025



Movement	EBL	EBT	EBR	WBL	WBT	WBR	NBL	NBT	NBR	SBL	SBT	SBR
Lane Configurations	↖	↗		↖	↗			↕			↕	
Traffic Volume (veh/h)	62	3	132	2	6	9	29	310	6	13	395	115
Future Volume (veh/h)	62	3	132	2	6	9	29	310	6	13	395	115
Initial Q (Qb), veh	0	0	0	0	0	0	0	0	0	0	0	0
Lane Width Adj.	1.00	1.00	1.00	1.00	1.00	1.00	1.00	1.00	1.00	1.00	1.00	1.00
Ped-Bike Adj(A_pbT)	0.85		0.84	0.91		0.85	0.95		0.87	0.94		0.88
Parking Bus, Adj	1.00	1.00	0.90	1.00	1.00	0.90	1.00	1.00	0.90	1.00	1.00	0.90
Work Zone On Approach		No			No			No			No	
Adj Sat Flow, veh/h/ln	1670	1670	1670	1670	1670	1670	1670	1670	1670	1670	1670	1670
Adj Flow Rate, veh/h	64	3	136	2	6	9	30	320	6	13	407	119
Peak Hour Factor	0.97	0.97	0.97	0.97	0.97	0.97	0.97	0.97	0.97	0.97	0.97	0.97
Percent Heavy Veh, %	3	3	3	3	3	3	3	3	3	3	3	3
Cap, veh/h	271	5	207	151	96	144	169	1739	33	60	1470	415
Arrive On Green	0.20	0.20	0.20	0.20	0.20	0.20	0.91	0.91	0.91	0.91	0.91	0.91
Sat Flow, veh/h	1067	23	1051	1018	487	730	188	2553	48	32	2158	609
Grp Volume(v), veh/h	64	0	139	2	0	15	189	0	167	313	0	226
Grp Sat Flow(s),veh/h/ln	1067	0	1074	1018	0	1217	1438	0	1351	1641	0	1158
Q Serve(g_s), s	5.2	0.0	11.9	0.2	0.0	1.0	0.0	0.0	1.4	0.0	0.0	2.5
Cycle Q Clear(g_c), s	6.2	0.0	11.9	12.1	0.0	1.0	1.3	0.0	1.4	2.3	0.0	2.5
Prop In Lane	1.00		0.98	1.00		0.60	0.16		0.04	0.04		0.53
Lane Grp Cap(c), veh/h	271	0	211	151	0	239	1022	0	920	1155	0	789
V/C Ratio(X)	0.24	0.00	0.66	0.01	0.00	0.06	0.18	0.00	0.18	0.27	0.00	0.29
Avail Cap(c_a), veh/h	317	0	258	195	0	292	1022	0	920	1155	0	789
HCM Platoon Ratio	1.00	1.00	1.00	1.00	1.00	1.00	1.33	1.33	1.33	1.33	1.33	1.33
Upstream Filter(I)	1.00	0.00	1.00	1.00	0.00	1.00	1.00	0.00	1.00	1.00	0.00	1.00
Uniform Delay (d), s/veh	35.2	0.0	37.1	42.6	0.0	32.7	1.6	0.0	1.6	1.6	0.0	1.6
Incr Delay (d2), s/veh	0.3	0.0	3.6	0.0	0.0	0.1	0.4	0.0	0.4	0.6	0.0	0.9
Initial Q Delay(d3), s/veh	0.0	0.0	0.0	0.0	0.0	0.0	0.0	0.0	0.0	0.0	0.0	0.0
%ile BackOfQ(95%),veh/ln	2.5	0.0	6.0	0.1	0.0	0.5	0.8	0.0	0.7	1.4	0.0	1.1
Unsig. Movement Delay, s/veh												
LnGrp Delay(d), s/veh	35.5	0.0	40.7	42.7	0.0	32.7	2.0	0.0	2.0	2.2	0.0	2.5
LnGrp LOS	D		D	D		C	A		A	A		A
Approach Vol, veh/h		203			17			356				539
Approach Delay, s/veh		39.0			33.9			2.0				2.3
Approach LOS		D			C			A				A
Timer - Assigned Phs		2		4		6		8				
Phs Duration (G+Y+Rc), s		74.3		25.7		74.3		25.7				
Change Period (Y+Rc), s		6.2		6.0		6.2		6.0				
Max Green Setting (Gmax), s		63.8		24.0		63.8		24.0				
Max Q Clear Time (g_c+I1), s		4.5		14.1		3.4		13.9				
Green Ext Time (p_c), s		1.3		0.0		0.8		0.7				
Intersection Summary												
HCM 7th Control Delay, s/veh			9.4									
HCM 7th LOS			A									

Timings
101: Drexel Avenue & 16 Street

07/12/2025

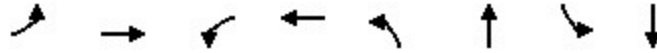

Lane Group	EBL	EBT	WBL	WBT	NBL	NBT	SBL	SBT
Lane Configurations		↕		↕		↕		↕
Traffic Volume (vph)	30	153	19	254	20	7	8	2
Future Volume (vph)	30	153	19	254	20	7	8	2
Turn Type	Perm	NA	Perm	NA	Perm	NA	Perm	NA
Protected Phases		6		2		4		8
Permitted Phases	6		2		4		8	
Detector Phase	6	6	2	2	4	4	8	8
Switch Phase								
Minimum Initial (s)	16.0	16.0	16.0	16.0	7.0	7.0	7.0	7.0
Minimum Split (s)	46.0	46.0	46.0	46.0	28.0	28.0	28.0	28.0
Total Split (s)	46.0	46.0	46.0	46.0	28.0	28.0	28.0	28.0
Total Split (%)	62.2%	62.2%	62.2%	62.2%	37.8%	37.8%	37.8%	37.8%
Maximum Green (s)	40.0	40.0	40.0	40.0	22.0	22.0	22.0	22.0
Yellow Time (s)	4.0	4.0	4.0	4.0	4.0	4.0	4.0	4.0
All-Red Time (s)	2.0	2.0	2.0	2.0	2.0	2.0	2.0	2.0
Lost Time Adjust (s)		0.0		0.0		0.0		0.0
Total Lost Time (s)		6.0		6.0		6.0		6.0
Lead/Lag								
Lead-Lag Optimize?								
Vehicle Extension (s)	1.0	1.0	1.0	1.0	2.5	2.5	2.5	2.5
Recall Mode	Max	Max	Max	Max	None	None	None	None
Walk Time (s)	5.0	5.0	5.0	5.0	5.0	5.0	5.0	5.0
Flash Don't Walk (s)	21.0	21.0	21.0	21.0	21.0	21.0	21.0	21.0
Pedestrian Calls (#/hr)	85	85	85	85	74	74	74	74

Intersection Summary

Cycle Length: 74
 Actuated Cycle Length: 82.6
 Natural Cycle: 75
 Control Type: Actuated-Uncoordinated

Splits and Phases: 101: Drexel Avenue & 16 Street

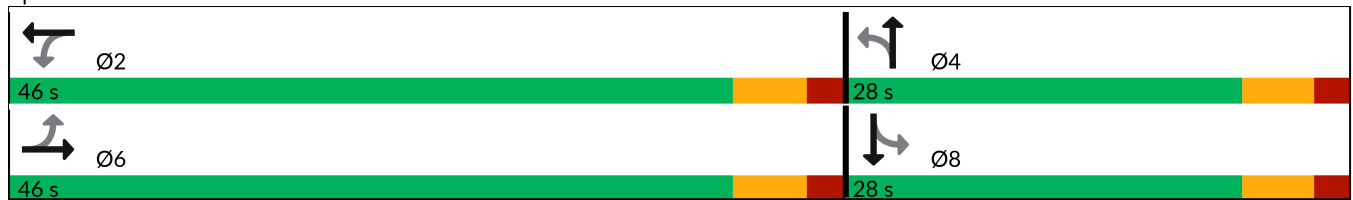

101: Drexel Avenue & 16 Street

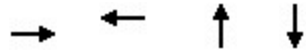

Lane Group	EBT	WBT	NBT	SBT
Lane Group Flow (vph)	223	345	39	29
v/c Ratio	0.23	0.34	0.11	0.08
Control Delay (s/veh)	9.6	10.6	18.3	12.6
Queue Delay	0.0	0.0	0.0	0.0
Total Delay (s/veh)	9.6	10.6	18.3	12.6
Queue Length 50th (ft)	54	92	13	5
Queue Length 95th (ft)	97	154	31	21
Internal Link Dist (ft)	176	70	207	304
Turn Bay Length (ft)				
Base Capacity (vph)	976	1027	410	420
Starvation Cap Reductn	0	0	0	0
Spillback Cap Reductn	0	0	0	0
Storage Cap Reductn	0	0	0	0
Reduced v/c Ratio	0.23	0.34	0.10	0.07

Intersection Summary

HCM 7th Signalized Intersection Summary
 101: Drexel Avenue & 16 Street

07/12/2025



Movement	EBL	EBT	EBR	WBL	WBT	WBR	NBL	NBT	NBR	SBL	SBT	SBR
Lane Configurations		↕			↕			↕			↕	
Traffic Volume (veh/h)	30	153	24	19	254	48	20	7	8	8	2	17
Future Volume (veh/h)	30	153	24	19	254	48	20	7	8	8	2	17
Initial Q (Qb), veh	0	0	0	0	0	0	0	0	0	0	0	0
Lane Width Adj.	1.00	1.00	1.00	1.00	1.00	1.00	1.00	1.00	1.00	1.00	1.00	1.00
Ped-Bike Adj(A_pbT)	0.97		0.93	0.96		0.93	0.90		0.87	0.90		0.89
Parking Bus, Adj	1.00	1.00	0.90	1.00	1.00	0.90	1.00	1.00	0.90	1.00	1.00	0.90
Work Zone On Approach		No			No			No			No	
Adj Sat Flow, veh/h/ln	1856	1856	1856	1856	1856	1856	1856	1856	1856	1856	1856	1856
Adj Flow Rate, veh/h	32	165	26	20	273	52	22	8	9	9	2	18
Peak Hour Factor	0.93	0.93	0.93	0.93	0.93	0.93	0.93	0.93	0.93	0.93	0.93	0.93
Percent Heavy Veh, %	3	3	3	3	3	3	3	3	3	3	3	3
Cap, veh/h	149	694	103	79	770	141	228	80	67	135	47	184
Arrive On Green	0.79	0.79	0.79	0.79	0.79	0.79	0.23	0.23	0.23	0.23	0.23	0.23
Sat Flow, veh/h	149	1176	175	39	1304	238	622	342	289	280	203	789
Grp Volume(v), veh/h	223	0	0	345	0	0	39	0	0	29	0	0
Grp Sat Flow(s),veh/h/ln	1500	0	0	1581	0	0	1254	0	0	1272	0	0
Q Serve(g_s), s	0.0	0.0	0.0	0.0	0.0	0.0	0.0	0.0	0.0	0.0	0.0	0.0
Cycle Q Clear(g_c), s	2.5	0.0	0.0	4.4	0.0	0.0	1.4	0.0	0.0	1.1	0.0	0.0
Prop In Lane	0.14		0.12	0.06		0.15	0.56		0.23	0.31		0.62
Lane Grp Cap(c), veh/h	946	0	0	990	0	0	375	0	0	365	0	0
V/C Ratio(X)	0.24	0.00	0.00	0.35	0.00	0.00	0.10	0.00	0.00	0.08	0.00	0.00
Avail Cap(c_a), veh/h	946	0	0	990	0	0	487	0	0	479	0	0
HCM Platoon Ratio	1.33	1.33	1.33	1.33	1.33	1.33	1.00	1.00	1.00	1.00	1.00	1.00
Upstream Filter(I)	1.00	0.00	0.00	1.00	0.00	0.00	1.00	0.00	0.00	1.00	0.00	0.00
Uniform Delay (d), s/veh	3.2	0.0	0.0	3.5	0.0	0.0	20.5	0.0	0.0	20.4	0.0	0.0
Incr Delay (d2), s/veh	0.6	0.0	0.0	1.0	0.0	0.0	0.1	0.0	0.0	0.1	0.0	0.0
Initial Q Delay(d3), s/veh	0.0	0.0	0.0	0.0	0.0	0.0	0.0	0.0	0.0	0.0	0.0	0.0
%ile BackOfQ(95%),veh/ln	1.4	0.0	0.0	2.3	0.0	0.0	0.8	0.0	0.0	0.6	0.0	0.0
Unsig. Movement Delay, s/veh												
LnGrp Delay(d), s/veh	3.8	0.0	0.0	4.4	0.0	0.0	20.6	0.0	0.0	20.4	0.0	0.0
LnGrp LOS	A			A			C			C		
Approach Vol, veh/h		223			345			39				29
Approach Delay, s/veh		3.8			4.4			20.6				20.4
Approach LOS		A			A			C				C
Timer - Assigned Phs		2		4		6		8				
Phs Duration (G+Y+Rc), s		46.0		21.8		46.0		21.8				
Change Period (Y+Rc), s		6.0		6.0		6.0		6.0				
Max Green Setting (Gmax), s		40.0		22.0		40.0		22.0				
Max Q Clear Time (g_c+I1), s		6.4		3.4		4.5		3.1				
Green Ext Time (p_c), s		0.8		0.1		0.5		0.1				

Intersection Summary		
HCM 7th Control Delay, s/veh		5.9
HCM 7th LOS		A

Notes
 User approved pedestrian interval to be less than phase max green.

Intersection						
Int Delay, s/veh	1.4					
Movement	EBL	EBT	WBT	WBR	SBL	SBR
Lane Configurations		↶	↷		↶	↷
Traffic Vol, veh/h	13	158	280	16	20	39
Future Vol, veh/h	13	158	280	16	20	39
Conflicting Peds, #/hr	84	0	0	84	4	4
Sign Control	Free	Free	Free	Free	Stop	Stop
RT Channelized	-	None	-	None	-	None
Storage Length	-	-	-	-	0	0
Veh in Median Storage, #	-	0	0	-	0	-
Grade, %	-	0	0	-	0	-
Peak Hour Factor	92	92	92	92	92	92
Heavy Vehicles, %	3	3	3	3	3	3
Mvmt Flow	14	172	304	17	22	42

Major/Minor	Major1	Major2	Minor2		
Conflicting Flow All	406	0	-	0	601
Stage 1	-	-	-	-	397
Stage 2	-	-	-	-	204
Critical Hdwy	4.13	-	-	-	5
Critical Hdwy Stg 1	-	-	-	-	5
Critical Hdwy Stg 2	-	-	-	-	5
Follow-up Hdwy	2.227	-	-	-	3
Pot Cap-1 Maneuver	1148	-	-	-	662
Stage 1	-	-	-	-	812
Stage 2	-	-	-	-	983
Platoon blocked, %		-	-	-	
Mov Cap-1 Maneuver	1067	-	-	-	564
Mov Cap-2 Maneuver	-	-	-	-	564
Stage 1	-	-	-	-	744
Stage 2	-	-	-	-	914

Approach	EB	WB	SB
HCM Control Delay, s/v	0.64	0	10.42
HCM LOS			B

Minor Lane/Major Mvmt	EBL	EBT	WBT	WBR	SBLn1	SBLn2
Capacity (veh/h)	137	-	-	-	564	793
HCM Lane V/C Ratio	0.013	-	-	-	0.039	0.053
HCM Control Delay (s/veh)	8.4	0	-	-	11.6	9.8
HCM Lane LOS	A	A	-	-	B	A
HCM 95th %tile Q(veh)	0	-	-	-	0.1	0.2

103: Washington Avenue & 16 Street



Lane Group	EBL	EBT	WBL	WBT	WBR	NBL	NBT	SBL	SBT
Lane Configurations		↔		↕	↗	↖	↕↔	↖	↕↔
Traffic Volume (vph)	39	91	53	111	114	48	582	67	590
Future Volume (vph)	39	91	53	111	114	48	582	67	590
Turn Type	Perm	NA	Perm	NA	pm+ov	Perm	NA	pm+pt	NA
Protected Phases		8		4	5		6	5	2
Permitted Phases	8		4		4	6		2	
Detector Phase	8	8	4	4	5	6	6	5	2
Switch Phase									
Minimum Initial (s)	7.0	7.0	7.0	7.0	5.0	7.0	7.0	5.0	7.0
Minimum Split (s)	39.0	39.0	39.0	39.0	11.0	27.0	27.0	11.0	27.0
Total Split (s)	39.0	39.0	39.0	39.0	11.0	70.0	70.0	11.0	81.0
Total Split (%)	32.5%	32.5%	32.5%	32.5%	9.2%	58.3%	58.3%	9.2%	67.5%
Maximum Green (s)	33.0	33.0	33.0	33.0	5.0	64.0	64.0	5.0	75.0
Yellow Time (s)	4.0	4.0	4.0	4.0	4.0	4.0	4.0	4.0	4.0
All-Red Time (s)	2.0	2.0	2.0	2.0	2.0	2.0	2.0	2.0	2.0
Lost Time Adjust (s)		0.0		0.0	0.0	0.0	0.0	0.0	0.0
Total Lost Time (s)		6.0		6.0	6.0	6.0	6.0	6.0	6.0
Lead/Lag					Lead	Lag	Lag	Lead	
Lead-Lag Optimize?					Yes	Yes	Yes	Yes	
Vehicle Extension (s)	2.5	2.5	2.5	2.5	2.0	1.0	1.0	2.0	1.0
Recall Mode	None	None	None	None	None	C-Max	C-Max	None	C-Max
Walk Time (s)	5.0	5.0	5.0	5.0		7.0	7.0		7.0
Flash Don't Walk (s)	28.0	28.0	28.0	28.0		14.0	14.0		14.0
Pedestrian Calls (#/hr)	100	100	100	100		100	100		100

Intersection Summary

Cycle Length: 120
 Actuated Cycle Length: 120
 Offset: 33 (28%), Referenced to phase 2:SBTL and 6:NBTL, Start of Yellow
 Natural Cycle: 80
 Control Type: Actuated-Coordinated

Splits and Phases: 103: Washington Avenue & 16 Street

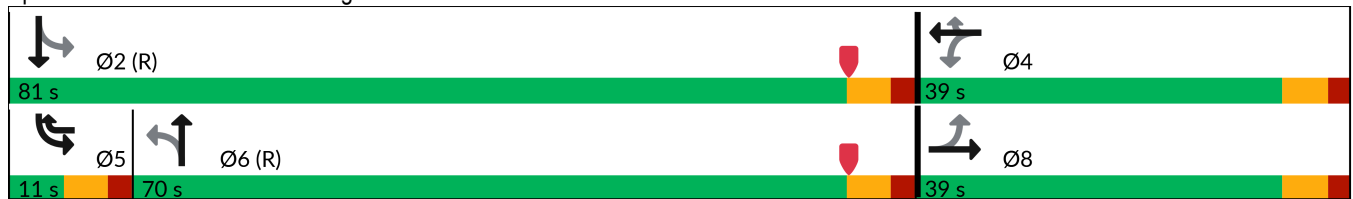

103: Washington Avenue & 16 Street



Lane Group	EBT	WBT	WBR	NBL	NBT	SBL	SBT
Lane Group Flow (vph)	180	167	116	49	648	68	754
v/c Ratio	0.47	0.45	0.26	0.20	0.39	0.20	0.43
Control Delay (s/veh)	37.8	40.5	11.4	17.3	17.0	10.3	11.5
Queue Delay	0.0	0.0	0.0	0.0	0.0	0.0	0.0
Total Delay (s/veh)	37.8	40.5	11.4	17.3	17.0	10.3	11.5
Queue Length 50th (ft)	106	107	18	19	146	19	136
Queue Length 95th (ft)	179	176	59	45	189	38	177
Internal Link Dist (ft)	170	490			200		499
Turn Bay Length (ft)				120		100	
Base Capacity (vph)	385	374	444	248	1679	338	1763
Starvation Cap Reductn	0	0	0	0	0	0	0
Spillback Cap Reductn	0	0	0	0	0	0	0
Storage Cap Reductn	0	0	0	0	0	0	0
Reduced v/c Ratio	0.47	0.45	0.26	0.20	0.39	0.20	0.43

Intersection Summary

HCM 7th Signalized Intersection Summary
 103: Washington Avenue & 16 Street

07/12/2025

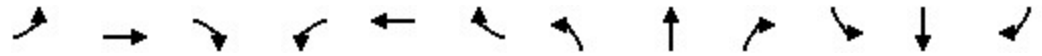

Movement	EBL	EBT	EBR	WBL	WBT	WBR	NBL	NBT	NBR	SBL	SBT	SBR
Lane Configurations		↔			↕	↗	↖	↕	↔	↖	↕	
Traffic Volume (veh/h)	39	91	46	53	111	114	48	582	53	67	590	149
Future Volume (veh/h)	39	91	46	53	111	114	48	582	53	67	590	149
Initial Q (Qb), veh	0	0	0	0	0	0	0	0	0	0	0	0
Lane Width Adj.	1.00	1.00	1.00	1.00	1.00	1.00	1.00	1.00	1.00	1.00	1.00	1.00
Ped-Bike Adj(A_pbT)	0.92		0.85	0.92		0.85	0.92		0.76	0.96		0.79
Parking Bus, Adj	1.00	1.00	0.90	1.00	1.00	0.90	1.00	1.00	0.90	1.00	1.00	0.90
Work Zone On Approach		No			No			No			No	
Adj Sat Flow, veh/h/ln	1856	1856	1856	1856	1856	1856	1856	1856	1856	1856	1856	1856
Adj Flow Rate, veh/h	40	93	47	54	113	116	49	594	54	68	602	152
Peak Hour Factor	0.98	0.98	0.98	0.98	0.98	0.98	0.98	0.98	0.98	0.98	0.98	0.98
Percent Heavy Veh, %	3	3	3	3	3	3	3	3	3	3	3	3
Cap, veh/h	87	181	82	141	277	382	411	1624	147	473	1565	393
Arrive On Green	0.27	0.27	0.27	0.27	0.27	0.27	0.72	0.72	0.72	0.05	0.83	0.83
Sat Flow, veh/h	183	661	298	372	1014	1205	651	3012	272	1767	2498	627
Grp Volume(v), veh/h	180	0	0	167	0	116	49	346	302	68	424	330
Grp Sat Flow(s),veh/h/ln	1143	0	0	1386	0	1205	651	1763	1522	1767	1763	1362
Q Serve(g_s), s	6.6	0.0	0.0	0.0	0.0	8.8	2.8	9.0	9.1	2.0	7.1	7.2
Cycle Q Clear(g_c), s	18.8	0.0	0.0	12.2	0.0	8.8	2.8	9.0	9.1	2.0	7.1	7.2
Prop In Lane	0.22		0.26	0.32		1.00	1.00		0.18	1.00		0.46
Lane Grp Cap(c), veh/h	349	0	0	419	0	382	411	950	821	473	1104	853
V/C Ratio(X)	0.52	0.00	0.00	0.40	0.00	0.30	0.12	0.36	0.37	0.14	0.38	0.39
Avail Cap(c_a), veh/h	351	0	0	421	0	384	411	950	821	481	1104	853
HCM Platoon Ratio	1.00	1.00	1.00	1.00	1.00	1.00	1.33	1.33	1.33	1.33	1.33	1.33
Upstream Filter(I)	1.00	0.00	0.00	1.00	0.00	1.00	1.00	1.00	1.00	1.00	1.00	1.00
Uniform Delay (d), s/veh	38.1	0.0	0.0	35.5	0.0	31.5	8.2	9.1	9.1	10.8	4.3	4.3
Incr Delay (d2), s/veh	1.0	0.0	0.0	0.5	0.0	0.3	0.6	1.1	1.3	0.1	1.0	1.3
Initial Q Delay(d3), s/veh	0.0	0.0	0.0	0.0	0.0	0.0	0.0	0.0	0.0	0.0	0.0	0.0
%ile BackOfQ(95%),veh/ln	8.4	0.0	0.0	7.4	0.0	4.7	0.8	5.8	5.2	1.3	4.1	3.3
Unsig. Movement Delay, s/veh												
LnGrp Delay(d), s/veh	39.0	0.0	0.0	35.9	0.0	31.9	8.8	10.2	10.4	10.8	5.3	5.7
LnGrp LOS	D			D		C	A	B	B	B	A	A
Approach Vol, veh/h		180			283			697			822	
Approach Delay, s/veh		39.0			34.3			10.2			5.9	
Approach LOS		D			C			B			A	
Timer - Assigned Phs		2		4	5	6		8				
Phs Duration (G+Y+Rc), s		81.2		38.8	10.5	70.7		38.8				
Change Period (Y+Rc), s		6.0		6.0	6.0	6.0		6.0				
Max Green Setting (Gmax), s		75.0		33.0	5.0	64.0		33.0				
Max Q Clear Time (g_c+I1), s		9.2		14.2	4.0	11.1		20.8				
Green Ext Time (p_c), s		1.8		1.1	0.0	1.6		0.7				
Intersection Summary												
HCM 7th Control Delay, s/veh				14.5								
HCM 7th LOS				B								

104: Collins Ave & 16 Street

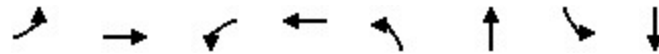

Lane Group	EBL	EBT	WBL	WBT	NBL	NBT	SBL	SBT
Lane Configurations								
Traffic Volume (vph)	127	9	7	6	64	436	18	502
Future Volume (vph)	127	9	7	6	64	436	18	502
Turn Type	Perm	NA	Perm	NA	Perm	NA	Perm	NA
Protected Phases		8		4		6		2
Permitted Phases	8		4		6		2	
Detector Phase	8	8	4	4	6	6	2	2
Switch Phase								
Minimum Initial (s)	7.0	7.0	7.0	7.0	5.0	5.0	5.0	5.0
Minimum Split (s)	26.2	26.2	26.2	26.2	34.2	34.2	34.2	34.2
Total Split (s)	30.0	30.0	30.0	30.0	70.0	70.0	70.0	70.0
Total Split (%)	30.0%	30.0%	30.0%	30.0%	70.0%	70.0%	70.0%	70.0%
Maximum Green (s)	24.0	24.0	24.0	24.0	63.8	63.8	63.8	63.8
Yellow Time (s)	4.0	4.0	4.0	4.0	4.0	4.0	4.0	4.0
All-Red Time (s)	2.0	2.0	2.0	2.0	2.2	2.2	2.2	2.2
Lost Time Adjust (s)	0.0	0.0	0.0	0.0		0.0		0.0
Total Lost Time (s)	6.0	6.0	6.0	6.0		6.2		6.2
Lead/Lag								
Lead-Lag Optimize?								
Vehicle Extension (s)	2.5	2.5	2.5	2.5	1.0	1.0	1.0	1.0
Recall Mode	None	None	None	None	C-Max	C-Max	C-Max	C-Max
Walk Time (s)	7.0	7.0	7.0	7.0	7.0	7.0	7.0	7.0
Flash Don't Walk (s)	13.0	13.0	13.0	13.0	21.0	21.0	21.0	21.0
Pedestrian Calls (#/hr)	100	100	100	100	100	100	100	100

Intersection Summary

Cycle Length: 100
 Actuated Cycle Length: 100
 Offset: 65 (65%), Referenced to phase 2:SBTL and 6:NBTL, Start of Yellow
 Natural Cycle: 65
 Control Type: Actuated-Coordinated

Splits and Phases: 104: Collins Ave & 16 Street



Queues

07/12/2025

104: Collins Ave & 16 Street



Lane Group	EBL	EBT	WBL	WBT	NBT	SBT
Lane Group Flow (vph)	130	77	7	18	520	662
v/c Ratio	0.74	0.29	0.04	0.08	0.31	0.38
Control Delay (s/veh)	61.3	12.6	30.7	19.1	7.5	7.3
Queue Delay	0.0	0.0	0.0	0.0	0.0	0.0
Total Delay (s/veh)	61.3	12.6	30.7	19.1	7.5	7.3
Queue Length 50th (ft)	78	5	4	3	63	75
Queue Length 95th (ft)	140	42	15	21	102	122
Internal Link Dist (ft)		784		333	896	387
Turn Bay Length (ft)	70					
Base Capacity (vph)	220	316	217	290	1659	1764
Starvation Cap Reductn	0	0	0	0	0	0
Spillback Cap Reductn	0	0	0	0	0	0
Storage Cap Reductn	0	0	0	0	0	0
Reduced v/c Ratio	0.59	0.24	0.03	0.06	0.31	0.38

Intersection Summary

HCM 7th Signalized Intersection Summary
 104: Collins Ave & 16 Street

07/12/2025

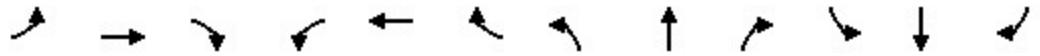

Movement	EBL	EBT	EBR	WBL	WBT	WBR	NBL	NBT	NBR	SBL	SBT	SBR
Lane Configurations	↖	↗		↖	↗			↕			↕	
Traffic Volume (veh/h)	127	9	67	7	6	12	64	436	10	18	502	129
Future Volume (veh/h)	127	9	67	7	6	12	64	436	10	18	502	129
Initial Q (Qb), veh	0	0	0	0	0	0	0	0	0	0	0	0
Lane Width Adj.	1.00	1.00	1.00	1.00	1.00	1.00	1.00	1.00	1.00	1.00	1.00	1.00
Ped-Bike Adj(A_pbT)	0.83		0.81	0.86		0.81	0.92		0.76	0.90		0.76
Parking Bus, Adj	1.00	1.00	0.90	1.00	1.00	0.90	1.00	1.00	0.90	1.00	1.00	0.90
Work Zone On Approach		No			No			No			No	
Adj Sat Flow, veh/h/ln	1670	1670	1670	1670	1670	1670	1670	1670	1670	1670	1670	1670
Adj Flow Rate, veh/h	130	9	68	7	6	12	65	445	10	18	512	132
Peak Hour Factor	0.98	0.98	0.98	0.98	0.98	0.98	0.98	0.98	0.98	0.98	0.98	0.98
Percent Heavy Veh, %	3	3	3	3	3	3	3	3	3	3	3	3
Cap, veh/h	263	25	187	210	76	152	232	1529	35	63	1449	362
Arrive On Green	0.20	0.20	0.20	0.20	0.20	0.20	0.90	0.90	0.90	0.90	0.90	0.90
Sat Flow, veh/h	1030	125	941	1017	383	766	275	2250	51	37	2133	533
Grp Volume(v), veh/h	130	0	77	7	0	18	258	0	262	395	0	267
Grp Sat Flow(s),veh/h/ln	1030	0	1066	1017	0	1149	1237	0	1340	1625	0	1078
Q Serve(g_s), s	11.8	0.0	6.2	0.6	0.0	1.3	0.0	0.0	2.5	0.0	0.0	3.6
Cycle Q Clear(g_c), s	13.0	0.0	6.2	6.8	0.0	1.3	1.9	0.0	2.5	3.3	0.0	3.6
Prop In Lane	1.00		0.88	1.00		0.67	0.25		0.04	0.05		0.49
Lane Grp Cap(c), veh/h	263	0	212	210	0	228	885	0	910	1142	0	732
V/C Ratio(X)	0.49	0.00	0.36	0.03	0.00	0.08	0.29	0.00	0.29	0.35	0.00	0.36
Avail Cap(c_a), veh/h	306	0	256	253	0	276	885	0	910	1142	0	732
HCM Platoon Ratio	1.00	1.00	1.00	1.00	1.00	1.00	1.33	1.33	1.33	1.33	1.33	1.33
Upstream Filter(I)	1.00	0.00	1.00	1.00	0.00	1.00	1.00	0.00	1.00	1.00	0.00	1.00
Uniform Delay (d), s/veh	37.9	0.0	34.6	37.6	0.0	32.6	1.6	0.0	1.7	1.7	0.0	1.7
Incr Delay (d2), s/veh	1.1	0.0	0.8	0.0	0.0	0.1	0.8	0.0	0.8	0.8	0.0	1.4
Initial Q Delay(d3), s/veh	0.0	0.0	0.0	0.0	0.0	0.0	0.0	0.0	0.0	0.0	0.0	0.0
%ile BackOfQ(95%),veh/ln	5.4	0.0	3.0	0.3	0.0	0.7	1.2	0.0	1.3	1.9	0.0	1.5
Unsig. Movement Delay, s/veh												
LnGrp Delay(d), s/veh	39.0	0.0	35.4	37.6	0.0	32.7	2.5	0.0	2.5	2.5	0.0	3.1
LnGrp LOS	D		D	D		C	A		A	A		A
Approach Vol, veh/h		207			25			520				662
Approach Delay, s/veh		37.7			34.1			2.5				2.8
Approach LOS		D			C			A				A
Timer - Assigned Phs		2		4		6		8				
Phs Duration (G+Y+Rc), s		74.1		25.9		74.1		25.9				
Change Period (Y+Rc), s		6.2		6.0		6.2		6.0				
Max Green Setting (Gmax), s		63.8		24.0		63.8		24.0				
Max Q Clear Time (g_c+I1), s		5.6		8.8		4.5		15.0				
Green Ext Time (p_c), s		1.7		0.0		1.4		0.5				
Intersection Summary												
HCM 7th Control Delay, s/veh			8.3									
HCM 7th LOS			A									

Timings
101: Drexel Avenue & 16 Street

07/12/2025



Lane Group	EBL	EBT	WBL	WBT	NBL	NBT	SBL	SBT
Lane Configurations		↕		↕		↕		↕
Traffic Volume (vph)	57	183	20	262	21	7	22	2
Future Volume (vph)	57	183	20	262	21	7	22	2
Turn Type	Perm	NA	Perm	NA	Perm	NA	Perm	NA
Protected Phases		6		2		4		8
Permitted Phases	6		2		4		8	
Detector Phase	6	6	2	2	4	4	8	8
Switch Phase								
Minimum Initial (s)	16.0	16.0	16.0	16.0	7.0	7.0	7.0	7.0
Minimum Split (s)	46.0	46.0	46.0	46.0	28.0	28.0	28.0	28.0
Total Split (s)	46.0	46.0	46.0	46.0	28.0	28.0	28.0	28.0
Total Split (%)	62.2%	62.2%	62.2%	62.2%	37.8%	37.8%	37.8%	37.8%
Maximum Green (s)	40.0	40.0	40.0	40.0	22.0	22.0	22.0	22.0
Yellow Time (s)	4.0	4.0	4.0	4.0	4.0	4.0	4.0	4.0
All-Red Time (s)	2.0	2.0	2.0	2.0	2.0	2.0	2.0	2.0
Lost Time Adjust (s)		0.0		0.0		0.0		0.0
Total Lost Time (s)		6.0		6.0		6.0		6.0
Lead/Lag								
Lead-Lag Optimize?								
Vehicle Extension (s)	1.0	1.0	1.0	1.0	2.5	2.5	2.5	2.5
Recall Mode	Max	Max	Max	Max	None	None	None	None
Walk Time (s)	5.0	5.0	5.0	5.0	5.0	5.0	5.0	5.0
Flash Don't Walk (s)	21.0	21.0	21.0	21.0	21.0	21.0	21.0	21.0
Pedestrian Calls (#/hr)	85	85	85	85	74	74	74	74

Intersection Summary

Cycle Length: 74
 Actuated Cycle Length: 79.8
 Natural Cycle: 75
 Control Type: Actuated-Uncoordinated

Splits and Phases: 101: Drexel Avenue & 16 Street

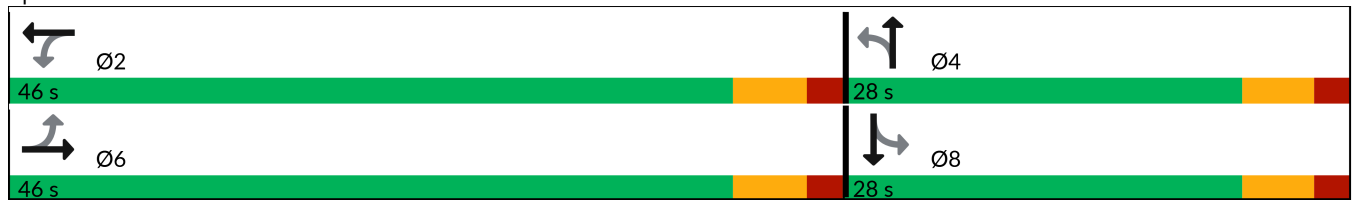

101: Drexel Avenue & 16 Street

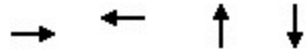

Lane Group	EBT	WBT	NBT	SBT
Lane Group Flow (vph)	284	379	40	70
v/c Ratio	0.32	0.38	0.11	0.19
Control Delay (s/veh)	11.2	11.4	17.0	10.9
Queue Delay	0.0	0.4	0.0	0.0
Total Delay (s/veh)	11.2	11.8	17.0	10.9
Queue Length 50th (ft)	76	103	12	10
Queue Length 95th (ft)	132	173	31	36
Internal Link Dist (ft)	176	70	207	304
Turn Bay Length (ft)				
Base Capacity (vph)	889	991	415	436
Starvation Cap Reductn	0	237	0	0
Spillback Cap Reductn	0	0	0	0
Storage Cap Reductn	0	0	0	0
Reduced v/c Ratio	0.32	0.50	0.10	0.16

Intersection Summary

HCM 7th Signalized Intersection Summary
 101: Drexel Avenue & 16 Street

07/12/2025

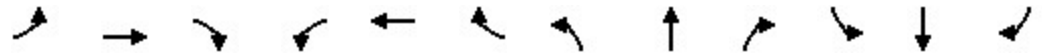

Movement	EBL	EBT	EBR	WBL	WBT	WBR	NBL	NBT	NBR	SBL	SBT	SBR
Lane Configurations		↕			↕			↕			↕	
Traffic Volume (veh/h)	57	183	24	20	262	70	21	7	8	22	2	41
Future Volume (veh/h)	57	183	24	20	262	70	21	7	8	22	2	41
Initial Q (Qb), veh	0	0	0	0	0	0	0	0	0	0	0	0
Lane Width Adj.	1.00	1.00	1.00	1.00	1.00	1.00	1.00	1.00	1.00	1.00	1.00	1.00
Ped-Bike Adj(A_pbT)	0.97		0.93	0.97		0.93	0.91		0.87	0.90		0.89
Parking Bus, Adj	1.00	1.00	0.90	1.00	1.00	0.90	1.00	1.00	0.90	1.00	1.00	0.90
Work Zone On Approach		No			No			No			No	
Adj Sat Flow, veh/h/ln	1856	1856	1856	1856	1856	1856	1856	1856	1856	1856	1856	1856
Adj Flow Rate, veh/h	61	197	26	22	282	75	23	8	9	24	2	44
Peak Hour Factor	0.93	0.93	0.93	0.93	0.93	0.93	0.93	0.93	0.93	0.93	0.93	0.93
Percent Heavy Veh, %	3	3	3	3	3	3	3	3	3	3	3	3
Cap, veh/h	206	616	76	79	711	181	237	79	68	147	34	187
Arrive On Green	0.78	0.78	0.78	0.78	0.78	0.78	0.24	0.24	0.24	0.24	0.24	0.24
Sat Flow, veh/h	242	1051	130	39	1212	309	648	334	285	322	145	789
Grp Volume(v), veh/h	284	0	0	379	0	0	40	0	0	70	0	0
Grp Sat Flow(s),veh/h/ln	1423	0	0	1560	0	0	1267	0	0	1255	0	0
Q Serve(g_s), s	0.0	0.0	0.0	0.0	0.0	0.0	0.0	0.0	0.0	0.0	0.0	0.0
Cycle Q Clear(g_c), s	3.4	0.0	0.0	5.3	0.0	0.0	1.4	0.0	0.0	2.8	0.0	0.0
Prop In Lane	0.21		0.09	0.06		0.20	0.57		0.22	0.34		0.63
Lane Grp Cap(c), veh/h	899	0	0	971	0	0	384	0	0	369	0	0
V/C Ratio(X)	0.32	0.00	0.00	0.39	0.00	0.00	0.10	0.00	0.00	0.19	0.00	0.00
Avail Cap(c_a), veh/h	899	0	0	971	0	0	487	0	0	473	0	0
HCM Platoon Ratio	1.33	1.33	1.33	1.33	1.33	1.33	1.00	1.00	1.00	1.00	1.00	1.00
Upstream Filter(I)	1.00	0.00	0.00	1.00	0.00	0.00	1.00	0.00	0.00	1.00	0.00	0.00
Uniform Delay (d), s/veh	3.5	0.0	0.0	3.7	0.0	0.0	20.4	0.0	0.0	20.9	0.0	0.0
Incr Delay (d2), s/veh	0.9	0.0	0.0	1.2	0.0	0.0	0.1	0.0	0.0	0.2	0.0	0.0
Initial Q Delay(d3), s/veh	0.0	0.0	0.0	0.0	0.0	0.0	0.0	0.0	0.0	0.0	0.0	0.0
%ile BackOfQ(95%),veh/ln	1.9	0.0	0.0	2.6	0.0	0.0	0.9	0.0	0.0	1.6	0.0	0.0
Unsig. Movement Delay, s/veh												
LnGrp Delay(d), s/veh	4.4	0.0	0.0	4.9	0.0	0.0	20.4	0.0	0.0	21.1	0.0	0.0
LnGrp LOS	A			A			C			C		
Approach Vol, veh/h		284			379			40				70
Approach Delay, s/veh		4.4			4.9			20.4				21.1
Approach LOS		A			A			C				C
Timer - Assigned Phs		2		4		6		8				
Phs Duration (G+Y+Rc), s		46.0		22.2		46.0		22.2				
Change Period (Y+Rc), s		6.0		6.0		6.0		6.0				
Max Green Setting (Gmax), s		40.0		22.0		40.0		22.0				
Max Q Clear Time (g_c+I1), s		7.3		3.4		5.4		4.8				
Green Ext Time (p_c), s		0.9		0.1		0.7		0.2				
Intersection Summary												
HCM 7th Control Delay, s/veh				7.0								
HCM 7th LOS				A								
Notes												
User approved pedestrian interval to be less than phase max green.												

Intersection						
Int Delay, s/veh	1.3					
Movement	EBL	EBT	WBT	WBR	SBL	SBR
Lane Configurations		↶	↷		↶	↷
Traffic Vol, veh/h	14	202	308	16	21	40
Future Vol, veh/h	14	202	308	16	21	40
Conflicting Peds, #/hr	84	0	0	84	4	4
Sign Control	Free	Free	Free	Free	Stop	Stop
RT Channelized	-	None	-	None	-	None
Storage Length	-	-	-	-	0	0
Veh in Median Storage, #	-	0	0	-	0	-
Grade, %	-	0	0	-	0	-
Peak Hour Factor	92	92	92	92	92	92
Heavy Vehicles, %	3	3	3	3	3	3
Mvmt Flow	15	220	335	17	23	43

Major/Minor	Major1	Major2	Minor2		
Conflicting Flow All	436	0	-	0	681 431
Stage 1	-	-	-	-	427 -
Stage 2	-	-	-	-	254 -
Critical Hdwy	4.13	-	-	-	5 4.5
Critical Hdwy Stg 1	-	-	-	-	5 -
Critical Hdwy Stg 2	-	-	-	-	5 -
Follow-up Hdwy	2.227	-	-	-	3 3
Pot Cap-1 Maneuver	1118	-	-	-	610 833
Stage 1	-	-	-	-	788 -
Stage 2	-	-	-	-	936 -
Platoon blocked, %		-	-	-	
Mov Cap-1 Maneuver	1040	-	-	-	519 772
Mov Cap-2 Maneuver	-	-	-	-	519 -
Stage 1	-	-	-	-	720 -
Stage 2	-	-	-	-	870 -

Approach	EB	WB	SB
HCM Control Delay, s/v	0.55	0	10.74
HCM LOS			B

Minor Lane/Major Mvmt	EBL	EBT	WBT	WBR	SBLn1	SBLn2
Capacity (veh/h)	117	-	-	-	519	772
HCM Lane V/C Ratio	0.015	-	-	-	0.044	0.056
HCM Control Delay (s/veh)	8.5	0	-	-	12.3	9.9
HCM Lane LOS	A	A	-	-	B	A
HCM 95th %tile Q(veh)	0	-	-	-	0.1	0.2

103: Washington Avenue & 16 Street



Lane Group	EBL	EBT	WBL	WBT	WBR	NBL	NBT	SBL	SBT
Lane Configurations		↕		↕	↕	↕	↕↔	↕	↕↔
Traffic Volume (vph)	40	132	102	145	134	50	583	144	576
Future Volume (vph)	40	132	102	145	134	50	583	144	576
Turn Type	Perm	NA	Perm	NA	pm+ov	Perm	NA	pm+pt	NA
Protected Phases		8		4	5		6	5	2
Permitted Phases	8		4		4	6		2	
Detector Phase	8	8	4	4	5	6	6	5	2
Switch Phase									
Minimum Initial (s)	7.0	7.0	7.0	7.0	5.0	7.0	7.0	5.0	7.0
Minimum Split (s)	39.0	39.0	39.0	39.0	11.0	27.0	27.0	11.0	27.0
Total Split (s)	39.0	39.0	39.0	39.0	11.0	70.0	70.0	11.0	81.0
Total Split (%)	32.5%	32.5%	32.5%	32.5%	9.2%	58.3%	58.3%	9.2%	67.5%
Maximum Green (s)	33.0	33.0	33.0	33.0	5.0	64.0	64.0	5.0	75.0
Yellow Time (s)	4.0	4.0	4.0	4.0	4.0	4.0	4.0	4.0	4.0
All-Red Time (s)	2.0	2.0	2.0	2.0	2.0	2.0	2.0	2.0	2.0
Lost Time Adjust (s)		0.0		0.0	0.0	0.0	0.0	0.0	0.0
Total Lost Time (s)		6.0		6.0	6.0	6.0	6.0	6.0	6.0
Lead/Lag					Lead	Lag	Lag	Lead	
Lead-Lag Optimize?					Yes	Yes	Yes	Yes	
Vehicle Extension (s)	2.5	2.5	2.5	2.5	2.0	1.0	1.0	2.0	1.0
Recall Mode	None	None	None	None	None	C-Max	C-Max	None	C-Max
Walk Time (s)	5.0	5.0	5.0	5.0		7.0	7.0		7.0
Flash Don't Walk (s)	28.0	28.0	28.0	28.0		14.0	14.0		14.0
Pedestrian Calls (#/hr)	100	100	100	100		100	100		100

Intersection Summary

Cycle Length: 120
 Actuated Cycle Length: 120
 Offset: 33 (28%), Referenced to phase 2:SBTL and 6:NBTL, Start of Yellow
 Natural Cycle: 80
 Control Type: Actuated-Coordinated

Splits and Phases: 103: Washington Avenue & 16 Street

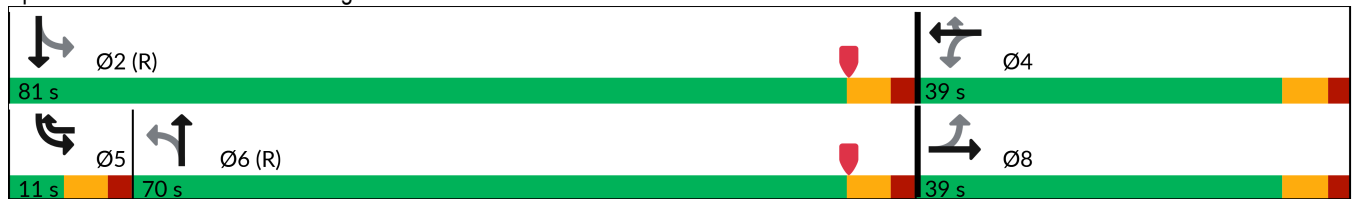

103: Washington Avenue & 16 Street



Lane Group	EBT	WBT	WBR	NBL	NBT	SBL	SBT
Lane Group Flow (vph)	224	252	137	51	762	147	738
v/c Ratio	0.62	0.83	0.31	0.20	0.50	0.48	0.42
Control Delay (s/veh)	44.9	64.7	13.9	17.4	17.9	15.2	11.4
Queue Delay	0.0	0.0	0.0	0.0	0.0	0.0	0.0
Total Delay (s/veh)	44.9	64.7	13.9	17.4	17.9	15.2	11.4
Queue Length 50th (ft)	145	184	29	20	177	44	132
Queue Length 95th (ft)	234	#330	75	46	231	73	172
Internal Link Dist (ft)	170	490			200		499
Turn Bay Length (ft)				120		100	
Base Capacity (vph)	360	303	444	250	1535	306	1761
Starvation Cap Reductn	0	0	0	0	0	0	0
Spillback Cap Reductn	0	0	0	0	0	0	0
Storage Cap Reductn	0	0	0	0	0	0	0
Reduced v/c Ratio	0.62	0.83	0.31	0.20	0.50	0.48	0.42

Intersection Summary

95th percentile volume exceeds capacity, queue may be longer.

Queue shown is maximum after two cycles.

HCM 7th Signalized Intersection Summary
 103: Washington Avenue & 16 Street

07/12/2025

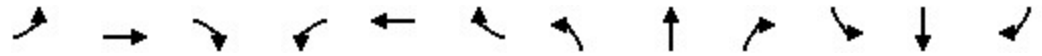

Movement	EBL	EBT	EBR	WBL	WBT	WBR	NBL	NBT	NBR	SBL	SBT	SBR
Lane Configurations		↔			↕	↗	↖	↕	↔	↖	↕	↗
Traffic Volume (veh/h)	40	132	47	102	145	134	50	583	164	144	576	147
Future Volume (veh/h)	40	132	47	102	145	134	50	583	164	144	576	147
Initial Q (Qb), veh	0	0	0	0	0	0	0	0	0	0	0	0
Lane Width Adj.	1.00	1.00	1.00	1.00	1.00	1.00	1.00	1.00	1.00	1.00	1.00	1.00
Ped-Bike Adj(A_pbT)	0.96		0.85	0.95		0.85	0.92		0.76	0.98		0.79
Parking Bus, Adj	1.00	1.00	0.90	1.00	1.00	0.90	1.00	1.00	0.90	1.00	1.00	0.90
Work Zone On Approach		No			No			No			No	
Adj Sat Flow, veh/h/ln	1856	1856	1856	1856	1856	1856	1856	1856	1856	1856	1856	1856
Adj Flow Rate, veh/h	41	135	48	104	148	137	51	595	167	147	588	150
Peak Hour Factor	0.98	0.98	0.98	0.98	0.98	0.98	0.98	0.98	0.98	0.98	0.98	0.98
Percent Heavy Veh, %	3	3	3	3	3	3	3	3	3	3	3	3
Cap, veh/h	35	87	24	120	139	391	411	1279	356	425	1557	394
Arrive On Green	0.28	0.28	0.28	0.28	0.28	0.28	0.71	0.71	0.71	0.06	0.83	0.83
Sat Flow, veh/h	0	316	86	283	507	1206	659	2398	668	1767	2492	631
Grp Volume(v), veh/h	224	0	0	252	0	137	51	436	326	147	415	323
Grp Sat Flow(s),veh/h/ln	402	0	0	790	0	1206	659	1763	1303	1767	1763	1360
Q Serve(g_s), s	0.0	0.0	0.0	0.0	0.0	10.5	3.0	12.9	13.1	4.5	6.9	7.0
Cycle Q Clear(g_c), s	33.0	0.0	0.0	33.0	0.0	10.5	3.0	12.9	13.1	4.5	6.9	7.0
Prop In Lane	0.18		0.21	0.41		1.00	1.00		0.51	1.00		0.46
Lane Grp Cap(c), veh/h	146	0	0	260	0	391	411	940	695	425	1102	850
V/C Ratio(X)	1.53	0.00	0.00	0.97	0.00	0.35	0.12	0.46	0.47	0.35	0.38	0.38
Avail Cap(c_a), veh/h	146	0	0	260	0	391	411	940	695	425	1102	850
HCM Platoon Ratio	1.00	1.00	1.00	1.00	1.00	1.00	1.33	1.33	1.33	1.33	1.33	1.33
Upstream Filter(I)	1.00	0.00	0.00	1.00	0.00	1.00	1.00	1.00	1.00	1.00	1.00	1.00
Uniform Delay (d), s/veh	38.3	0.0	0.0	44.7	0.0	31.6	8.6	10.0	10.0	12.0	4.4	4.4
Incr Delay (d2), s/veh	271.1	0.0	0.0	47.4	0.0	0.4	0.6	1.6	2.3	0.2	1.0	1.3
Initial Q Delay(d3), s/veh	0.0	0.0	0.0	0.0	0.0	0.0	0.0	0.0	0.0	0.0	0.0	0.0
%ile BackOfQ(95%),veh/ln	24.8	0.0	0.0	16.5	0.0	5.6	0.9	7.9	6.2	3.0	4.1	3.3
Unsig. Movement Delay, s/veh												
LnGrp Delay(d), s/veh	309.3	0.0	0.0	92.1	0.0	32.0	9.2	11.7	12.3	12.1	5.4	5.7
LnGrp LOS	F			F		C	A	B	B	B	A	A
Approach Vol, veh/h		224			389			813			885	
Approach Delay, s/veh		309.3			70.9			11.8			6.6	
Approach LOS		F			E			B			A	
Timer - Assigned Phs		2		4	5	6		8				
Phs Duration (G+Y+Rc), s		81.0		39.0	11.0	70.0		39.0				
Change Period (Y+Rc), s		6.0		6.0	6.0	6.0		6.0				
Max Green Setting (Gmax), s		75.0		33.0	5.0	64.0		33.0				
Max Q Clear Time (g_c+I1), s		9.0		35.0	6.5	15.1		35.0				
Green Ext Time (p_c), s		1.7		0.0	0.0	2.1		0.0				
Intersection Summary												
HCM 7th Control Delay, s/veh				48.6								
HCM 7th LOS				D								

Timings
104: Collins Ave & 16 Street

07/12/2025

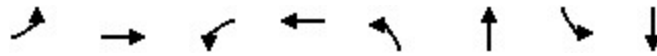

Lane Group	EBL	EBT	WBL	WBT	NBL	NBT	SBL	SBT
Lane Configurations	↘	↗	↘	↗		↕		↕
Traffic Volume (vph)	144	9	7	6	82	442	18	499
Future Volume (vph)	144	9	7	6	82	442	18	499
Turn Type	Perm	NA	Perm	NA	Perm	NA	Perm	NA
Protected Phases		8		4		6		2
Permitted Phases	8		4		6		2	
Detector Phase	8	8	4	4	6	6	2	2
Switch Phase								
Minimum Initial (s)	7.0	7.0	7.0	7.0	5.0	5.0	5.0	5.0
Minimum Split (s)	26.2	26.2	26.2	26.2	34.2	34.2	34.2	34.2
Total Split (s)	30.0	30.0	30.0	30.0	70.0	70.0	70.0	70.0
Total Split (%)	30.0%	30.0%	30.0%	30.0%	70.0%	70.0%	70.0%	70.0%
Maximum Green (s)	24.0	24.0	24.0	24.0	63.8	63.8	63.8	63.8
Yellow Time (s)	4.0	4.0	4.0	4.0	4.0	4.0	4.0	4.0
All-Red Time (s)	2.0	2.0	2.0	2.0	2.2	2.2	2.2	2.2
Lost Time Adjust (s)	0.0	0.0	0.0	0.0		0.0		0.0
Total Lost Time (s)	6.0	6.0	6.0	6.0		6.2		6.2
Lead/Lag								
Lead-Lag Optimize?								
Vehicle Extension (s)	2.5	2.5	2.5	2.5	1.0	1.0	1.0	1.0
Recall Mode	None	None	None	None	C-Max	C-Max	C-Max	C-Max
Walk Time (s)	7.0	7.0	7.0	7.0	7.0	7.0	7.0	7.0
Flash Don't Walk (s)	13.0	13.0	13.0	13.0	21.0	21.0	21.0	21.0
Pedestrian Calls (#/hr)	100	100	100	100	100	100	100	100

Intersection Summary

Cycle Length: 100
 Actuated Cycle Length: 100
 Offset: 65 (65%), Referenced to phase 2:SBTL and 6:NBTL, Start of Yellow
 Natural Cycle: 65
 Control Type: Actuated-Coordinated

Splits and Phases: 104: Collins Ave & 16 Street



Queues

07/12/2025

104: Collins Ave & 16 Street



Lane Group	EBL	EBT	WBL	WBT	NBT	SBT
Lane Group Flow (vph)	147	249	7	19	545	713
v/c Ratio	0.79	0.87	0.06	0.08	0.36	0.43
Control Delay (s/veh)	65.8	54.2	31.3	18.5	8.4	7.7
Queue Delay	0.0	0.0	0.0	0.0	0.0	0.0
Total Delay (s/veh)	65.8	54.2	31.3	18.5	8.4	7.7
Queue Length 50th (ft)	87	102	4	3	74	88
Queue Length 95th (ft)	#174	#229	16	22	111	131
Internal Link Dist (ft)		784		333	896	387
Turn Bay Length (ft)	70					
Base Capacity (vph)	219	321	131	289	1520	1671
Starvation Cap Reductn	0	0	0	0	0	0
Spillback Cap Reductn	0	0	0	0	0	0
Storage Cap Reductn	0	0	0	0	0	0
Reduced v/c Ratio	0.67	0.78	0.05	0.07	0.36	0.43

Intersection Summary

95th percentile volume exceeds capacity, queue may be longer.
 Queue shown is maximum after two cycles.

HCM 7th Signalized Intersection Summary
 104: Collins Ave & 16 Street

07/12/2025

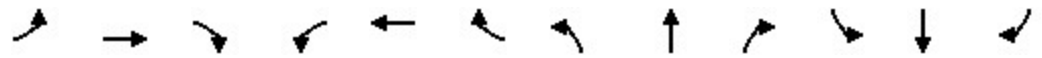

Movement	EBL	EBT	EBR	WBL	WBT	WBR	NBL	NBT	NBR	SBL	SBT	SBR
Lane Configurations	↖	↗		↖	↗			↕			↕	
Traffic Volume (veh/h)	144	9	235	7	6	13	82	442	10	18	499	182
Future Volume (veh/h)	144	9	235	7	6	13	82	442	10	18	499	182
Initial Q (Qb), veh	0	0	0	0	0	0	0	0	0	0	0	0
Lane Width Adj.	1.00	1.00	1.00	1.00	1.00	1.00	1.00	1.00	1.00	1.00	1.00	1.00
Ped-Bike Adj(A_pbT)	0.86		0.84	1.00		0.84	0.93		0.75	0.90		0.75
Parking Bus, Adj	1.00	1.00	0.90	1.00	1.00	0.90	1.00	1.00	0.90	1.00	1.00	0.90
Work Zone On Approach		No			No			No			No	
Adj Sat Flow, veh/h/ln	1670	1670	1670	1670	1670	1670	1670	1670	1670	1670	1670	1670
Adj Flow Rate, veh/h	147	9	240	7	6	13	84	451	10	18	509	186
Peak Hour Factor	0.98	0.98	0.98	0.98	0.98	0.98	0.98	0.98	0.98	0.98	0.98	0.98
Percent Heavy Veh, %	3	3	3	3	3	3	3	3	3	3	3	3
Cap, veh/h	315	9	249	84	89	193	249	1312	30	56	1219	431
Arrive On Green	0.24	0.24	0.24	0.24	0.24	0.24	0.85	0.85	0.85	0.85	0.85	0.85
Sat Flow, veh/h	1069	39	1038	1010	371	804	316	2056	47	30	1911	675
Grp Volume(v), veh/h	147	0	249	7	0	19	258	0	287	442	0	271
Grp Sat Flow(s),veh/h/ln	1069	0	1077	1010	0	1175	1078	0	1341	1633	0	981
Q Serve(g_s), s	12.3	0.0	22.8	0.7	0.0	1.2	1.1	0.0	4.5	0.0	0.0	6.6
Cycle Q Clear(g_c), s	13.6	0.0	22.8	23.5	0.0	1.2	7.7	0.0	4.5	6.2	0.0	6.6
Prop In Lane	1.00		0.96	1.00		0.68	0.33		0.03	0.04		0.69
Lane Grp Cap(c), veh/h	315	0	259	84	0	282	735	0	855	1080	0	626
V/C Ratio(X)	0.47	0.00	0.96	0.08	0.00	0.07	0.35	0.00	0.34	0.41	0.00	0.43
Avail Cap(c_a), veh/h	315	0	259	84	0	282	735	0	855	1080	0	626
HCM Platoon Ratio	1.00	1.00	1.00	1.00	1.00	1.00	1.33	1.33	1.33	1.33	1.33	1.33
Upstream Filter(I)	1.00	0.00	1.00	1.00	0.00	1.00	1.00	0.00	1.00	1.00	0.00	1.00
Uniform Delay (d), s/veh	34.6	0.0	37.6	49.2	0.0	29.4	3.0	0.0	3.1	3.2	0.0	3.2
Incr Delay (d2), s/veh	0.8	0.0	45.5	0.3	0.0	0.1	1.3	0.0	1.1	1.2	0.0	2.2
Initial Q Delay(d3), s/veh	0.0	0.0	0.0	0.0	0.0	0.0	0.0	0.0	0.0	0.0	0.0	0.0
%ile BackOfQ(95%),veh/ln	5.8	0.0	14.1	0.3	0.0	0.6	2.0	0.0	2.2	3.3	0.0	2.3
Unsig. Movement Delay, s/veh												
LnGrp Delay(d), s/veh	35.4	0.0	83.1	49.5	0.0	29.4	4.3	0.0	4.1	4.4	0.0	5.4
LnGrp LOS	D		F	D		C	A		A	A		A
Approach Vol, veh/h		396			26			545			713	
Approach Delay, s/veh		65.4			34.8			4.2			4.8	
Approach LOS		E			C			A			A	
Timer - Assigned Phs		2		4		6		8				
Phs Duration (G+Y+Rc), s		70.0		30.0		70.0		30.0				
Change Period (Y+Rc), s		6.2		6.0		6.2		6.0				
Max Green Setting (Gmax), s		63.8		24.0		63.8		24.0				
Max Q Clear Time (g_c+I1), s		8.6		25.5		9.7		24.8				
Green Ext Time (p_c), s		2.0		0.0		1.6		0.0				
Intersection Summary												
HCM 7th Control Delay, s/veh			19.3									
HCM 7th LOS			B									

Timings
101: Drexel Avenue & 16 Street

07/12/2025

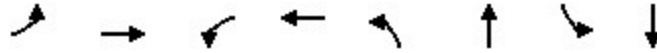

Lane Group	EBL	EBT	WBL	WBT	NBL	NBT	SBL	SBT
Lane Configurations		↕		↕		↕		↕
Traffic Volume (vph)	57	194	21	270	21	7	22	2
Future Volume (vph)	57	194	21	270	21	7	22	2
Turn Type	Perm	NA	Perm	NA	Perm	NA	Perm	NA
Protected Phases		6		2		4		8
Permitted Phases	6		2		4		8	
Detector Phase	6	6	2	2	4	4	8	8
Switch Phase								
Minimum Initial (s)	16.0	16.0	16.0	16.0	7.0	7.0	7.0	7.0
Minimum Split (s)	46.0	46.0	46.0	46.0	28.0	28.0	28.0	28.0
Total Split (s)	46.0	46.0	46.0	46.0	28.0	28.0	28.0	28.0
Total Split (%)	62.2%	62.2%	62.2%	62.2%	37.8%	37.8%	37.8%	37.8%
Maximum Green (s)	40.0	40.0	40.0	40.0	22.0	22.0	22.0	22.0
Yellow Time (s)	4.0	4.0	4.0	4.0	4.0	4.0	4.0	4.0
All-Red Time (s)	2.0	2.0	2.0	2.0	2.0	2.0	2.0	2.0
Lost Time Adjust (s)		0.0		0.0		0.0		0.0
Total Lost Time (s)		6.0		6.0		6.0		6.0
Lead/Lag								
Lead-Lag Optimize?								
Vehicle Extension (s)	1.0	1.0	1.0	1.0	2.5	2.5	2.5	2.5
Recall Mode	Max	Max	Max	Max	None	None	None	None
Walk Time (s)	5.0	5.0	5.0	5.0	5.0	5.0	5.0	5.0
Flash Don't Walk (s)	21.0	21.0	21.0	21.0	21.0	21.0	21.0	21.0
Pedestrian Calls (#/hr)	85	85	85	85	74	74	74	74

Intersection Summary

Cycle Length: 74
 Actuated Cycle Length: 79.7
 Natural Cycle: 75
 Control Type: Actuated-Uncoordinated

Splits and Phases: 101: Drexel Avenue & 16 Street

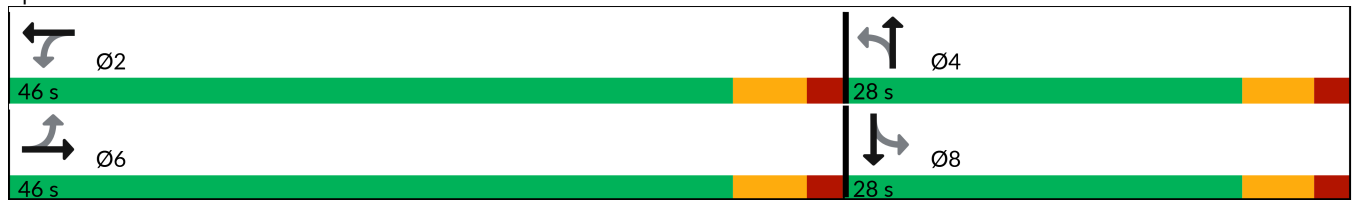

101: Drexel Avenue & 16 Street

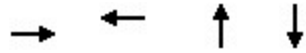

Lane Group	EBT	WBT	NBT	SBT
Lane Group Flow (vph)	296	388	41	70
v/c Ratio	0.33	0.39	0.12	0.19
Control Delay (s/veh)	11.4	11.6	16.7	10.9
Queue Delay	0.0	0.4	0.0	0.0
Total Delay (s/veh)	11.4	11.9	16.7	10.9
Queue Length 50th (ft)	80	106	12	10
Queue Length 95th (ft)	139	178	32	36
Internal Link Dist (ft)	176	70	207	304
Turn Bay Length (ft)				
Base Capacity (vph)	892	991	416	437
Starvation Cap Reductn	0	233	0	0
Spillback Cap Reductn	0	0	0	0
Storage Cap Reductn	0	0	0	0
Reduced v/c Ratio	0.33	0.51	0.10	0.16

Intersection Summary

HCM 7th Signalized Intersection Summary
 101: Drexel Avenue & 16 Street

07/12/2025



Movement	EBL	EBT	EBR	WBL	WBT	WBR	NBL	NBT	NBR	SBL	SBT	SBR
Lane Configurations		↔			↔			↔			↔	
Traffic Volume (veh/h)	57	194	24	21	270	70	21	7	9	22	2	41
Future Volume (veh/h)	57	194	24	21	270	70	21	7	9	22	2	41
Initial Q (Qb), veh	0	0	0	0	0	0	0	0	0	0	0	0
Lane Width Adj.	1.00	1.00	1.00	1.00	1.00	1.00	1.00	1.00	1.00	1.00	1.00	1.00
Ped-Bike Adj(A_pbT)	0.97		0.93	0.97		0.93	0.91		0.87	0.90		0.89
Parking Bus, Adj	1.00	1.00	0.90	1.00	1.00	0.90	1.00	1.00	0.90	1.00	1.00	0.90
Work Zone On Approach		No			No			No			No	
Adj Sat Flow, veh/h/ln	1856	1856	1856	1856	1856	1856	1856	1856	1856	1856	1856	1856
Adj Flow Rate, veh/h	61	209	26	23	290	75	23	8	10	24	2	44
Peak Hour Factor	0.93	0.93	0.93	0.93	0.93	0.93	0.93	0.93	0.93	0.93	0.93	0.93
Percent Heavy Veh, %	3	3	3	3	3	3	3	3	3	3	3	3
Cap, veh/h	199	630	74	80	715	177	231	78	73	147	34	187
Arrive On Green	0.78	0.78	0.78	0.78	0.78	0.78	0.24	0.24	0.24	0.24	0.24	0.24
Sat Flow, veh/h	231	1075	126	41	1218	302	628	330	309	321	145	789
Grp Volume(v), veh/h	296	0	0	388	0	0	41	0	0	70	0	0
Grp Sat Flow(s),veh/h/ln	1431	0	0	1561	0	0	1267	0	0	1255	0	0
Q Serve(g_s), s	0.0	0.0	0.0	0.0	0.0	0.0	0.0	0.0	0.0	0.0	0.0	0.0
Cycle Q Clear(g_c), s	3.6	0.0	0.0	5.4	0.0	0.0	1.4	0.0	0.0	2.8	0.0	0.0
Prop In Lane	0.21		0.09	0.06		0.19	0.56		0.24	0.34		0.63
Lane Grp Cap(c), veh/h	903	0	0	971	0	0	383	0	0	369	0	0
V/C Ratio(X)	0.33	0.00	0.00	0.40	0.00	0.00	0.11	0.00	0.00	0.19	0.00	0.00
Avail Cap(c_a), veh/h	903	0	0	971	0	0	486	0	0	472	0	0
HCM Platoon Ratio	1.33	1.33	1.33	1.33	1.33	1.33	1.00	1.00	1.00	1.00	1.00	1.00
Upstream Filter(I)	1.00	0.00	0.00	1.00	0.00	0.00	1.00	0.00	0.00	1.00	0.00	0.00
Uniform Delay (d), s/veh	3.5	0.0	0.0	3.7	0.0	0.0	20.4	0.0	0.0	20.9	0.0	0.0
Incr Delay (d2), s/veh	1.0	0.0	0.0	1.2	0.0	0.0	0.1	0.0	0.0	0.2	0.0	0.0
Initial Q Delay(d3), s/veh	0.0	0.0	0.0	0.0	0.0	0.0	0.0	0.0	0.0	0.0	0.0	0.0
%ile BackOfQ(95%),veh/ln	2.0	0.0	0.0	2.7	0.0	0.0	0.9	0.0	0.0	1.6	0.0	0.0
Unsig. Movement Delay, s/veh												
LnGrp Delay(d), s/veh	4.5	0.0	0.0	4.9	0.0	0.0	20.5	0.0	0.0	21.1	0.0	0.0
LnGrp LOS	A			A			C			C		
Approach Vol, veh/h		296			388			41				70
Approach Delay, s/veh		4.5			4.9			20.5				21.1
Approach LOS		A			A			C				C
Timer - Assigned Phs		2		4		6		8				
Phs Duration (G+Y+Rc), s		46.0		22.2		46.0		22.2				
Change Period (Y+Rc), s		6.0		6.0		6.0		6.0				
Max Green Setting (Gmax), s		40.0		22.0		40.0		22.0				
Max Q Clear Time (g_c+I1), s		7.4		3.4		5.6		4.8				
Green Ext Time (p_c), s		0.9		0.1		0.7		0.2				
Intersection Summary												
HCM 7th Control Delay, s/veh			7.0									
HCM 7th LOS			A									
Notes												
User approved pedestrian interval to be less than phase max green.												

Intersection						
Int Delay, s/veh	1.7					
Movement	EBL	EBT	WBT	WBR	SBL	SBR
Lane Configurations		↔	↔		↔	↔
Traffic Vol, veh/h	25	202	308	24	29	47
Future Vol, veh/h	25	202	308	24	29	47
Conflicting Peds, #/hr	84	0	0	84	4	4
Sign Control	Free	Free	Free	Free	Stop	Stop
RT Channelized	-	None	-	None	-	None
Storage Length	-	-	-	-	0	0
Veh in Median Storage, #	-	0	0	-	0	-
Grade, %	-	0	0	-	0	-
Peak Hour Factor	92	92	92	92	92	92
Heavy Vehicles, %	3	3	3	3	3	3
Mvmt Flow	27	220	335	26	32	51

Major/Minor	Major1	Major2	Minor2		
Conflicting Flow All	445	0	-	0	710
Stage 1	-	-	-	-	432
Stage 2	-	-	-	-	278
Critical Hdwy	4.13	-	-	-	5
Critical Hdwy Stg 1	-	-	-	-	5
Critical Hdwy Stg 2	-	-	-	-	5
Follow-up Hdwy	2.227	-	-	-	3
Pot Cap-1 Maneuver	1110	-	-	-	593
Stage 1	-	-	-	-	784
Stage 2	-	-	-	-	914
Platoon blocked, %		-	-	-	
Mov Cap-1 Maneuver	1032	-	-	-	498
Mov Cap-2 Maneuver	-	-	-	-	498
Stage 1	-	-	-	-	708
Stage 2	-	-	-	-	850

Approach	EB	WB	SB
HCM Control Delay, s/v	0.95	0	11.05
HCM LOS			B

Minor Lane/Major Mvmt	EBL	EBT	WBT	WBR	SBLn1	SBLn2
Capacity (veh/h)	198	-	-	-	498	769
HCM Lane V/C Ratio	0.026	-	-	-	0.063	0.066
HCM Control Delay (s/veh)	8.6	0	-	-	12.7	10
HCM Lane LOS	A	A	-	-	B	B
HCM 95th %tile Q(veh)	0.1	-	-	-	0.2	0.2

103: Washington Avenue & 16 Street



Lane Group	EBL	EBT	WBL	WBT	WBR	NBL	NBT	SBL	SBT
Lane Configurations		↔		↕	↗	↖	↕↔	↖	↕↔
Traffic Volume (vph)	43	138	102	154	134	51	583	144	576
Future Volume (vph)	43	138	102	154	134	51	583	144	576
Turn Type	Perm	NA	Perm	NA	pm+ov	Perm	NA	pm+pt	NA
Protected Phases		8		4	5		6	5	2
Permitted Phases	8		4		4	6		2	
Detector Phase	8	8	4	4	5	6	6	5	2
Switch Phase									
Minimum Initial (s)	7.0	7.0	7.0	7.0	5.0	7.0	7.0	5.0	7.0
Minimum Split (s)	39.0	39.0	39.0	39.0	11.0	27.0	27.0	11.0	27.0
Total Split (s)	39.0	39.0	39.0	39.0	11.0	70.0	70.0	11.0	81.0
Total Split (%)	32.5%	32.5%	32.5%	32.5%	9.2%	58.3%	58.3%	9.2%	67.5%
Maximum Green (s)	33.0	33.0	33.0	33.0	5.0	64.0	64.0	5.0	75.0
Yellow Time (s)	4.0	4.0	4.0	4.0	4.0	4.0	4.0	4.0	4.0
All-Red Time (s)	2.0	2.0	2.0	2.0	2.0	2.0	2.0	2.0	2.0
Lost Time Adjust (s)		0.0		0.0	0.0	0.0	0.0	0.0	0.0
Total Lost Time (s)		6.0		6.0	6.0	6.0	6.0	6.0	6.0
Lead/Lag					Lead	Lag	Lag	Lead	
Lead-Lag Optimize?					Yes	Yes	Yes	Yes	
Vehicle Extension (s)	2.5	2.5	2.5	2.5	2.0	1.0	1.0	2.0	1.0
Recall Mode	None	None	None	None	None	C-Max	C-Max	None	C-Max
Walk Time (s)	5.0	5.0	5.0	5.0		7.0	7.0		7.0
Flash Don't Walk (s)	28.0	28.0	28.0	28.0		14.0	14.0		14.0
Pedestrian Calls (#/hr)	100	100	100	100		100	100		100

Intersection Summary

Cycle Length: 120
 Actuated Cycle Length: 120
 Offset: 33 (28%), Referenced to phase 2:SBTL and 6:NBTL, Start of Yellow
 Natural Cycle: 80
 Control Type: Actuated-Coordinated

Splits and Phases: 103: Washington Avenue & 16 Street

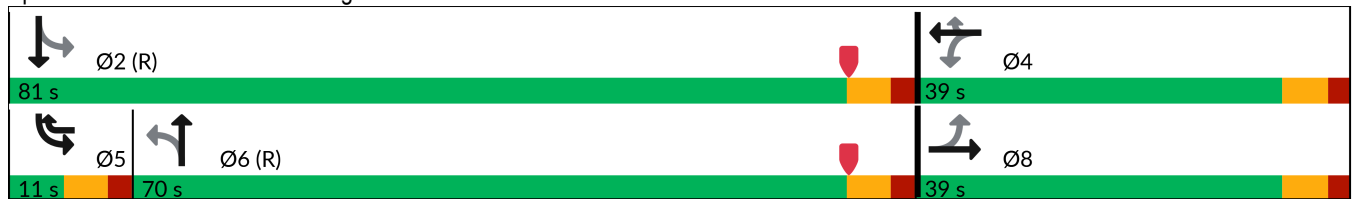

103: Washington Avenue & 16 Street



Lane Group	EBT	WBT	WBR	NBL	NBT	SBL	SBT
Lane Group Flow (vph)	234	261	137	52	762	147	743
v/c Ratio	0.68	0.87	0.31	0.21	0.50	0.48	0.42
Control Delay (s/veh)	48.2	69.4	13.9	17.5	17.9	15.2	11.4
Queue Delay	0.0	0.0	0.0	0.0	0.0	0.0	0.0
Total Delay (s/veh)	48.2	69.4	13.9	17.5	17.9	15.2	11.4
Queue Length 50th (ft)	155	193	29	20	177	44	132
Queue Length 95th (ft)	250	#347	75	47	231	73	174
Internal Link Dist (ft)	170	490			200		499
Turn Bay Length (ft)				120		100	
Base Capacity (vph)	345	301	444	250	1535	306	1753
Starvation Cap Reductn	0	0	0	0	0	0	0
Spillback Cap Reductn	0	0	0	0	0	0	0
Storage Cap Reductn	0	0	0	0	0	0	0
Reduced v/c Ratio	0.68	0.87	0.31	0.21	0.50	0.48	0.42

Intersection Summary

95th percentile volume exceeds capacity, queue may be longer.
Queue shown is maximum after two cycles.

HCM 7th Signalized Intersection Summary
 103: Washington Avenue & 16 Street

07/12/2025

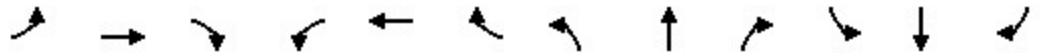

Movement	EBL	EBT	EBR	WBL	WBT	WBR	NBL	NBT	NBR	SBL	SBT	SBR
Lane Configurations		↕			↕	↕	↕	↕↔		↕	↕↔	
Traffic Volume (veh/h)	43	138	48	102	154	134	51	583	164	144	576	152
Future Volume (veh/h)	43	138	48	102	154	134	51	583	164	144	576	152
Initial Q (Qb), veh	0	0	0	0	0	0	0	0	0	0	0	0
Lane Width Adj.	1.00	1.00	1.00	1.00	1.00	1.00	1.00	1.00	1.00	1.00	1.00	1.00
Ped-Bike Adj(A_pbT)	0.96		0.85	0.95		0.85	0.92		0.76	0.98		0.79
Parking Bus, Adj	1.00	1.00	0.90	1.00	1.00	0.90	1.00	1.00	0.90	1.00	1.00	0.90
Work Zone On Approach		No			No			No			No	
Adj Sat Flow, veh/h/ln	1856	1856	1856	1856	1856	1856	1856	1856	1856	1856	1856	1856
Adj Flow Rate, veh/h	44	141	49	104	157	137	52	595	167	147	588	155
Peak Hour Factor	0.98	0.98	0.98	0.98	0.98	0.98	0.98	0.98	0.98	0.98	0.98	0.98
Percent Heavy Veh, %	3	3	3	3	3	3	3	3	3	3	3	3
Cap, veh/h	36	85	23	120	146	391	410	1279	356	425	1543	404
Arrive On Green	0.28	0.28	0.28	0.28	0.28	0.28	0.71	0.71	0.71	0.06	0.83	0.83
Sat Flow, veh/h	0	309	82	283	531	1206	656	2398	668	1767	2469	646
Grp Volume(v), veh/h	234	0	0	261	0	137	52	436	326	147	419	324
Grp Sat Flow(s),veh/h/ln	391	0	0	814	0	1206	656	1763	1303	1767	1763	1352
Q Serve(g_s), s	0.0	0.0	0.0	0.0	0.0	10.5	3.1	12.9	13.1	4.5	7.0	7.1
Cycle Q Clear(g_c), s	33.0	0.0	0.0	33.0	0.0	10.5	3.1	12.9	13.1	4.5	7.0	7.1
Prop In Lane	0.19		0.21	0.40		1.00	1.00		0.51	1.00		0.48
Lane Grp Cap(c), veh/h	143	0	0	266	0	391	410	940	695	425	1102	845
V/C Ratio(X)	1.63	0.00	0.00	0.98	0.00	0.35	0.13	0.46	0.47	0.35	0.38	0.38
Avail Cap(c_a), veh/h	143	0	0	266	0	391	410	940	695	425	1102	845
HCM Platoon Ratio	1.00	1.00	1.00	1.00	1.00	1.00	1.33	1.33	1.33	1.33	1.33	1.33
Upstream Filter(I)	1.00	0.00	0.00	1.00	0.00	1.00	1.00	1.00	1.00	1.00	1.00	1.00
Uniform Delay (d), s/veh	38.3	0.0	0.0	44.8	0.0	31.6	8.6	10.0	10.0	12.0	4.4	4.4
Incr Delay (d2), s/veh	314.4	0.0	0.0	50.0	0.0	0.4	0.6	1.6	2.3	0.2	1.0	1.3
Initial Q Delay(d3), s/veh	0.0	0.0	0.0	0.0	0.0	0.0	0.0	0.0	0.0	0.0	0.0	0.0
%ile BackOfQ(95%),veh/ln	27.4	0.0	0.0	17.2	0.0	5.6	0.9	7.9	6.2	3.0	4.1	3.3
Unsig. Movement Delay, s/veh												
LnGrp Delay(d), s/veh	352.7	0.0	0.0	94.9	0.0	32.0	9.2	11.7	12.3	12.1	5.4	5.7
LnGrp LOS	F			F		C	A	B	B	B	A	A
Approach Vol, veh/h		234			398			814			890	
Approach Delay, s/veh		352.7			73.2			11.8			6.6	
Approach LOS		F			E			B			A	
Timer - Assigned Phs		2		4	5	6		8				
Phs Duration (G+Y+Rc), s		81.0		39.0	11.0	70.0		39.0				
Change Period (Y+Rc), s		6.0		6.0	6.0	6.0		6.0				
Max Green Setting (Gmax), s		75.0		33.0	5.0	64.0		33.0				
Max Q Clear Time (g_c+I1), s		9.1		35.0	6.5	15.1		35.0				
Green Ext Time (p_c), s		1.7		0.0	0.0	2.1		0.0				
Intersection Summary												
HCM 7th Control Delay, s/veh				54.4								
HCM 7th LOS				D								

104: Collins Ave & 16 Street

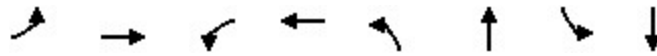

Lane Group	EBL	EBT	WBL	WBT	NBL	NBT	SBL	SBT
Lane Configurations								
Traffic Volume (vph)	148	9	7	6	85	442	18	499
Future Volume (vph)	148	9	7	6	85	442	18	499
Turn Type	Perm	NA	Perm	NA	Perm	NA	Perm	NA
Protected Phases		8		4		6		2
Permitted Phases	8		4		6		2	
Detector Phase	8	8	4	4	6	6	2	2
Switch Phase								
Minimum Initial (s)	7.0	7.0	7.0	7.0	5.0	5.0	5.0	5.0
Minimum Split (s)	26.2	26.2	26.2	26.2	34.2	34.2	34.2	34.2
Total Split (s)	30.0	30.0	30.0	30.0	70.0	70.0	70.0	70.0
Total Split (%)	30.0%	30.0%	30.0%	30.0%	70.0%	70.0%	70.0%	70.0%
Maximum Green (s)	24.0	24.0	24.0	24.0	63.8	63.8	63.8	63.8
Yellow Time (s)	4.0	4.0	4.0	4.0	4.0	4.0	4.0	4.0
All-Red Time (s)	2.0	2.0	2.0	2.0	2.2	2.2	2.2	2.2
Lost Time Adjust (s)	0.0	0.0	0.0	0.0		0.0		0.0
Total Lost Time (s)	6.0	6.0	6.0	6.0		6.2		6.2
Lead/Lag								
Lead-Lag Optimize?								
Vehicle Extension (s)	2.5	2.5	2.5	2.5	1.0	1.0	1.0	1.0
Recall Mode	None	None	None	None	C-Max	C-Max	C-Max	C-Max
Walk Time (s)	7.0	7.0	7.0	7.0	7.0	7.0	7.0	7.0
Flash Don't Walk (s)	13.0	13.0	13.0	13.0	21.0	21.0	21.0	21.0
Pedestrian Calls (#/hr)	100	100	100	100	100	100	100	100

Intersection Summary

Cycle Length: 100
 Actuated Cycle Length: 100
 Offset: 65 (65%), Referenced to phase 2:SBTL and 6:NBTL, Start of Yellow
 Natural Cycle: 65
 Control Type: Actuated-Coordinated

Splits and Phases: 104: Collins Ave & 16 Street

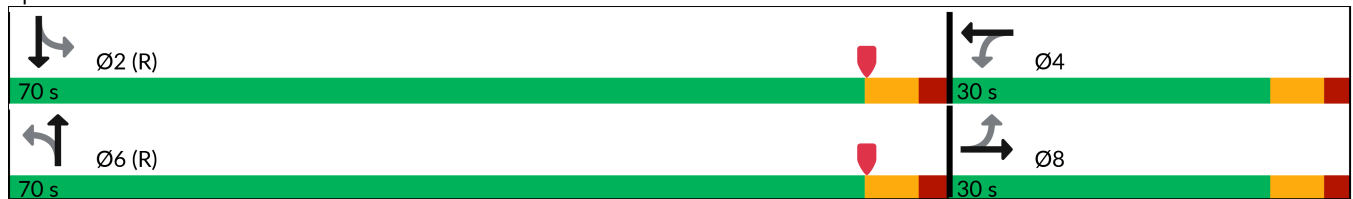

104: Collins Ave & 16 Street



Lane Group	EBL	EBT	WBL	WBT	NBT	SBT
Lane Group Flow (vph)	151	251	7	19	548	719
v/c Ratio	0.81	0.87	0.06	0.08	0.37	0.43
Control Delay (s/veh)	67.8	54.6	31.1	18.4	8.5	7.8
Queue Delay	0.0	0.0	0.0	0.0	0.0	0.0
Total Delay (s/veh)	67.8	54.6	31.1	18.4	8.5	7.8
Queue Length 50th (ft)	89	103	4	3	76	89
Queue Length 95th (ft)	#180	#230	16	22	112	133
Internal Link Dist (ft)		784		333	896	387
Turn Bay Length (ft)	70					
Base Capacity (vph)	219	321	130	289	1500	1661
Starvation Cap Reductn	0	0	0	0	0	0
Spillback Cap Reductn	0	0	0	0	0	0
Storage Cap Reductn	0	0	0	0	0	0
Reduced v/c Ratio	0.69	0.78	0.05	0.07	0.37	0.43

Intersection Summary

95th percentile volume exceeds capacity, queue may be longer.
Queue shown is maximum after two cycles.

HCM 7th Signalized Intersection Summary
 104: Collins Ave & 16 Street

07/12/2025

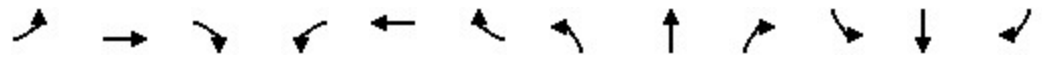

Movement	EBL	EBT	EBR	WBL	WBT	WBR	NBL	NBT	NBR	SBL	SBT	SBR
Lane Configurations	↖	↗		↖	↗			↕			↕	
Traffic Volume (veh/h)	148	9	237	7	6	13	85	442	10	18	499	188
Future Volume (veh/h)	148	9	237	7	6	13	85	442	10	18	499	188
Initial Q (Qb), veh	0	0	0	0	0	0	0	0	0	0	0	0
Lane Width Adj.	1.00	1.00	1.00	1.00	1.00	1.00	1.00	1.00	1.00	1.00	1.00	1.00
Ped-Bike Adj(A_pbT)	0.86		0.84	1.00		0.84	0.93		0.75	0.90		0.75
Parking Bus, Adj	1.00	1.00	0.90	1.00	1.00	0.90	1.00	1.00	0.90	1.00	1.00	0.90
Work Zone On Approach		No			No			No			No	
Adj Sat Flow, veh/h/ln	1670	1670	1670	1670	1670	1670	1670	1670	1670	1670	1670	1670
Adj Flow Rate, veh/h	151	9	242	7	6	13	87	451	10	18	509	192
Peak Hour Factor	0.98	0.98	0.98	0.98	0.98	0.98	0.98	0.98	0.98	0.98	0.98	0.98
Percent Heavy Veh, %	3	3	3	3	3	3	3	3	3	3	3	3
Cap, veh/h	315	9	249	81	89	193	254	1294	29	56	1206	440
Arrive On Green	0.24	0.24	0.24	0.24	0.24	0.24	0.85	0.85	0.85	0.85	0.85	0.85
Sat Flow, veh/h	1069	39	1039	1008	371	804	322	2028	46	29	1890	689
Grp Volume(v), veh/h	151	0	251	7	0	19	257	0	291	448	0	271
Grp Sat Flow(s),veh/h/ln	1069	0	1077	1008	0	1175	1055	0	1341	1634	0	973
Q Serve(g_s), s	12.7	0.0	23.1	0.7	0.0	1.2	1.3	0.0	4.6	0.0	0.0	6.7
Cycle Q Clear(g_c), s	14.0	0.0	23.1	23.8	0.0	1.2	8.0	0.0	4.6	6.3	0.0	6.7
Prop In Lane	1.00		0.96	1.00		0.68	0.34		0.03	0.04		0.71
Lane Grp Cap(c), veh/h	315	0	259	81	0	282	721	0	856	1080	0	621
V/C Ratio(X)	0.48	0.00	0.97	0.09	0.00	0.07	0.36	0.00	0.34	0.41	0.00	0.44
Avail Cap(c_a), veh/h	315	0	259	81	0	282	721	0	856	1080	0	621
HCM Platoon Ratio	1.00	1.00	1.00	1.00	1.00	1.00	1.33	1.33	1.33	1.33	1.33	1.33
Upstream Filter(I)	1.00	0.00	1.00	1.00	0.00	1.00	1.00	0.00	1.00	1.00	0.00	1.00
Uniform Delay (d), s/veh	34.7	0.0	37.7	49.4	0.0	29.4	3.0	0.0	3.1	3.2	0.0	3.2
Incr Delay (d2), s/veh	0.8	0.0	47.6	0.3	0.0	0.1	1.4	0.0	1.1	1.2	0.0	2.2
Initial Q Delay(d3), s/veh	0.0	0.0	0.0	0.0	0.0	0.0	0.0	0.0	0.0	0.0	0.0	0.0
%ile BackOfQ(95%),veh/ln	6.0	0.0	14.4	0.3	0.0	0.6	2.0	0.0	2.2	3.4	0.0	2.3
Unsig. Movement Delay, s/veh												
LnGrp Delay(d), s/veh	35.6	0.0	85.2	49.8	0.0	29.4	4.4	0.0	4.2	4.4	0.0	5.5
LnGrp LOS	D		F	D		C	A		A	A		A
Approach Vol, veh/h		402			26			548			719	
Approach Delay, s/veh		66.6			34.9			4.3			4.8	
Approach LOS		E			C			A			A	
Timer - Assigned Phs		2		4		6		8				
Phs Duration (G+Y+Rc), s		70.0		30.0		70.0		30.0				
Change Period (Y+Rc), s		6.2		6.0		6.2		6.0				
Max Green Setting (Gmax), s		63.8		24.0		63.8		24.0				
Max Q Clear Time (g_c+I1), s		8.7		25.8		10.0		25.1				
Green Ext Time (p_c), s		2.0		0.0		1.6		0.0				
Intersection Summary												
HCM 7th Control Delay, s/veh			19.8									
HCM 7th LOS			B									