



Deerfield Office
 3100 SW 15th Street, Deerfield Beach, FL 33442
 Office: 954.426.1221 | Fax: 954.426.1226

Submittal



Miami Office
 3161 Coral Way STE 611, Miami, FL 33145
 Office: 954.426.1221 | Fax: 954.426.1226

DATE	9/24/2021
TO	CES Consultants 880 SW 145 TH Avenue, Suite 106 Pembroke Pines, FL 33027 Attn: Jose Caraballo
PROJECT	West Avenue, KB 90 & 91
SPECIFICATION	Lighting
TRANSMITTED VIA	e-mail
FOR YOUR	Approval

IF ENCLOSURES ARE NOT INDICATED, PLEASE NOTIFY

--WEST AVE IMPROVEMENTS--

LIGHTING SUBMITTAL

PROJECT:

WEST AVE IMPROVEMENTS

PREPARED BY:

ANIXTER INC., Giovanni Elguezabal 11420 NW 122nd St.

Miami, FL 33178

Lighting Representative: LIGHTWORKS INC., Fabrice Pellegrino



DATE: 09/15/2021

PROJECT: WEST AVENUE IMPROVEMENTS

RE: SUBMITTALS

CONTENTS:

- ROADWAY LUMINAIRE (PAGES 2-12)
 - GL1970 GALLERY SERIES / MATCH EXISTING LED FIXTURE GEN 2 (PAGES 3-8)
 - 7 YEAR WARRANTY (PAGES 9-12)
- ROADWAY POLE / MATCH EXISTING BUT TAPERED (PAGES 13-14)
 - 25FT 0" ROUND ALUMINUM TAPERED POLE 8" TO 4" DIAMETER REPLACES 6" DIAMETER STRAIGHT POLE SINCE IT NO LONGER MEETS 170 MPH AASHTO REQUIREMENTS (PAGE 14)
- ROADWAY ARM (PAGES 15-16)
 - KING LUMINAIRE ARM MATCH EXISTING (PAGE 16)
- PEDESTRIAN LUMINAIRE/ MATCH EXISTING (PAGES 17-19)
 - POULSEN LED VERSION WATTAGE REVISED.
 - POLE AND LUMINAIRE DRAWING
- POLE CALCULATIONS ROADWAY POLE (PAGES 20-34)
- CONCRETE BASE 7FT DEEP/ MATCH CITY STANDARD SPEC. (PAGES 25-26)
- PAINT SPECS (PAGES 37-40)
 - AS PER NEW REQUIREMENT LIGHTING SPECS MARINE GRADE POWDER COAT FINISH

Palm Beach

2721 Vista Parkway, Suite C-11
West Palm Beach, FL 33411
Tel. (561) 641-5570
Fax. (561) 763-7365

Miami-Dade

7035 SW 47th Street, Ste A
Miami, FL 33155
Tel. (305) 456-3520
Fax. (305) 676-8994



lightworks
Smart Technologies. **Bright** Solutions.

ROADWAY LUMINAIRE
STERNBERG LIGHTING
GALLERY SERIES
CAT# 1970LED
MATCH EXISTING

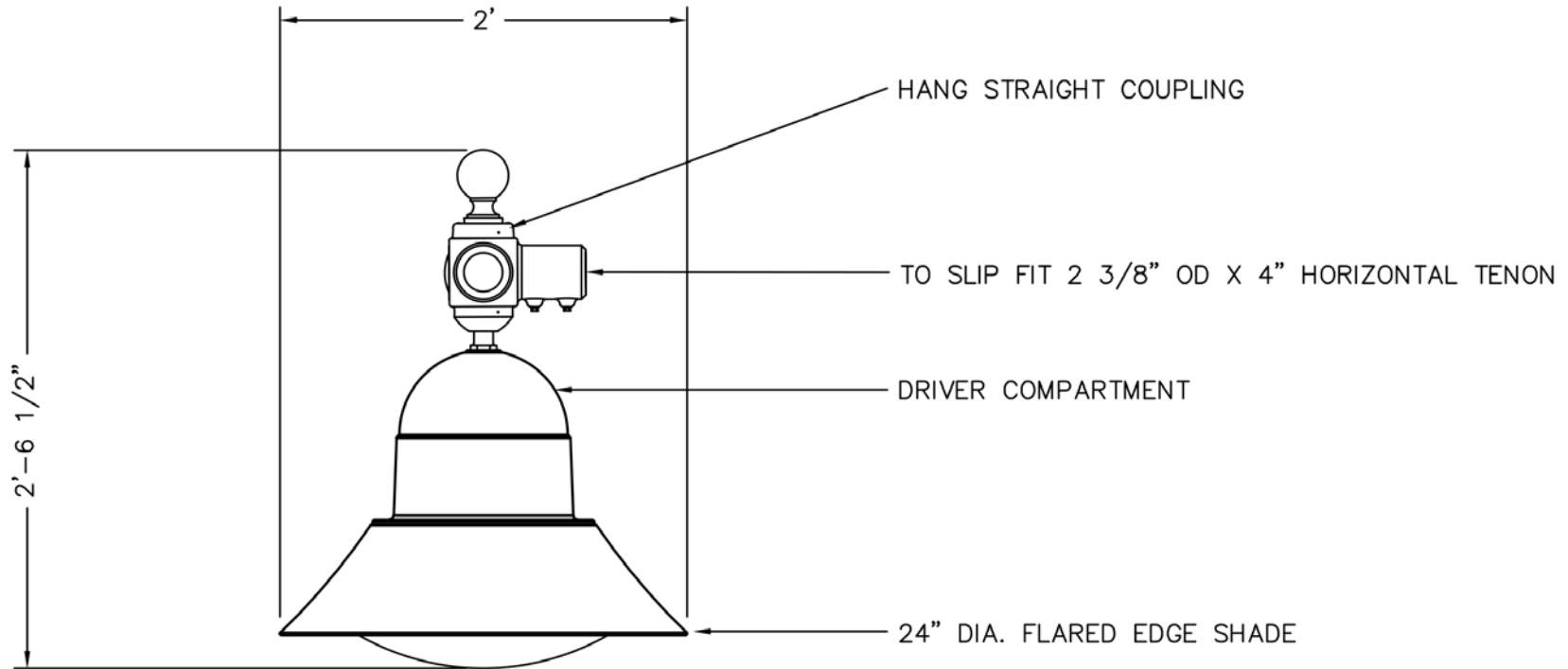

PLEASE CONFIRM
 SAG ACRYLIC LENS (EXISTING) **OR** SV1 FLAT LENS
 FOR FULL CUT-OFF

REVISED LIGHT ENGINE SEE SPEC SHEET

REV	REVISIONS	DATE	RVSD	MIAMI BEACH, FL WEST AVE IMPROVEMENTS	POLE HEIGHTS HAVE A TOLERANCE OF + OR - 2"	DRAWN RB
A	ORIGINAL	5/8/15				
B	CHANGED FIXTURE	8/16/21	JG	1A-GL1970LED-F-BFS-40L40T3-MDL016-SA-HSHB/STD		
				SternbergLighting ESTABLISHED 1923 / EMPLOYEE OWNED		DRAWING NUMBER SC23702-6



GL1970 GALLERY SERIES

LED

EPA
0.9 (ft²)
WEIGHT
56 LBS

7 YEAR
WARRANTY

LUMEN
RANGE
6,670 to
21,845
@4000K

LUMEN
MAINTENANCE
L70 MINIMUM
100,000
HOURS

CLICK
FOR FAQ'S

RATED
IP66

JOB NAME

FIXTURE TYPE

MEMO

BUILD A PART NUMBER

ORDERING EXAMPLE: **2A-GL1970-S-SRS-4OL4OT5-MDLO16-CA-R7-PE-HSHN/CA6/5218P5/UBKT**

Mounting Config.	Luminaire	Shade Style	Housing	LED	CCT	Type	Driver	Lens	Optional Control Receptacle	Optional Control	Option Fuse	Option Hang-straight	Option House Side Shield	Arm See Arm Spec Sheets	Pole See Pole Spec Sheets	Finish

Mounting Configuration

(Click here to link to mounting configuration specification page)

- 1W
- 1A
- 2A
- 2A90
- 3A
- 3A90
- 4A
- 1AM
- 2AM
- SH44¹
- CH44¹
- CAT

W = Wall Mount A = Arm Mount AM = Arm Mid-Mount
SH = Stem Hung CH = Chain Hung CAT = Catenary

¹ Include overall drop length in inches after designation for Stem/Chain application (IE: CH44-48").

Luminaire

- **GL1970**

Shade Style

- S (Straight Edge)
- **F (Flared Edge)**
- B (Bell Edge)
- RR (Round with Round Rim)
- RF (Round with Flared Rim)
- RS (Round with Square Rim)

Housing

- BFR (Base Fixture Round)
- **BFS (Base Fixture Stepped)**
- GRR (Glow Rings Round)
- GRS (Glow Rings Stepped)
- SRR (Solid Rings Round)
- SRS (Solid Rings Stepped)
- GWR (Glow Window Round)
- GWS (Glow Window Stepped)

LED

- 16L²
- 24L³
- 32L²
- **40L⁴**

² Only available with MDLO12.

³ Only available with MDLO10 and MDLO14.

⁴ Only available with MDLO12 and MDLO16.

CCT - Color Temperature (K)

- 27(00)
- **40(00)**
- 30(00)
- 50(00)
- 35(00)

Type

- T2
- **T3**
- T4
- T5

Driver

- MDLO10 (120V-277V, 100mA)
- MDHO10 (347V-480V, 100mA)
- MDLO12 (120V-277V, 120mA)

- MDHO12 (347V-480V, 120mA)
- MDLO14 (120V-277V, 140mA)
- MDHO14 (347V-480V, 140mA)
- **MDLO16 (120V-277V, 160mA)**
- MDHO16 (347V-480V, 160mA)

Lens

- CA (Clear Acrylic)
- SA (Sag Acrylic)
- **SV1 (Flat Soft Vue Medium Diffused Acrylic Lens)**
- SV2 (Flat Soft Vue Heavy Diffused Acrylic Lens)
- SV4 (Flat Soft Vue Maximum Diffused Acrylic)
- SVISA (Soft Vue Light Diffused Sag Acrylic)
- SV2SA (Soft Vue Moderate Diffused Sag Acrylic)
- SV4SA (Soft Vue Maximum Diffused Sag Acrylic)

Options (Click here to view accessories sheet)

- R7⁵ 7-Pin control receptacle only
- PE⁶ Twist-Lock Photocontrol (120v-277v)
- PE3⁶ Twist-Lock Photocontrol (347v)
- PE4⁶ Twist-Lock Photocontrol (480v)
- SC⁶ Shorting Cap
- PEC Electronic Button Photocontrol (120v-277v)
- PEC4 Electronic Button Photocontrol (480v)
- FHD⁷ Double Fuse and Holder
- HSHS Standard Horizontal Hangstraight, Spike Finial
- HSHN Standard Horizontal Hangstraight, No Finial
- **HSHB Standard Horizontal Hangstraight, Ball Finial**
- EZ Vertical Hangstraight, Large, "EZ" Mount
- HSS 120° House Side Shield
- BLOC⁸ Back Light Optical Control

⁵ Only available with HSHL.

⁶ Requires control receptacle.

⁷ Ships loose for installation in base.

⁸ Only available with T2, T3 and T4.

Arm (Click here to link to arm specification page)

See Arms & Wall Brackets specification sheets.

- CA
- CSA
- FFA
- R2⁹
- DAG
- RA
- CAS
- R3⁹

⁹ Luminaires above grade height to be 2' higher than pole height, REQUIRES "EZ" hangstraight.

Pole (Click here to link to pole specification page)

See Pole specification sheets.

Finish

Standard Urban Finishes (Click here to view paint finish sheet)

- UGMT Gun Metal Textured
- UGM Gun Metal Matte
- UBT Urban Bronze Textured
- UB Urban Bronze Matte
- ULBT Urban Light Bronze Textured
- ULB Urban Light Bronze Matte
- USLT Urban Silver Textured
- USL Urban Silver Matte
- UWHT Urban White Textured
- UWH Urban White Matte
- UCHS Urban Champagne Satin Smooth
- **BKT Black Textured**

Custom Urban Finishes¹⁰

- CM Custom Match

¹⁰ Smooth finishes are available upon request.

Specifications

Luminaire

The Gallery GL1970 series is a large scale, decorative pendant luminaire with a cast aluminum driver housing and spun aluminum shades. The housing is available in two styles (Stepped and Round), each with 4 variations (BF_, GR_, SR_ and GW_). The shades are available in six styles: Straight (S), Flared (F), Bell (B), Round with Round rim (RR), Round with Flared rim (RF), and Round with Square rim (RS). The luminaire measures 24" diameter and 18" overall height. The Luminaire shall be UL listed in US and Canada.

LEDs

The luminaire shall use high output, high brightness LEDs. The LEDs are mounted to maximize thermal transfer to the heat sink surface. The LEDs shall be 100% recyclable; not contain lead, mercury or any other hazardous substances and shall be RoHS compliant. Lumen maintenance shall be determined in accordance with IESNA TM-21, based on LED manufacturer LM-80 test data of no less than 6,000 hours and in-situ testing of the luminaire by an NVLAP accredited Energy Efficient Lighting Products lab. The high-performance

See next page



Sternberg Lighting

ESTABLISHED 1923

800-621-3376
555 Lawrence Ave., Roselle, IL 60172
contactus@sternberglighting.com
www.sternberglighting.com

8/21 STERNBERG LIGHTING. ALL RIGHTS RESERVED. PRINTED IN THE USA.

GL1970 GALLERY SERIES

LED

white LEDs will have a predicted lumen depreciation of approximately 100,000 hours with greater than 70% of initial output at 25°C. The high-brightness, high-output white LEDs shall be 4000K nominal (2700K, 3000K, 3500K or 5000K optional) correlated color temperature (CCT) with a 70 (minimum) color rendering index (CRI). Consult factory for custom CCT or CRI. The luminaire shall have a minimum _____ (see table) delivered initial lumens when operated at steady state with an average ambient temperature of 25°C (77°F).

Optics

The luminaire shall be provided with individual, refractor type optics applied to each LED. The luminaire shall provide Type ____ (2, 3, 4 or 5) light distribution per the IESNA classifications. Testing shall be done in accordance with IESNA LM-79.

Electronic Drivers

The LED driver shall be U.L. Recognized. It shall be securely mounted inside the fixture, for optimized performance and longevity. It shall be supplied with a quick-disconnect electrical connector on the power supply, providing easy power connections and fixture installation. It shall have overload, overheat and short circuit protection, and have a DC voltage output, constant current design, 50/60HZ. It shall be supplied with line-ground, line-neutral and neutral-ground electrical surge protection in accordance with IEEE/ANSI C62.41.2 guidelines. It shall be a high efficiency driver with a THD less than 20% and a high power factor greater than .9. It shall be dimming capable using a 0-10v signal, consult factory for more information.

Photocontrols

Button Style: The photocontrol shall be mounted on the fixture and pre-wired to driver.

The electronic button type photocontrol is instant on with a 5-10 second turn off, and shall turn on at 1.5 footcandles with a turn-off at 2-3 footcandles. See pole spec sheet for pole mounted version.

Twist-Lock Style: The photocontrol shall be mounted externally on the hangstraight and pre-wired to driver. The twist lock type photocontrol is instant on with a 3-6 second turn off, and shall turn on at 1.5 footcandles with a turn-off at 2-3 footcandles.

Warranty

Seven-year limited warranty. See product and finish warranty guide for details.

Finish

Refer to website for details.

Performance

MODEL #	T2 LUMENS	BUG	EFFICACY (LPW)	T3 LUMENS	BUG	EFFICACY (LPW)	T4 LUMENS	BUG	EFFICACY (LPW)	T5 LUMENS	BUG	EFFICACY (LPW)	WATTS
40L40T_-MDL016	21710	B3U0G3	124.8	21240	B3U0G3	122.1	21105	B3U0G3	121.3	21845	B4U0G2	125.5	174
40L30T_-MDL016	20700	B3U0G3	119.0	20250	B3U0G3	116.4	20125	B3U0G3	115.7	20830	B4U0G2	119.7	174
40L27T_-MDL016	18715	B3U0G3	107.6	18310	B3U0G3	105.2	18195	B3U0G3	104.6	18830	B4U0G2	108.2	174
40L40T_-MDL012	17040	B3U0G3	137.4	16510	B3U0G3	133.1	16530	B3U0G3	133.3	17155	B4U0G2	138.3	124
40L30T_-MDL012	16245	B3U0G3	131.0	15740	B3U0G3	126.9	15760	B3U0G3	127.1	16355	B4U0G2	131.9	124
40L27T_-MDL012	14690	B3U0G3	118.5	14235	B3U0G3	114.8	14250	B3U0G3	114.9	14790	B4U0G2	119.3	124
32L40T_-MDL012	13650	B2U0G2	136.5	13290	B3U0G3	132.9	13300	B2U0G2	133.0	13840	B3U0G2	138.4	100
32L30T_-MDL012	13015	B2U0G2	130.2	12670	B3U0G3	126.7	12680	B2U0G2	126.8	13195	B3U0G2	132.0	100
32L27T_-MDL012	11765	B2U0G2	117.7	11455	B3U0G3	114.6	11465	B2U0G2	114.7	11930	B3U0G2	119.3	100
24L40T_-MDL014	11535	B2U0G2	131.1	11275	B2U0G2	128.1	11270	B2U0G2	128.1	11650	B3U0G2	132.4	88
24L30T_-MDL014	11000	B2U0G2	125.0	10750	B2U0G2	122.2	10745	B2U0G2	122.1	11110	B3U0G2	126.3	88
24L27T_-MDL014	9945	B2U0G2	113.0	9720	B2U0G2	110.5	9715	B2U0G2	110.4	10045	B3U0G2	114.1	88
24L40T_-MDL010	8950	B2U0G2	144.4	8440	B2U0G2	136.1	8445	B2U0G2	136.2	8690	B3U0G1	140.2	62
24L30T_-MDL010	8535	B2U0G2	137.7	8045	B2U0G2	129.8	8050	B2U0G2	129.8	8285	B3U0G1	133.6	62
24L27T_-MDL010	7715	B2U0G2	124.4	7275	B2U0G2	117.3	7280	B2U0G2	117.4	7490	B3U0G1	120.8	62
16L40T_-MDL012	6815	B1U0G1	133.6	6670	B2U0G2	130.8	6690	B1U0G2	131.2	6860	B3U0G1	134.5	51
16L30T_-MDL012	6500	B1U0G1	127.5	6360	B2U0G2	124.7	6380	B1U0G2	125.1	6540	B3U0G1	128.2	51
16L27T_-MDL012	5875	B1U0G1	115.2	5750	B2U0G2	112.7	5765	B1U0G2	113.0	5915	B3U0G1	116.0	51

Shade Style



Straight Edge (S)



Flared Edge (F)



Bell Edge (B)



Round with Round Rim (RR)



Round with Flared Rim (RF)



Round with Square Rim (RS)

Dimensions

GL1970	SHADE	S	F	B	RF	RR	RS
HOUSING	Diameter	23.9"	23.9"	26"	25"	24.5"	23.8"
BF_	Height	17.9"	16.6"	18.2"	19.6"	19.1"	18.6"
GR_	Height	17.9"	16.6"	18.2"	19.6"	19.1"	18.6"
GW_	Height	17.9"	16.6"	18.2"	19.6"	19.1"	18.6"
SR_	Height	17.9"	16.6"	18.2"	19.6"	19.1"	18.6"



Housing - Stepped



Base Fixture Stepped (BF5)



Glow Window Stepped (GWS)



Solid Rings Stepped (SRS)



Glow Rings Stepped (GRS)





lightworks
Smart Technologies. **Bright** Solutions.

**STERNBERG LIGHTING
7 YEAR WARRANTY / LED**



SternbergLighting

ESTABLISHED 1923 / EMPLOYEE OWNED

Sternberg Lighting's Warranty Information

Effective on all shipments after 3/7/2005

Since 1923, Sternberg has earned a reputation throughout the electrical industry for high quality products and service. We warrant that our products are manufactured in accordance with its applicable material specifications and are free from defects in materials and workmanship. Sternberg will, at its option, either repair or replace without charge, any properly installed Sternberg product that fails under normal operating conditions within five years from date of purchase. Product must be returned, freight prepaid, to our plant and our inspection must determine that it is defective under the terms of warranty.

For example, the following components and their warranty periods are as follows:

LED Diode Systems and Drivers - 7 years (Effective on all shipments after 5/1/2010)

The luminaire shall be free from all defects in materials and workmanship for a period of seven (7) years from the date of manufacture. The luminaire manufacturer shall warrant the LED boards/system, during the stated warranty period, against failure defined as more than 10 percent non-operating LEDs. The driver shall be warranted for seven (7) years.

Ballasts: Magnetic - 2 years, Electronic - 3 years.

Photocells: 2 years.

PL & HID Lamps: 1 year.

Induction Lighting Systems and Components: 5 years.

Clock Motor, GPS and Controls: 1 year

Clock Structure and Finish: 5 years

This warranty is only for product manufactured by Sternberg and does not extend to transportation, installation or replacement charges, nor does it apply to any equipment of another manufacturer used in conjunction with Sternberg equipment.

This warranty specifically excludes fatigue failure or similar phenomena resulting from induced vibration, harmonic oscillation or resonance associated with movement of air currents around the product. The above warranties are given in lieu of all other warranties express or implied, including without limitation, the warranty of merchantability and the warranty of suitability for a particular purpose. It is expressly stated that Sternberg assumes no liability for consequential or liquidated damages arising out of a breach of sale, including any warranties arising there from, and buyer's remedy shall be limited to repair or replacement of defective parts as described above.

Sternberg Lighting Inc. warrants that for a period of five (5) years* (the "Limited Warranty Period") from the date of shipment, that Sternberg's Paint Finish:

- Will not fade in color more than five units as measured by Hunter L*a*b* Color Difference as set forth in ASTM D2244 Section 6.3 as of the date of this letter and in such a way as to significantly adversely affect the appearance of the surface to which the product has been applied and result in damage to the surface;
- Will exhibit gloss retention of a minimum of 30% of the original as measured in accordance with ASTM D523 using 60 degree readings;
- Will not chalk in excess of standard number 8 rating for colors, No. 6 for whites as illustrated in the ASTM D4214 Test Method A.
- Will not corrode or exhibit a lack of adhesion.

* Sternberg Steel Poles are limited to a one (1) year warranty. Longer warranty periods are available based on selection of various optional surface preparation requirements for a particular geographic location. Consult factory for details.

[Concrete Pole Warranty Click Here](#)

[Timberwood Pole Warranty Click Here](#)

MEASUREMENTS: Color measurements (delta E) are measured at 10 degrees and on exposed coated surfaces that have been cleaned of all external deposits including chalk and compared to the original unexposed coated surface. For comparison purposes, Sternberg will maintain a standard paint panel and/or documentation indicating color, gloss and other properties. It is understood that fading may not be uniform if the coated surfaces are not equally exposed to the sun and weathering elements. Prior to the determination of a gloss value using an angle of incidence of 60 degrees following ASTM D523, the surface must be cleaned using a 1% aqueous solution of a wetting agent with a soft sponge under light pressure. This warranty extends only to parts exposed to normal atmospheric conditions in the United States. In addition, a systematic maintenance program must be instituted to clean the surface periodically so as to prevent accumulations of salt deposits and harmful pollutants.

Suggested maintenance program

- Clean water with slight amounts of mild alkaline detergents must be used.
- The cleaning effect maybe increased by rubbing with a soft, non-scratching cloth or cotton with modest pressure.
- The temperature of the parts to be cleaned must not exceed 80 F.
- For removal of grease and oily substances isopropyl alcohol may be used.
- The cleaning solution must not be allowed to react for more than one (1) hour.
- After cleaning, the surfaces must be rinsed with clean cold water.
- A proper maintenance record has to be kept and documented. This documentation must contain the following information:
 - *Date*
 - *Name and Address of performing party*
 - *Description of cleaning procedure and detergents used*
 - *Signature of person performing the cleaning procedure*

This warranty does not extend to

- a. Damage to the coating caused by moisture or other contamination during storage of the product.
- b. Corrosion, peeling, flaking or discoloration caused by acts of God, such as but not limited to acid rain, hail, tree sap, flooding or airborne objects.
- c. Damage caused by accident, vandalism, damage caused by installation, signage or any other foreign equipment attached to the product.
- d. Products not supplied by Sternberg that are attached or used in conjunction with our product.
- e. Loss of use or loss profit, or any other consequential damages.
- f. Improper cleaning or maintenance.

Claim Procedure

In the event of a claim, claimant shall demonstrate that the failure of the product was due to a breach of this warranty and furnish proof of purchase of the defective Sternberg product, including order number. Claims must be made in writing within thirty days after the customer becomes aware of the failure or potential failure of the coating. Sternberg must be given an opportunity to inspect the coating or product that forms the basis for the claim, as well as records and documents concerning maintenance that relate to the coated part or manufactured product that is the subject of the claim, all of which records and documents must be maintained by the customer for a claim to be valid.

Your exclusive remedy under this warranty or otherwise and Sternberg's sole liability shall be limited to, at Sternberg's sole discretion, the reimbursement of repair costs, replacement of the defective material at our expense or a refund of that portion of the purchase price attributable to the defective material.

Sternberg shall not be liable for incidental, special or consequential damages. This warranty is extended to you, the direct purchaser of the products from Sternberg, and is not transferable or assignable. No other warranty, express or implied, is given, including without limitation any implied warranty of merchantability or fitness for a particular purpose, and no terms or conditions other than those stated herein shall be binding on Sternberg. This warranty may be modified only by a writing signed by an authorized representative of Sternberg.

Terms & Conditions

Catalog Information: The product information published in our catalogs and literature is not guaranteed. It has been compiled with care and is sufficiently accurate for most purposes. It is subject to change without notice. Occasionally, it may be necessary to modify the components, materials or finishes of the product. These changes will in no way reduce the function or performance for which the product is intended. All statements, technical information and recommendations contained in our literature are based on information and tests we believe to be reliable. The accuracy or completeness thereof are not guaranteed. In accordance with Sternberg's Terms and Conditions of Sale, and since conditions of use are outside our control, the purchaser should determine the suitability of the product for his/her intended use and assumes all risk and liability whatsoever in connection therewith. All sales of Sternberg products are specifically subject to the Terms and Conditions of Sales described here.

Measurements: Dimensions in our catalogs and literature are approximate, and should not be used for construction purposes. Consult "project specific" engineering submittal drawings and anchor bolt templates for construction dimensions.

Order Cancellation or Modification: Due to the wide selection of Sternberg product offering and options, all products are built to order. Buyer may not cancel or modify an order unless buyer has received prior written approval from Sternberg. In the event of any cancellation or modification without prior written approval from Sternberg, buyer shall be obligated to pay a substantial cancellation charge. Hold for Release orders expire 6 months after receipt by factory and may be subject to requote or cancellation if not released.

Sales Taxes: State and local taxes apply if applicable.

Freight Terms: All shipments will be FOB origin. Most orders will be shipped common carrier and freight prepaid (freight allowed) by Sternberg. Consult buyer's quotation for the specific freight terms. No carrier accounts or specific carrier requests accepted. Additional freight charges to the buyer may be applicable for reconsigned or storage charges. Residential shipments will incur a \$100 surcharge, per shipment. For all common carrier shipments it is the buyer's responsibility to unload the goods immediately upon delivery. Ownership of the goods passes to the buyer as soon as they leave the factory. Please contact our customer service department for any shipping assistance.

Lamps: Screw in lamps not provided by factory.

Pricing: All prices quoted are in United States currency unless otherwise stated on our quotation.

Order Approval: All orders are subject to credit review and approval. Custom orders, vaguely detailed or unclear orders are required by Sternberg to have the specifier approve, sign and return Sternberg's submittal drawing prior to production. Lead times quoted exclude the order approval process.

Anchor Bolts: Sternberg, upon request, and for approved orders, will ship anchor bolts ahead of the pole shipment to aid buyer in site preparation. Unless otherwise stated, no additional freight charge will be assessed for this service.

Return Policy: No merchandise may be returned by buyer without written authorization in the form of a Return Goods Authorization (RGA), which has been issued by Sternberg expressly for the merchandise to be returned. This RGA will be issued at the sole discretion of Sternberg. Sternberg products are built to customer's order, and Sternberg does not stock any finished products due to customers highly optioned and customized choices. For these reasons, Sternberg will not consider product returns unless claimed to be defective in workmanship or materials. Merchandise accepted for return must be shipped prepaid to the factory or other destination specified by Sternberg.

Shipment Dates: Shipping dates are approximate and are based on conditions existing at the time of Sternberg's receipt of buyer's firm order and order approval. Sternberg will in good faith endeavor to ship by the estimated shipping date but shall not be responsible for any delay or any damage arising therefrom.

Minimum Order Charge: Orders must total at least \$50.00 in value.



ROADWAY POLE

**FLAGPOLES ALUMINUM ROUND TAPERED
8" TO 4" DIAMETER REPLACES 6" DIAMETER STRAIGHT ROUND
(EXISTING STRAIGHT ROUND DID NOT MEET NEW WIND
REQUIREMENTS 170 MPH AASHTO)**

- STRESSCRETE GROUP
ORNAMENTAL LIGHTING ARM, HUB & SCROLL
PER DWG. # 206A9835-4B
NOT INCLUDED
- STERNBERG LIGHTING FIXTURE
PER DWG. # SC23702-6
NOT INCLUDED

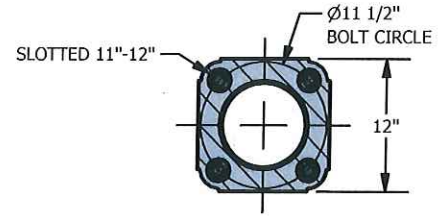
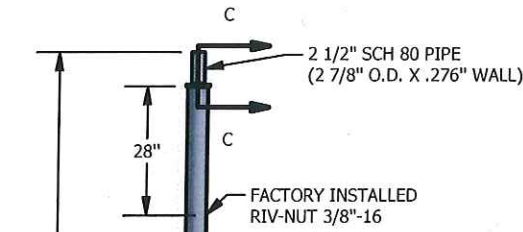

SECTION B-B
SCALE 0.06 : 1

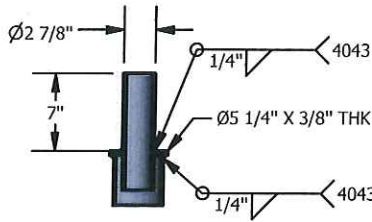

SECTION C-C
SCALE 0.06 : 1

TAPERED SHAFT IS REQUIRED IN LIEU OF STRAIGHT 6" DIA; TO MEET WINDLOADING REQUIREMENTS / SEE CALCULATIONS



**SERIES 38 - SEE SPECS
POWDER COAT FINISH/
MARINE GRADE AS PER NEW
SPECS/REPORT**

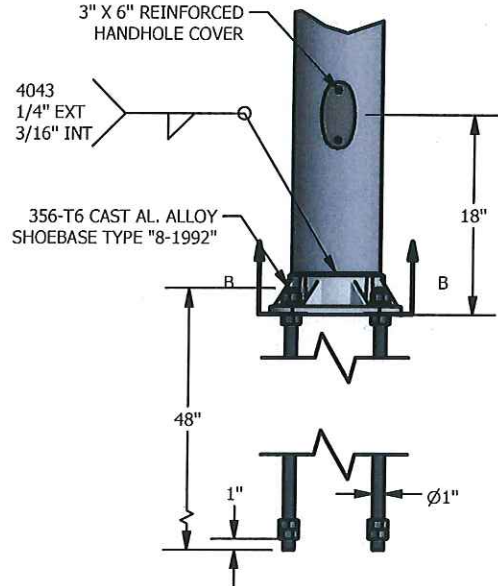

DETAIL A
SCALE 0.06 : 1

ANCHOR BOLTS PER ASTM F1554GR55, FULLY GALVANIZED PER ASTM A153 WITH ALL NUTS, FLATWASHERS, AND LOCKWASHERS

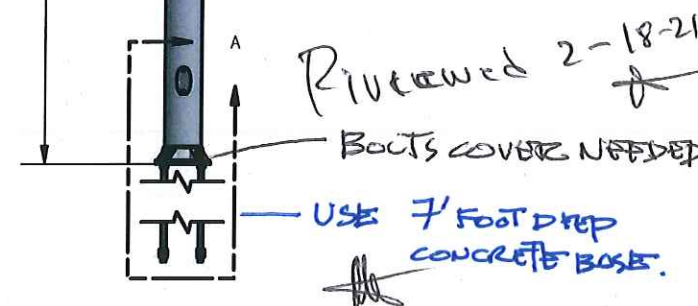

		95 GNARLED HOLLOW RD. EAST SETAUKET, N.Y. 11733	
PROJECT: MIAMI BEACH, PWD		DIST:	
CONTRACTOR:		AGENT: LIGHTWORKS	
DRAWN BY: RM	DATE: 12/23/2019	MATERIAL: AS NOTED	
CHK'D BY: SAF	APP'D:	DRAWING #:	
SCALE: AS NOTED	WORK ORDER #: 57560	16348	

REVISION HISTORY		
REV	DESCRIPTION	DATE
-	INITIAL RELEASE	12/23/2019



lightworks
Smart Technologies. **Bright** Solutions.

ROADWAY ARM
MATCH EXISTING
STRESSCRETE

REV.	ALTERATION	DATE	BY
A	REMOVED SCROLL	06/26/20	MAK

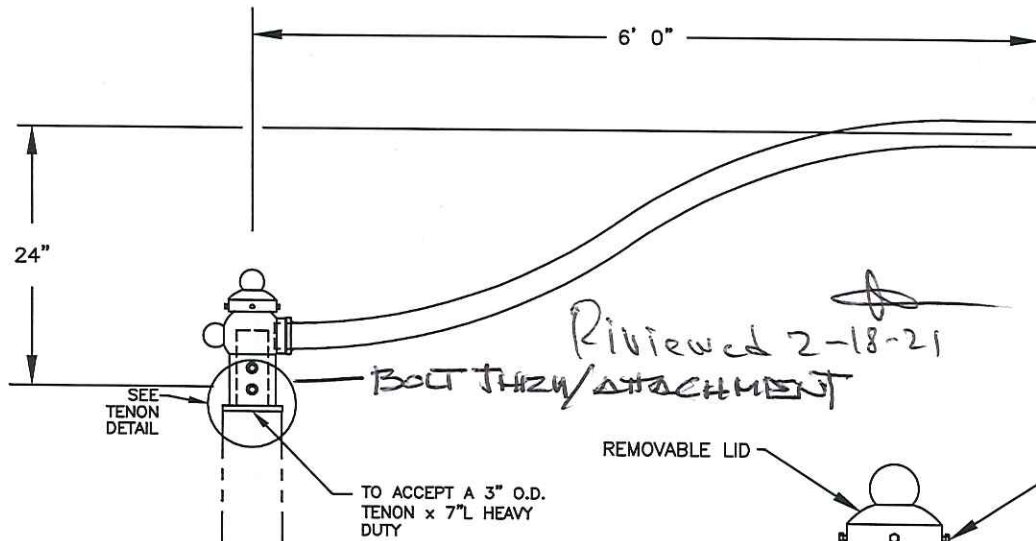

ARM SPECIFICATIONS

CATALOGUE NO.: (MOD) KA30-T-1-6'
 QUANTITY:
 MATERIAL: ALUMINUM
 PAINT: SEE CHART
 ARM EPA: 3.44 FT²
 ARM WEIGHT: 25 LB

PAINT OPTIONS:	
<input checked="" type="checkbox"/>	TEXTURED BLACK
<input type="checkbox"/>	TEXTURED WHITE

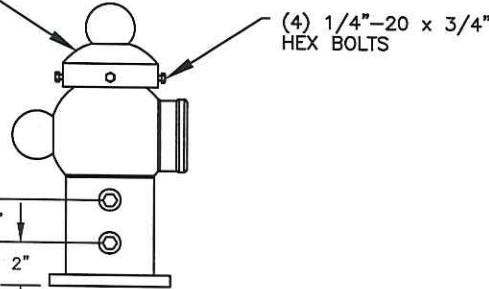

SECTION
(SCALE 2:1)

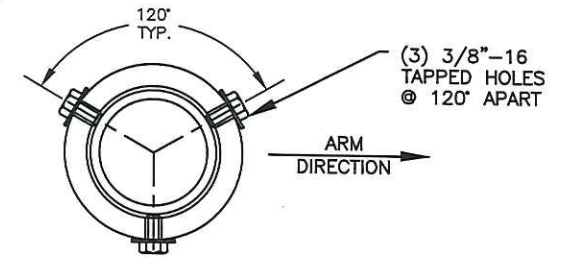

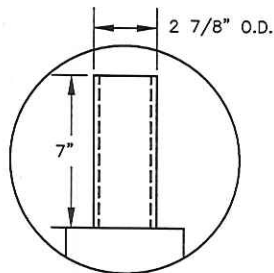

TOP VIEW (FOR TENON)
(SCALE 4:1)

**SERIES 38 - SEE SPECS
 POWDER COAT FINISH/
 MARINE GRADE AS PER NEW
 SPECS/REPORT**



TENON DETAIL
(SCALE 2:1)

CUSTOMER APPROVAL & DATE: _____

  King Luminaire • Stresscrete • Est. 1955 STRESSCRETE GROUP		Manufacturing Locations: Burlington, Ontario 1-800-268-7809 Northport, Alabama 1-800-435-6563 Atchison, Kansas 1-800-837-1024 Jefferson, Ohio 1-800-268-7809		
		PROJECT/CUSTOMER: CITY OF MIAMI BEACH		
CUSTOMER ORDER No: KMFG. ORDER No: KING U.S. ORDER No:	DRAWN BY: D.D.	AT: SC1	CHECKED BY: DATE: 11/26/19	REVISION: A
DRAWING TYPE: CONCEPT DRAWING			DRAWING NUMBER: 206A9835-4B	



lightworks
Smart Technologies. **Bright** Solutions.

**PEDESTRIAN LUMINAIRE
POULSEN – MATCH EXISTING
REVISED WATTAGE FOR LED
COLOR BLACK**

VER	BY	DATE	DESCRIPTION
01	ARU	11/9/20	UPDATED FINISH TO TIGER DRYLAC BLACK

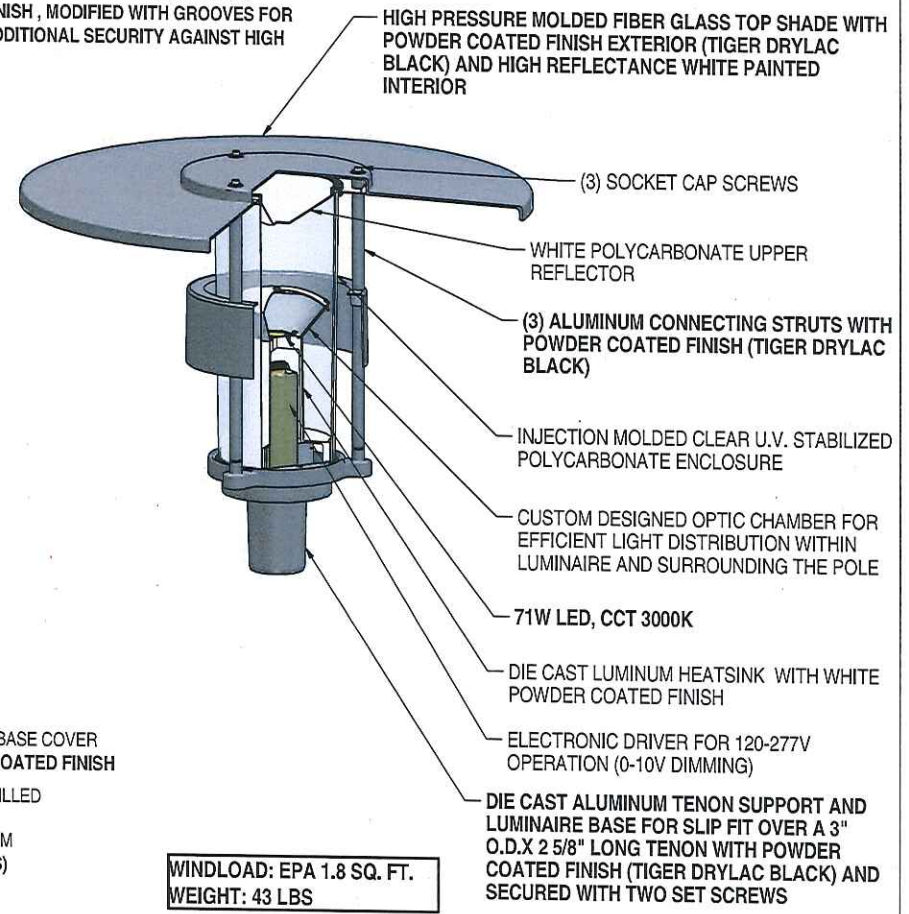
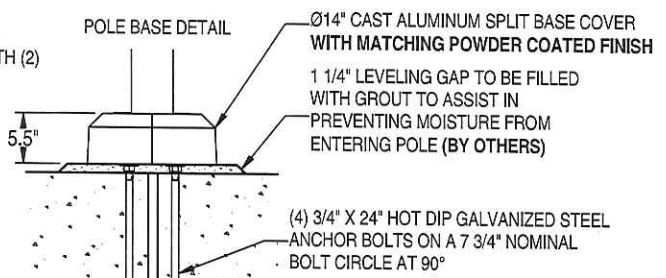
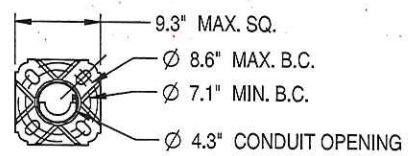
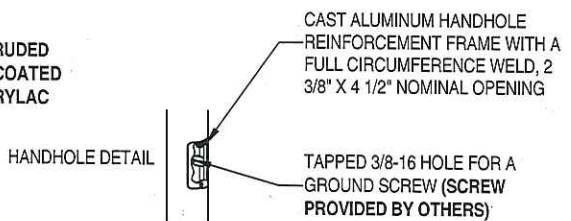
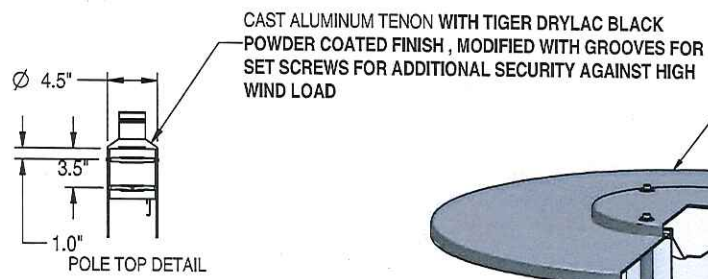
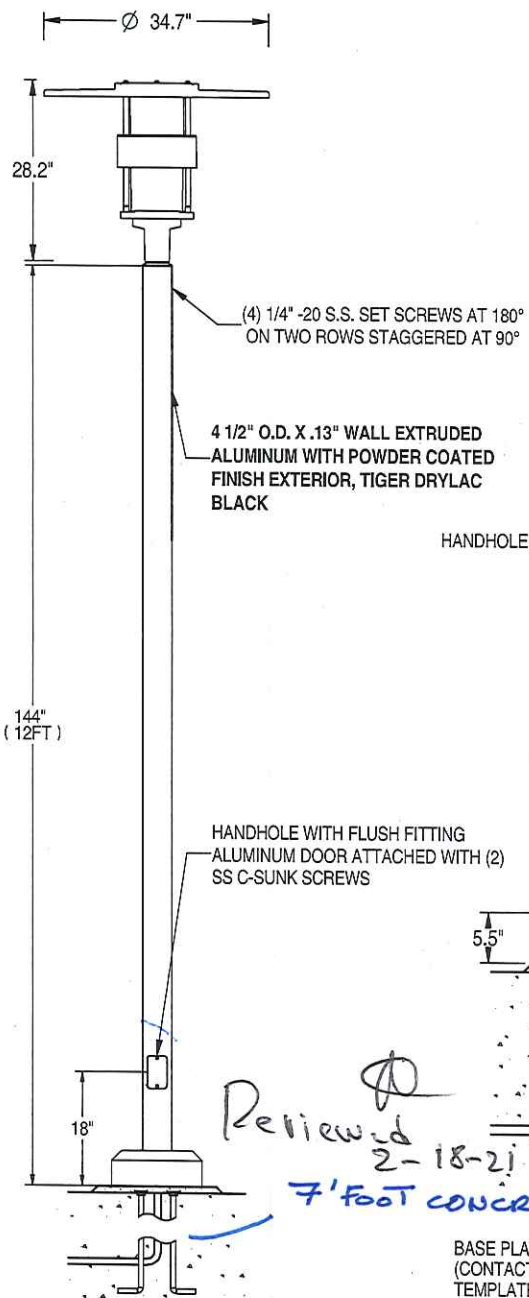

**WINDLOAD: EPA 1.8 SQ. FT.
WEIGHT: 43 LBS**

*Reviewed 2-18-21
7' FOOT CONCRETE BASES FOR ALL POLES*

BASE PLATE DETAIL
(CONTACT FACTORY FOR FULL SIZE BOLT LOCATION TEMPLATE)

NOTES:
1. FINISH: AS NOTED
2. VOLTAGE: 120-277V

**SERIES 38 - SEE SPECS
POWDER COAT FINISH/ MARINE
GRADE AS PER NEW SPECS/REPORT**

LOUIS POULSEN MUST RECEIVE THIS DRAWING WITH APPROVAL SIGNATURE PRIOR TO THE DEVELOPMENT AND MATERIAL PURCHASE OF THIS ITEM. ANY MODIFICATION OF THIS DRAWING NOT DONE BY LOUIS POULSEN WILL INVALIDATE THE QUOTATION. DELAYS IN PROVIDING DRAWING APPROVAL WILL IMPACT DELIVERY TIMELINE.

louis poulsen <small>LOUIS POULSEN USA, INC. 3280 MERIDIAN PKWY FT LAUDERDALE FL 33331 PHONE: (954) 349 2525 FAX: (954) 349 2550</small>	JOB NAME: West Avenue 14th St, Miami Beach		
	TITLE: ALB-MAX-POST/71W LED/3000K/ 120-277V/ TIGER DRYLAC BLACK/ BUG-U3/ T-RSA-4.SIN/DIM 0-10V /12FT / MODIFIED TENON		
MOD. FROM: Std SAP	QUOTE NO.: 20074913		
DRAWN BY: arl.us	DATE: 11/9/2020	APPROVED BY:	TYPE:
MATERIAL: AS NOTED	VERSION: 01		
SCALE: NTS	SHEET: 1 OF 1	DWG. NO.: 131-20148-001	

POULSEN WARRANTY

10. Warranty

A. Louis Poulsen warrants for a period of five (5) years, unless otherwise stipulated, from date of invoice for the original purchase that its products are free from defects in materials and workmanship. EXCEPT FOR THE EXPRESS WARRANTY ABOVE, LOUIS POULSEN MAKES NO REPRESENTATIONS AND GRANTS NO WARRANTIES, EXPRESS OR IMPLIED, BY STATUTE OR OTHERWISE, AND DISCLAIMS ALL OTHER WARRANTIES, WRITTEN OR VERBAL, EXPRESS OR IMPLIED, INCLUDING ANY WARRANTY OF QUALITY, MERCHANTABILITY OR FITNESS FOR A PARTICULAR USE OR PURPOSE. THIS WARRANTY IS THE EXCLUSIVE WARRANTY GIVEN BY LOUIS POULSEN FOR ITS PRODUCTS AND CAN ONLY BE AMENDED IN WRITING BY LOUIS POULSEN'S PRESIDENT.

B. Every claim under this warranty shall be deemed waived unless received in writing by Louis Poulsen within 30 days of the date the purported defect to which each related claim is discovered, or should have been discovered. It is the buyer's responsibility to file all claims directly with Louis Poulsen's Home Office. Claims may not be filed through Louis Poulsen's field representatives. All Claims must comply with Louis Poulsen's Warranty policy unless amended as noted above.

C. Ballasts and drivers are covered by a separate manufacturers' warranty.

D. The guarantee conditions apply exclusively to the mortality exceeding the nominal failure rate (0.2% per 1000 burning hours). With LED modules, a reduction in luminous flux is normal as long as the relevant value does not fall below 0.6%/1000h burning hours and is thus not covered by the guarantee. Due to technical progress and to the change in the luminous flux of products that is caused by their use, subsequent deliveries of LED light sources may have light properties deviating from those of the original products.

E. The warranty does not apply to: Acts of nature such as but not limited to damage caused by lightning. Damage caused by electrical supply conditions, including spikes over/under voltage and ripple current control systems that are outside normal operating conditions. The fixture has no additional surge protection to the originated protection from the driver. This protection can vary from product to product.

For information on protection level or information on additional protection please contact Louis Poulsen.



lightworks
Smart Technologies. **Bright** Solutions.

ROADWAY POLE WINDLOADING CALCULATIONS AND FOUNDATION DESIGN

MIAMI BEACH PUBLIC WORKS DEPARTMENT
2016 – 090-KB WEST AVE PHASE II IMPROVEMENTS
SOUTH OF 14TH STREET

25'-0" FLOODLIGHT POLE ASSEMBLY
STANDARD FOOTING MOUNT
FLAGPOLES / P&K DWG. 16348

170 MPH DESIGN WIND SPEED
300 YEAR MEAN RECURRENCE INTERVAL
2015 AASHTO LRFD SPECIFICATION
AND THE
FDOT FY 2019-20 INDEX DESIGN STANDARDS
INDEX 715-002

Submitted by:

Flagpoles, Inc.
P&K Tubular Products, Inc.
December 31, 2019



Sheets 1-7
Dennis M. Patrick, P.E.
3828 Bowfin Trail Kissimmee, FL 34746
FL PE 40465 407-350-5373

MIAMI BEACH PUBLIC WORKS DEPARTMENT
2016 – 090-KB WEST AVE PHASE II IMPROVEMENTS
SOUTH OF 14TH STREET

25'-0" FLOODLIGHT POLE ASSEMBLY
STANDARD FOOTING MOUNT
FLAGPOLES / P&K DWG. 16348

170 MPH DESIGN WIND SPEED
300 YEAR MEAN RECURRENCE INTERVAL
2015 AASHTO LRFD SPECIFICATION
AND THE
FDOT FY 2019-20 INDEX DESIGN STANDARDS
INDEX 715-002

Submitted by:

Flagpoles, Inc.
P&K Tubular Products, Inc.
December 31, 2019

FLOODLIGHT POLE DESIGN ---- 2015 AASHTO LRFD SPECIFICATION

DESIGN BASIC WIND SPEED: 170 MPH
 MEAN RECURRENCE INTERVAL: 300 YEAR
 PERMANENT LOAD FACTOR: 1.1 TABLE 3.4-1
 WIND LOAD FACTOR: 1.0 - TABLE 3.4-1

LOAD COMBINATION LIMIT STATE: EXTREME I
 WIND LOAD CASE 1

LIGHTING POLE: 8.000 IN. X .188 IN. WALL X 24.417 FT. ---- TAPERED: 8.000 IN. X 4.500 IN.
 6063-T6 ALUMINUM ALLOY --- HEAT TREATED AFTER WELDING
 AREA, A = 4.602 IN² SECTION MODULUS, Z = 8.783 IN³
 MOMENT OF INERTIA - BOTTOM, I_B = 35.130 IN⁴ MOMENT OF INERTIA - TOP, I_T = 5.917 IN⁴
 SHOE BASE TYPE: 8-1992
 CHECK OF POLE AT SHOE BASE

POLE WIND SHEAR LOAD = 433.574 LBS.
 POLE VERTICAL WIND SHEAR LOAD CENTROID = 12.318 FT. FROM BOTTOM OF SHOE BASE
 POLE WEIGHT = 101.835 LBS.

			X CENTROID FROM POLE CENTERLINE (FT.)		Y CENTROID
			WEIGHT	WIND	
LUMINAIRE	EPA = 0.97 SQ. FT.	WT. = 38.00 LBS.	7.000 FT.	7.000 FT.	27.000 FT. FROM GRADE
6'-0" DEC. ARM	EPA = 3.60 SQ. FT.	WT. = 25.00 LBS.	3.000 FT.	3.000 FT.	26.000 FT. FROM GRADE

SHEAR LOAD ---- DUE TO WIND

POLE SHEAR = 433.574 LBS.
 LUMINAIRE SHEAR = 0.97 X 73.984 X 1.14 X 0.850 X 0.961 = 66.807 LBS.
 6'-0" DEC. ARM SHEAR = 3.60 X 73.984 X 1.14 X 0.850 X 0.953 = 245.982 LBS.
V = 746.363 LBS.

TORSION MOMENT ---- DUE TO WIND

LUMINAIRE MOMENT = 0.97 X 73.984 X 1.14 X 0.850 X 0.961 X 7.000 X 12 = 5611.806 IN-LBS
 6'-0" DEC. ARM MOMENT = 3.60 X 73.984 X 1.14 X 0.850 X 0.953 X 3.000 X 12 = 8855.355 IN-LBS
T = 14467.161 IN-LBS

OVERTURNING MOMENT ---- DUE TO WIND

POLE MOMENT = 433.574 X 12.318 X 12 = 64091.233 IN-LBS
 LUMINAIRE MOMENT = 0.97 X 73.984 X 1.14 X 0.850 X 0.961 X 27.000 X 12 = 21645.536 IN-LBS
 6'-0" DEC. ARM MOMENT = 3.60 X 73.984 X 1.14 X 0.850 X 0.953 X 26.000 X 12 = 76746.410 IN-LBS
OTM = 162483.179 IN-LBS

PERMANENT LOAD MOMENT ---- DUE TO WEIGHT

LUMINAIRE MOMENT = 38.000 X 7.000 X 1.1 X 12 = 3511.200 IN-LBS
 6'-0" DEC. ARM MOMENT = 25.000 X 3.000 X 1.1 X 12 = 990.000 IN-LBS
PLM = 4501.200 IN-LBS

RESULTANT BENDING MOMENT, M = SQ. RT. [(OTM)² + (PLM)²]

$$M = \text{SQ. RT.} [(162483.179)^2 + (4501.200)^2] = 162545.514 \text{ IN-LBS}$$

AXIAL LOAD ---- DUE TO DEAD LOAD

POLE AXIAL = 101.835 X 1.1 = 112.019 LBS.
 LUMINAIRE AXIAL = 38.000 X 1.1 = 41.800 LBS.
 6'-0" DEC. ARM AXIAL = 25.000 X 1.1 = 27.500 LBS.
P = 181.319 LBS.

POLE WIND RESULTANT SHEAR STRESS

$$\text{RESULTANT SHEAR STRESS, } f_v = (2 \times \text{RESULTANT SHEAR, } V) / \text{AREA, } A$$

$$\text{RESULTANT SHEAR STRESS, } f_v = (2 \times 746.363) / 4.602 = 324.369 \text{ PSI}$$

POLE WIND TORSION SHEAR STRESS

$$\text{TORSION SHEAR STRESS, } f_t = \text{TORSION MOMENT, } T / (2 \times \text{SECTION MODULUS, } Z)$$

$$\text{TORSION SHEAR STRESS, } f_t = 14467.161 / 17.565 = 823.630 \text{ PSI}$$

POLE RESULTANT BENDING STRESS

$$\text{RESULTANT BENDING STRESS, } f_b = \text{RESULTANT MOMENT, } M / \text{SECTION MODULUS, } Z$$

$$\text{RESULTANT BENDING STRESS, } f_b = 162545.514 / 8.783 = 18507.751 \text{ PSI}$$

PERMANENT LOAD AXIAL STRESS

$$\text{DEAD LOAD AXIAL STRESS, } f_a = \text{AXIAL LOAD, } P / \text{AREA, } A$$

$$\text{DEAD LOAD AXIAL STRESS, } f_a = 181.319 / 4.602 = 39.401 \text{ PSI}$$

MEMBER SHEAR FACTORED DESIGN STRESS, ΦF_S $\Phi_V = 0.90$ Eq. 6.5.1-37

$$\Lambda = 2.9 \times (R_b / t)^{.625} \times (L_v / R_b)^{.25}$$

$$\Lambda = 2.9 \times (3.906 / 0.188)^{.625} \times (293.004 / 3.906)^{.250} = 56.938$$

$$F_{SY} = 0.60 \times F_{TY} = 0.60 \times 25 = 15 \text{ KSI}$$

$$B_S = F_{SY} \times [1 + (F_{SY} / 800)^{0.333}] = 15 \times [1 + (15 / 800)^{0.333}] = 18.990$$

$$D_S = B_S / 10 \times (B_S / E)^{0.5} = (18.990 / 10) \times (18.990 / 10100)^{0.5} = 0.082$$

$$C_S = 0.41 \times (B_S / D_S) = 0.41 \times (18.990 / 0.082) = 94.554$$

$$\Lambda_1 = [(1.3 \times B_S) - F_{SY}] / (1.63 \times D_S) = [(1.3 \times 18.990) - 15] / (1.63 \times 0.082) = 72.174$$

$$\Lambda_2 = C_S / 1.25 = 75.643$$

$$\Phi F_S = \Phi_V \times F_{SY} \times 0.85 \quad \Lambda \leq \Lambda_1$$

$$\Phi F_S = 0.90 \times 15 \times 1000 \times 0.85 = 11475 \text{ PSI}$$

$$\Phi F_S = \Phi_V \times [(1.3 \times B_S) - (1.63 \times D_S \times \Lambda)] \times 0.85 \quad \Lambda_1 < \Lambda < \Lambda_2$$

$$\Phi F_S = 0.90 \times [(1.30 \times 18.990) - (1.63 \times 0.082 \times 56.938)] \times 1000 \times 0.85 = 13039 \text{ PSI}$$

$$\Phi F_S = \Phi_V \times [(\pi^2 \times E) / (1.25 \times \Lambda)^2] \times 0.85 \quad \Lambda \geq \Lambda_2$$

$$\Phi F_S = 0.90 \times [(3.14159^2 \times 10,100) / (1.25 \times 56.938)^2] \times 1000 \times 0.85 = 19571 \text{ PSI}$$

MEMBER TORSION FACTORED DESIGN STRESS, ΦF_T $\Phi_T = 0.90$ Eq. 6.5.1-44

$$\Lambda = 2.9 \times (R_b / t)^{.625} \times (L_v / R_b)^{.25}$$

$$\Lambda = 2.9 \times (3.906 / 0.188)^{.625} \times (293.004 / 3.906)^{.250} = 56.938$$

VALUES FOR B_S , D_S AND C_S SAME AS CALCULATED IN MEMBER SHEAR FACTORED DESIGN STRESS

$$\Lambda_1 = (B_S - F_{SY}) / (1.25 \times D_S) = (18.990 - 15) / (1.25 \times 0.082) = 38.766$$

$$\Lambda_2 = C_S / 1.25 = 75.643$$

$$\Phi F_T = \Phi_T \times F_{SY} \times 0.85 \quad \Lambda \leq \Lambda_1$$

$$\Phi F_T = 0.90 \times 15 \times 1000 \times 0.85 = 11475 \text{ PSI}$$

$$\Phi F_T = \Phi_T \times [B_S / (1.25 \times D_S \times \Lambda)] \times 0.85 \quad \Lambda_1 < \Lambda < \Lambda_2$$

$$\Phi F_T = 0.90 \times [(18.990 - (1.25 \times 0.082 \times 56.938))] \times 1000 \times 0.85 = 10044 \text{ PSI}$$

$$\Phi F_T = \Phi_T \times [(\pi^2 \times E) / (1.25 \times \Lambda)^2] \times 0.85 \quad \Lambda \geq \Lambda_2$$

$$\Phi F_T = 0.90 \times [(3.14159^2 \times 10,100) / (1.25 \times 56.938)^2] \times 1000 \times 0.85 = 15054 \text{ PSI}$$

MEMBER AXIAL COMPRESSION FACTORED DESIGN STRESS, ΦF_C $\Phi_C = 0.90$ Eq. 6.5.1-11

$$\Lambda = (k \times L) / r = (2 \times 293.004) / 2.144 = 273.262$$

CALCULATION OF SLENDERNESS LIMIT, C_c

$$B_c = F_{cy} \times [1 + (F_{cy}/2250)^{0.5}] = 25 \times [1 + (25/2250)^{0.5}] = 27.635$$

$$D_c = B_c/10 \times (B_c/E)^{0.5} = 27.635/10 \times [27.635/10100]^{0.5} = 0.145$$

$$C_c = \Lambda_2 = 0.41 \times (B_c/D_c) = 0.41 \times (27.635/0.145) = 78.381$$

$$\Phi F_c = \Phi_c \times [(0.85 \times (B_c - (D_c \times \Lambda)) \times 0.85] \quad \Lambda < \Lambda_2$$

$$\Phi F_c = 0.90 \times [(0.85 \times (27.635 - (0.145 \times 273.26)) \times 1000 \times 0.85] = 7716 \text{ PSI}$$

$$\Phi F_c = \Phi_c \times [0.85 \times (\pi^2 \times E) / \Lambda^2] \times 0.85 \quad \Lambda \geq \Lambda_2$$

$$\Phi F_c = 0.90 \times [0.85 \times 3.14159^2 \times 10,100 / 273.262^2] \times 1000 \times 0.85 = 868 \text{ PSI}$$

MEMBER FLEXURAL COMPRESSION FACTORED DESIGN STRESS, ΦF_b

$$\Phi_b = 0.90$$

Eq. 6.5.1-20

$$\Phi F_b = \Phi_b \times 1.17 \times F_{cy} \times 0.85$$

$$\Phi F_b = 0.90 \times 1.17 \times 25 \times 1000 \times 0.85 = 22376 \text{ PSI}$$

CALCULATION OF BENDING LOAD EFFECT COEFFICIENT OF AMPLIFICATION, B_2

$$1.414 \times \pi \times (E/F_y) \leq (k \times L) / r$$

$$1.414 \times 3.14159 \times [(10100/25)^{0.5}] \leq [(2 \times 293.004) / 2.144]$$

$$89.2874 \leq 273.2619 \quad \text{MEETS CONDITION}$$

$$P_{\text{EQUIVALENT}} = (P_T \times (I_B/I_T)^{0.333}) + (0.38 \times D_P)$$

$$P_{\text{EQUIVALENT}} = [(0.069 \times (35.130/5.917)^{0.333}] + (0.38 \times 0.112) = 0.168 \text{ KIPS}$$

$$P_{\text{EULER BOTTOM}} = (\pi^2 \times E \times I_B) / (k \times L)^2$$

$$P_{\text{EULER BOTTOM}} = (3.14159^2 \times 10100 \times 35.130) / (2 \times 293.004)^2 = 10.198 \text{ KIPS}$$

$$\text{COEFFICIENT OF AMPLIFICATION, } B_2 = 1 / [1 - (P_{\text{EQUIVALENT}}/P_{\text{EULER BOTTOM}})] \geq 1.000$$

$$\text{COEFFICIENT OF AMPLIFICATION, } B_2 = 1 / [1 - (0.168/10.198)]$$

$$\text{COEFFICIENT OF AMPLIFICATION, } B_2 = 1.017$$

$$\text{DESIGN STRESS RATIO} = f_c / (\Phi_c F_c) + [B_2 \times [f_b / (\Phi_b F_b)]] + [f_s / (\Phi_s F_s) + f_t / (\Phi_t F_t)]^2 \leq 1.000$$

$$\text{AXIAL COMPONENT} = f_c / (\Phi_c F_c) = 39.401 / 868 = 0.045$$

$$\text{FLEXURAL COMPONENT} = B_2 \times [f_b / (\Phi_b F_b)] = 1.017 \times (18507.751 / 22376) = 0.841$$

$$\text{SHEAR COMPONENT} = f_s / (\Phi_s F_s) = 324.369 / 11475 = 0.028$$

$$\text{TORSION COMPONENT} = f_t / (\Phi_t F_t) = 823.630 / 10044 = 0.082$$

$$\text{DSR} = 0.045 + 0.841 + (0.028 + 0.082)^2$$

$$\text{DSR} = 0.899 \quad \text{*** POLE SIZE MEETS SPECIFICATION ***}$$

BASE WELD STRESS CALCULATION

LIGHTING POLE: 8.000 IN. X 0.188 IN. WALL
 POLE BASE TYPE: 8-1992

SHOE BASE TOP WELD = 0.250 IN.
 SHOE BASE BOTTOM WELD = 0.188 IN.

WIND SHEAR LOAD, V = 746.363 LBS.
 TORSION MOMENT, T = 14467.161 IN-LBS
 RESULTANT BENDING MOMENT, M = 162545.514 IN-LBS
 AXIAL LOAD, P = 181.319 LBS.

TOP WELD TROAT, T2 = 0.177 IN.
 TOP WELD CENTER DIA = 8.125 IN.
 TOP WELD EFFECTIVE LENGTH = 25.525 IN.

BOTTOM WELD TROAT, T2 = 0.133 IN.
 BOTTOM WELD CENTER DIA., D2 = 7.906 IN.
 BOTTOM WELD EFFECTIVE LENGTH = 24.838 IN.

RESOLVING RESULTANT MOMENT, M AND TORSION MOMENT, T INTO COUPLES

P_{RM} = RESULTANT BENDING MOMENT, M / POLE RADIUS

$$P_{RM} = 162545.514 / (2 \times 4.00) = 20318.189 \text{ LBS.}$$

V_T = TORSION MOMENT, T / POLE RADIUS

$$V_T = 14467.161 / (2 \times 4.00) = 1808.395 \text{ LBS.}$$

RESULTANT BASE WELD LOAD, P_r = SQ. RT. [$(P_{RM} + P)^2 + (V_T + V)^2$]

$$P_r = \text{SQ. RT.} [(20318.189 + 181.319)^2 + (1808.395 + 746.363)^2] = 20658.089 \text{ LBS.}$$

WELD FACTORED RESISTANCE, $\Phi R_n = \Phi \times (F_{sw} \times \text{AVERAGE WELD EFFECTIVE LENGTH, } L_{we})$

$$\Phi = 0.75$$

F_{sw} = FILLER METAL SHEAR STRENGTH, F_{su} X AVERAGE EFFECTIVE THROAT DEPTH

$$F_{sw} = 11500 \times [(0.177 + 0.133) / 2] = 1779 \text{ PSI}$$

F_{sw} = WELD-AFFECTED BASE METAL TENSILE STRENGTH, F_{ty} X AVERAGE WELD SIZE

$$F_{sw} = 25000 \times [(0.250 + 0.188) / 2] = 5469 \text{ PSI}$$

USE LOWER VALUE OF $F_{sw} = 1779 \text{ PSI}$

WELD FACTORED RESISTANCE, $\Phi R_n = 0.75 \times 1779 \times [(25.525 + 24.838) / 2] = 33595 \text{ LBS.}$

*** WELD SIZES MEET SPECIFICATION ***

ANCHOR BOLT DESIGN - ON SQUARE PATTERN (REF. ANSI / AISC 360-16)

ANCHOR BOLTS: 1.00 DIAMETER X 48.00 IN. LONG (8UNC THREADS PER INCH)

ANCHOR BOLTS ARE PER ASTM F1554 GRADE 55 STEEL WITH 75000 PSI MINIMUM TENSILE STRENGTH.

ANCHOR BOLTS ARE HOT-DIPPED GALVANIZED PER ASTM A153.

ANCHOR BOLT ROOT STRESS AREA, $A_r = 0.551 \text{ IN}^2$

ANCHOR BOLT TENSILE STRESS AREA, $A_t = 0.606 \text{ IN}^2$

ANCHOR BOLT NOMINAL AREA, $A_b = 0.785 \text{ IN}^2$

BENDING MOMENT AT TOP OF FOUNDATION = 162545.514 IN-LBS.

AXIAL COMPRESSIVE LOAD AT TOP OF FOUNDATION = 181.319 LBS.

TORSIONAL MOMENT AT TOP OF FOUNDATION = 14467.161 IN-LBS.

TRANSVERSE SHEAR LOAD AT TOP OF FOUNDATION = 746.363 LBS.

ANCHORAGE BOLT CIRCLE = 9.75 DIAMETER

BENDING OCCURS ABOUT THE CENTER AXIS OF THE BASE PLACING ONE SIDE OF THE ANCHOR BOLTS IN TENSION AND THE OTHER SIDE IN COMPRESSION.

BY SUMMATION OF MOMENTS ABOUT THE BASE CENTERLINE ONE CAN DETERMINE THE BOLT TENSILE/COMPRESSIVE LOAD DUE TO THE BENDING MOMENT.

ANCHOR BOLT LOAD DUE TO BENDING MOMENT, P(M):

$$P(M) = \text{BENDING MOMENT} / (4 \times \text{BOLT CIRCLE} / 2 \times \sin 45^\circ)$$

$$P(M) = 162545.514 / (4 \times 9.750 / 2 \times \sin 45^\circ) = 11788.450 \text{ LBS.}$$

ANCHOR BOLT LOAD DUE TO AXIAL COMPRESSIVE LOAD, P(A):

$$P(A) = \text{AXIAL COMPRESSIVE LOAD} / 4$$

$$P(A) = 181.319 / 4 = 45.330 \text{ LBS.}$$

TOTAL ANCHOR BOLT TENSILE/COMPRESSIVE LOAD, P(TC)

$$P(TC) = P(M) + P(A) = 11788.450 + 45.330 = 11833.779 \text{ LBS.}$$

ANCHOR BOLT TORSIONAL SHEAR LOAD, V(T)

$$V(T) = \text{TORSIONAL MOMENT} / (4 \times \text{BOLT CIRCLE} / 2)$$

$$V(T) = 14467.161 / (4 \times 9.750 / 2) = 741.906 \text{ LBS.}$$

ANCHOR BOLT TRANSVERSE SHEAR LOAD, V(W)

$$V(W) = (2 \times \text{TRANSVERSE SHEAR}) / 4$$

$$V(W) = (2 \times 746.363) / 4 = 373.182 \text{ LBS.}$$

TOTAL ANCHOR BOLT SHEAR LOAD, V:

$$V = V(T) + V(W) = 741.906 + 373.182 = 1115.087 \text{ LBS.}$$

BOLT TENSILE/COMPRESSIVE STRESS, $f(t) = P(TC) / A_t = 11833.779 / 0.606 = 19536 \text{ PSI}$

BOLT TRANSVERSE SHEAR STRESS, $f(v) = V / A_r = 1115.087 / 0.551 = 2024 \text{ PSI}$

ANCHOR BOLT TENSILE FACTORED DESIGN STRESS, ΦR_n $\Phi = 0.75$ Eq. J3-1

$$F_n = 0.75 \times F_{tu} = 0.75 \times 75000 = 56250 \text{ PSI}$$

$$\Phi R_n = \Phi \times F_{tu} \times A_b$$

$$\Phi R_n = 0.75 \times 75000 \times 0.785 = 44179 \text{ PSI}$$

TENSILE BOLT LOAD PERCENTAGE = $(19536 / 44179) \times 100 = 44.22\%$

ANCHOR BOLT SHEAR FACTORED DESIGN STRESS, ΦR_n $\Phi = 0.75$ Eq. J3-1

$$F_n = 0.45 \times F_{tu} = 0.45 \times 75000 = 33750 \text{ PSI}$$

$$\Phi R_n = \Phi \times F_n \times A_b$$

$$\Phi R_n = 0.75 \times 33750 \times 0.785 = 19880 \text{ PSI}$$

SHEAR BOLT LOAD PERCENTAGE = $(2024 / 19880) \times 100 = 10.18\%$

CHECK OF ANCHOR BOLT PULLOUT STRENGTH - PER ACI 318-11

ANCHOR BOLT TENSILE PULLOUT LOAD, P(M) = 11788.450 LBS.

CONCRETE COMPRESSIVE STRENGTH, f'(c) = 3400 PSI

ANCHOR BOLT DIAMETER (ROLLED THREAD) = 0.910 IN.

BOLT HEX NUT BEARING AREA = 1.501 IN²

PULLOUT STRENGTH IN TENSION, N_{pn} ASSUME CONCRETE IS CRACKED, $\Psi_{c,P} = 1.00$

$N_{pn} = \Psi_{c,p} \times N_p$ ACI 318-11 D.5.3.1

$N_p = 8 \times A(\text{brg}) \times f'(c)$ ACI 318-11 D.5.3.4

$N_p = 8 \times 1.501 \times 3400 = 40827$ LBS.

$N_{pn} = 1.00 \times 40827 = 40827$ LBS.

PULLOUT STRENGTH IN TENSION, N_{pn} > ANCHOR BOLT TENSILE PULLOUT LOAD, P(M)

***** ANCHOR BOLT MEETS ACI 318--11 PULLOUT REQUIREMENT *****

POLE TOP ROTATION DUE TO SERVICE I PERMANENT LOAD

LIGHTING POLE: 8.000 IN. X .188 IN. WALL X 24.417 FT. ----- TAPERED: 8.000 IN. X 4.500 IN.
 6063-T6 ALUMINUM ALLOY --- HEAT TREATED AFTER WELDING
 MODULUS OF ELASTICITY, E = 10,000,000 PSI

POLE TAPER PROFILE:

POLE TOP STRAIGHT LENGTH = 4.000 FT.

POLE MID-SECTION TAPER LENGTH = 17.000 FT. TAPER RATE = 0.206 IN/FT

POLE BOTTOM STRAIGHT LENGTH = 3.417 FT.

PERMANENT LOAD MOMENT, PLM = 4501.200 IN-LBS.

PERMANENT LOAD FACTOR: 1.1 TABLE 3.4-1

SERVICE LOAD I FACTOR: 1.0 TABLE 3.4-1

SERVICE LOAD I MOMENT, M = 4501.200 X 1.0 / 1.1 = 4092.000 IN-LBS.

DEAD LOAD MOMENT APPLIED AT 24.417 FT. FROM BASE OF POLE

ROTATION = (DLM x L) / (E x I)

SECTION NO.	SEGMENT LENGTH (IN.)	AVERAGE SEGMENT O.D. (IN.)	MOMENT OF INERTIA, I (IN ⁴)	SEGMENT ROTATION (RADIAN)
TOP STRAIGHT SECTION:		NO. OF SEGMENTS = 4		
1	12.000	4.500	5.917	0.00083
2	12.000	4.500	5.917	0.00083
3	12.000	4.500	5.917	0.00083
4	12.000	4.500	5.917	0.00083
MID-SECTION TAPERED SECTION:		NO. OF SEGMENTS = 17		
1	12.000	4.603	6.350	0.00077
2	12.000	4.809	7.279	0.00067
3	12.000	5.015	8.295	0.00059
4	12.000	5.221	9.401	0.00052
5	12.000	5.426	10.601	0.00046
6	12.000	5.632	11.900	0.00041
7	12.000	5.838	13.300	0.00037
8	12.000	6.044	14.806	0.00033
9	12.000	6.250	16.422	0.00030
10	12.000	6.456	18.152	0.00027
11	12.000	6.662	19.998	0.00025
12	12.000	6.868	21.967	0.00022
13	12.000	7.074	24.060	0.00020
14	12.000	7.279	26.282	0.00019
15	12.000	7.485	28.637	0.00017
16	12.000	7.691	31.128	0.00016
17	12.000	7.897	33.760	0.00015
BOTTOM STRAIGHT SECTION:		NO. OF SEGMENTS = 4		
1	10.251	8.000	35.130	0.00012
2	10.251	8.000	35.130	0.00012
3	10.251	8.000	35.130	0.00012
4	10.251	8.000	35.130	0.00012
TOTAL ROTATION =				0.00984

TOTAL POLE TOP ROTATION = 0.0098 RADIAN = 0.564°

AASHTO ALLOWABLE POLE TOP ROTATION = 0.0291 RADIAN = 1.667°

Article 10.4.2.1

- STRESSCRETE GROUP
ORNAMENTAL LIGHTING ARM, HUB & SCROLL
PER DWG. # 206A9835-4B
NOT INCLUDED
- STERNBERG LIGHTING FIXTURE
PER DWG. # SC23702-6
NOT INCLUDED

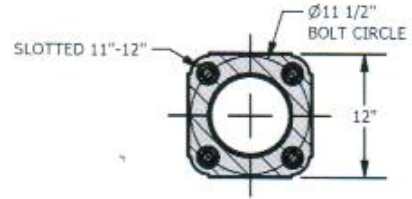
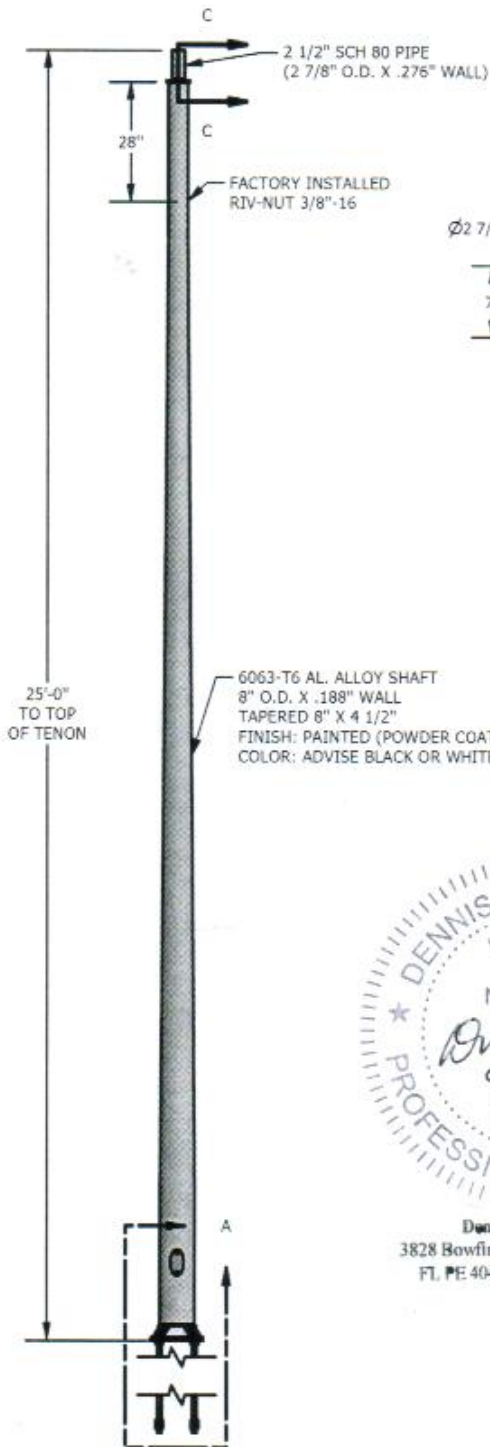

SECTION B-B
SCALE 0.06 : 1

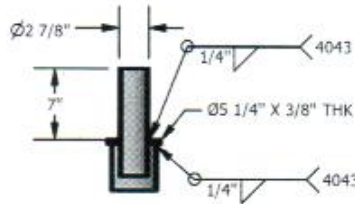

SECTION C-C
SCALE 0.06 : 1

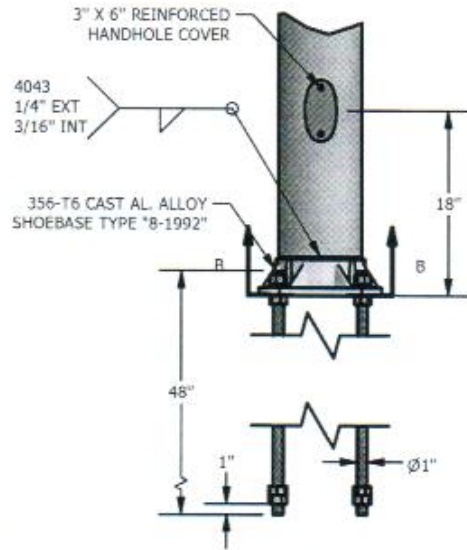

DETAIL A
SCALE 0.06 : 1



Dennis M. Patrick, P.E.
3828 Bowfin Trail Kissimmee, FL 34746
FL PE 40465 407-350-5373

ANCHOR BOLTS PER ASTM F1554GR55, FULLY GALVANIZED PER ASTM A153 WITH ALL NUTS, FLATWASHERS, AND LOCKWASHERS

 95 GNARLED HOLLOW RD.
 EAST SETAUKET, N.Y. 11733

PROJECT: MIAMI BEACH, PWD		DIST:
CONTRACTOR:		AGENT: LIGHTWORKS
DRAWN BY: RM	DATE: 12/23/2019	MATERIAL: AS NOTED
CHK'D BY: SAF	APP'D:	DRAWING #:
SCALE: AS NOTED	WORK ORDER #: 57560	16348

REVISION HISTORY		
REV	DESCRIPTION	DATE
-	INITIAL RELEASE	12/23/2019

**FOUNDATION DESIGN CALCULATIONS
OF 25' ALUMINUM LIGHTING POLE WITH 6' ARM
FLAGPOLES DRAWING 16348**

**PROJECT: WEST AVE IMPROVEMENTS
SOUTH OF 14TH ST
MIAMI-DADE COUNTY, FLORIDA**

**DESIGN CRITERIA: 2015 AASHTO LRFD
WIND SPEED: 170 MPH
300 YEAR INTERVAL**

September 9, 2020, R-1
December 31, 2019

Prepared By:
Dennis M. Patrick, PE
3828 Bowfin Trail
Kissimmee, FL 34746
484-252-1167
FL PE #40465

Submitted By:
LIGHTWORKS, INC
7035A SW 47th Street
Suite A
Miami, FL 33155
305-456-3520



FOUNDATION DESIGN OF 25' M.H. ALUMINUM POLE
West Avenue Improvements, Miami-Dade County

R-1 9/9/2020
 12/31/2019
 Sheet 1/3

General Data

	Reference Flagpoles Design Calculations dated 12/18/19	
Luminaire C.G. Height (ft)	27	
Number of Luminaire	1	Mounted on Sternberg ornamental arm
Area of Fixture (ft ²) = EPA	0.97	
Weight of Fixture (lb) = DL	38.0	
Area of 6' Arm (ft ²) = EPA	3.60	
Weight of Arm (lb) = DL	25.0	
Wind Speed (mph)	170	2015 AASHTO LRFD
Design Interval	300	
Gust Effect Factor	1.14	

Pole Data from Flagpoles calculations dated 12/31/19 and Pole drawing 16348

Size	8.0" x 4.5" x 0.188" x 25'-0" with 6' Ornamental arm		
Base Diameter (in) / Top Diameter (in)	8.0	4.5	6.3
Shaft Length (ft)	25.0		
Anchor Bolts	1" Diameter x 48" long		
Bolt Circle	9.75		

Summary of Lighting Pole Base Reactions at 170 mph

Longitudinal Shear	746.3 lbs
Transverse Shear	149.2 lbs
Longitudinal Moment	13540.3 ft-lbs
Transverse Moment	375.0 ft-lbs
Axial	181.30 lbs
Torsion	1205.00 ft-lbs

Note: The design of the light pole, anchor bolts and fixture are by others



FOUNDATION DESIGN OF 25' M.H. ROUND NON-TAPERED POLE

Project: West Avenue Improvements, Miami-Dade County

Sheet 2/3

References

- 1.) Flagpoles 25" M.H. Aluminum Pole with ornamental Arm
at a wind speed of 170 mph per 2015 AASHTO design criteria.
- 2.) Flagpoles pole drawing 16348 for anchor bolt size and bolt circle

SOIL DATA

Eff. Unit weight, $S_b = 0.060$ k/cu. ft.
 $K_p = 3.0$

Angle of friction 30 degrees

Soil assumption

Cohesionless sand
 Saturated wt = 60.0 pcf
 Water @ 0.0'

LATERAL RESISTANCE

Axial $A = 0.181$ k
 Moment $M_r = 13.545$ ft-k
 Shear $V_r = 0.746$ k
 Shaft Dia. $b = 2.00$ ft
 Length $L = 7.0$ ft
 Offset $e = 0.0$

Refer to Pole Analysis at 170 mph

Moment Ultimate = $(0.5)(\text{unit wt})(\text{Dia.})(L-e^3)(K_p) = 61.74$ ft-k

$H = \text{Moment} / \text{Shear} = 18.2$ ft

Moment applied at btm fdn. = $\text{Shear}(H+L) = 18.770$ ft-k

Factor of Safety = $\text{Mom. Ult.} / \text{Mom. @ btm} = 3.3 > 2.0$

Note: Use 24" diameter foundation
 R-1, Increased to 7' deep per City
 No Offset from top of foundation to grade

Design ok

USE: **2.00** Ft Dia. x **7.0** Feet long

A precast or drill shaft foundation can be used

Note: The design of the pole, anchor bolts and fixture are by others.



FOUNDATION REINFORCEMENT

Sheet 3/3

		English	
Concrete	$f_c =$	4,000	psi Minimum
Rebar	$F_y =$	60,000	psi
No.7 bars	$A_{bar} =$	0.60	in ²
Dia. Bar	$D_{bar} =$	1.000	inches
Shaft dia.	$b =$	24.0	inches

Design $A_{steel} = 0.01 A_{concrete}$

Bars reqd = $0.01 * (3.14 * b^2 / 4) / A_{bar} =$

Use: **8**
7.54

USE: 8-# 7 vertical bars equally spaced with 3" clear from edges of concrete with # 3 ties at 8" spacing.
Top and Bottom cover is 3"

ANCHOR BOLT EMBEDMENT

Bolt circle	BC =	9.75	inches	Refer to Pole drawing
Bolt dia.	AB =	1.00	inches	for bolt circle and anchor bolts
No. anchor bolts =		4		
F_y anchor bolt =		55,000	psi	
Bolt tension = Actual tension				16,665 lbs
Rebar Dia = $b - 6 - d_{bar} - 1 =$				16.000 inches
Gap = $b - 6 - BC - d_{bar} / 2 =$				3.625 inches
Bars reqd per bolt = Bars required / No. AB =				2.00 < 3
Bars per bolt = Bolt Ten. / $A_{bar} * (0.9 * F_y \text{ rebar})$				0.51
Area ratio = Bars per bolt / Bars req'd per bolt =				0.26
Dev. Lgth = $DL = 0.04 * (A_{bar} * F_y \text{ bar}) / (f_c)^{0.5} =$				22.77 inches
Bar Spacing = $BSp = 3.14 * \text{Rebar Dia.} / \text{No. Bars}$				6.28 inches
Spacing factor = $Sf =$				0.5
Add embed. = $((BSp * Sf)^2 + (Gap)^2)^{0.5}$				4.80 inches
Bolt embed = $(DL * \text{Area ratio}) + 6 + \text{Add. Embed} =$				16.65 inches
AASHTO Min. embedment = $20 * AB \text{ dia.} =$				20 inches

Use: 1" diameter x 48" total length with 2-HHN at bottom

Refer to pole mfg setting template for bolt circle, orientation and projection.





PRECAST
CONCRETE BASE
MIAMI BEACH STANDARD
LIGHTWORKS

STANDARD FOUNDATION FOR MIAMI BEACH

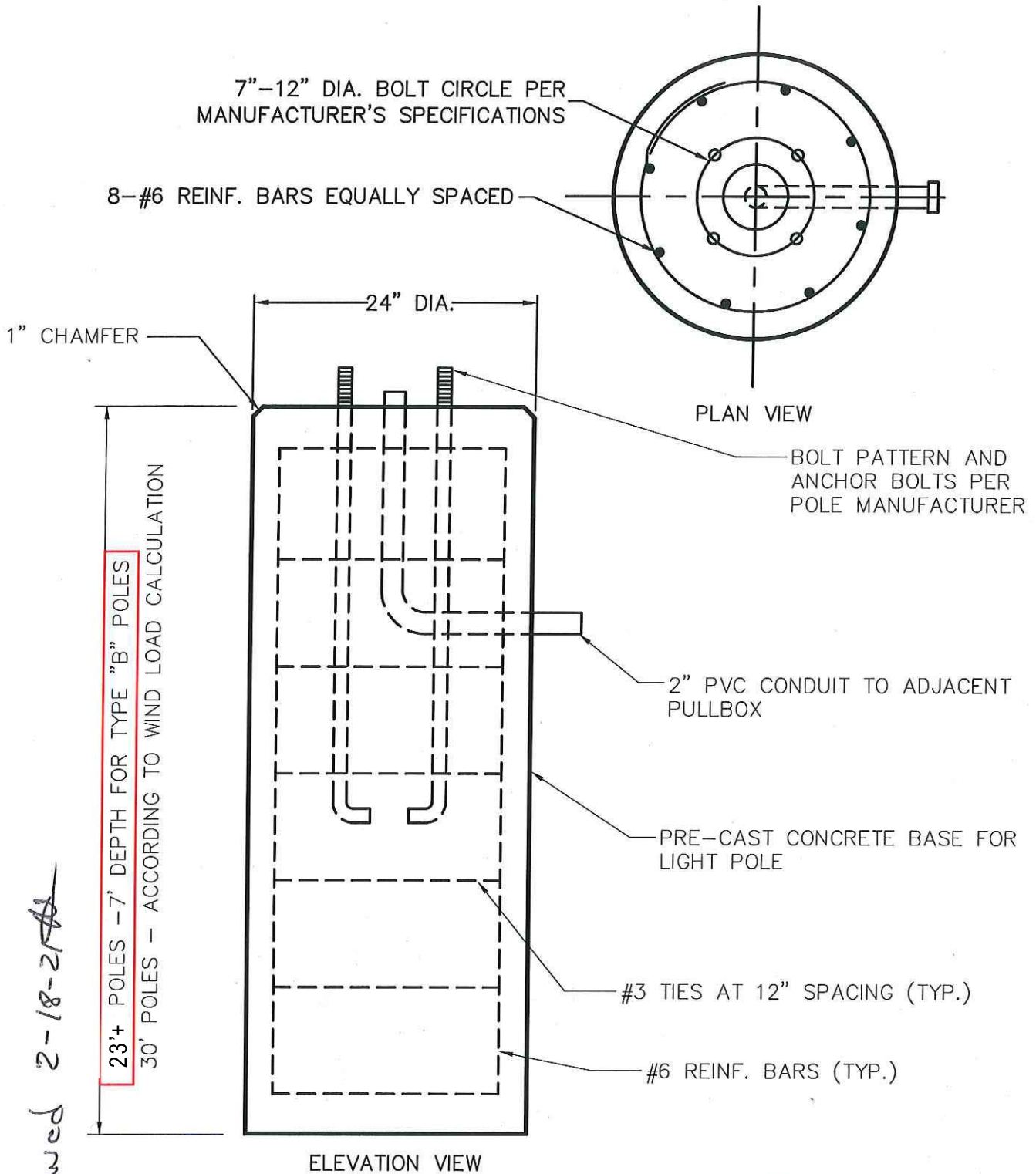

Reviewed 2-18-2018

CONCRETE POLE BASE DETAIL
N.T.S.



F:\WORK\BALLY\CAD-DWG\STANDARDS\CMB - STANDARD_DETAILS\Public Works Manual (2018)\CMB Street Light\STREET LIGHT DETAIL.dwg

MIAMI BEACH
PUBLIC WORKS DEPARTMENT
1700 CONVENTION CENTER DRIVE, MIAMI BEACH, FL 33139

APPROVED	REVISED	TITLE:
8/18/2015	12/04/2018	STREET LIGHT DETAILS
		CONCRETE POLE BASE DETAIL

STREET LIGHT DETAILS
CONCRETE POLE BASE DETAIL

STL3a



SERIES 38 MARINE GRADE PODER COAT / PAINT SPECS

NEW REQUIREMENT

- ROADWAY POLE
 - LUMINAIRE
 - ARM
- PEDESTRIAN LUMINAIRE AND POLE



SERIES 38 - super durable

POLYESTER TGIC SUPER DURABLE POWDER COATING COMPLIANT TO AAMA 2604 WITH EXCELLENT WEATHER RESISTANCE PROPERTIES FOR HIGH PERFORMANCE ARCHITECTURAL EXTERIOR APPLICATIONS

Typical applications

- metal façades
- steel constructions
- stadium seating and railings
- residential windows and doors
- patio furniture and garden equipment
- railings
- playground equipment
- agriculture equipment
- external ship components, communication towers, doors and railings
- military camouflage

Product details

Standard packaging in original 20 kg (44 lb) box and 2.5 kg (5 lb) minipack

Specific gravity (ASTM D792) approximately 1.2-1.8 g/cm³ depending on pigmentation

Theoretical coverage at 60 µm (2.5 mils) film thickness:
9.8 m²/kg (30.2 ft²/lb). Refer also to "Theoretic Powder Coating Coverage Chart" version 00-1000 (metric) version 00-1001 (imperial)

Storage stability 12 months at no more than 25 °C (77 °F) avoid direct and extended exposure to heat

Features

- excellent weather resistance
- excellent UV-light resistance
- AAMA 2604* compliant
- 5 years South Florida exposure
- very smooth flow
- good storage stability
- good yellowing stability

* AAMA 2604 compliance dependent upon the color and/or effect.

Finish

finish	gloss
smooth <i>glossy</i>	80-95+*
smooth <i>semi-gloss</i>	60±5*
smooth <i>matte</i>	20±5*

* Gloss level according to ASTM 523 at 60° angle (doesn't apply to metallic effect powder coatings). The measured gloss level of effect powder coatings can diverge from the details given in this Product Data Sheet. The creation of tolerance samples is recommended.

Available as stock-product in smooth glossy, semi-gloss and matte in 70 colors. It can be custom-matched in limited colors (minimum order quantity and color limitation apply).

Pretreatment

The following table reflects the common methods of pre-treatment with regards to various substrates and applications. In selecting the proper type of pretreatment, the suitability of the type of powder coating for a desired application according to the guidelines on this page should be observed.

	Aluminum			Galvanized Steel			Steel		
Degreasing	○			○					○
¹⁾ Chromating	○	○	○	○	○	○			
²⁾ Pre-Anodizing	○	○	○						
²⁾ Chrome free	○	○	○	○	○				
Iron Phosphating									○
Zinc Phosphating				○	○	○	○	○	○
Blasting							○	○	○
³⁾ Sweeping				○	○	○			
	I	E	A	I	E	A	S	I	E

Application: I = interior; E = exterior; A = architectural; S = steel

- 1) according to ASTM B 449
- 2) according to GSB quality and test regulations. The suitability of this type of pretreatment needs to be established through a boiling water test and subsequent cross-hatch adhesion and adhesive tape removal test
- 3) only for zinc coated parts >45 µm (>1.8 mils)
- 4) for a two-coat process/TIGER Shield

Processing

Corona and Tribostatic*

* For Tribostatic powder coatings, confirm before ordering. Suitability of metallic effects for Tribostatic processing must be verified prior to actual application. Please refer to the latest edition of the relevant application guidelines for metallic effect powder coatings.

Since not all powder coatings are suitable for recycling/reclaim, please verify before ordering.

Weather resistance

Florida exposure at 45° angle, facing south (RAL 8014)

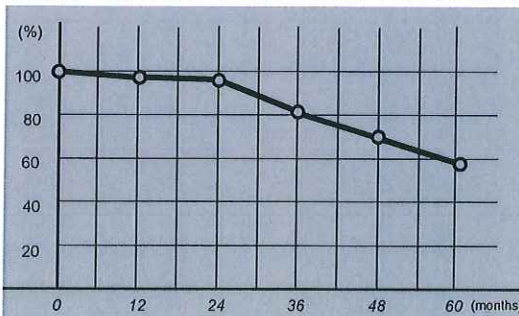

remaining gloss versus months

The remaining gloss values that can be expected may vary depending on the original gloss level and color. A reasonable degree of gloss loss and color variation owing to long term UV exposure should be expected.

Cure parameters

(substrate temperature versus curing time)

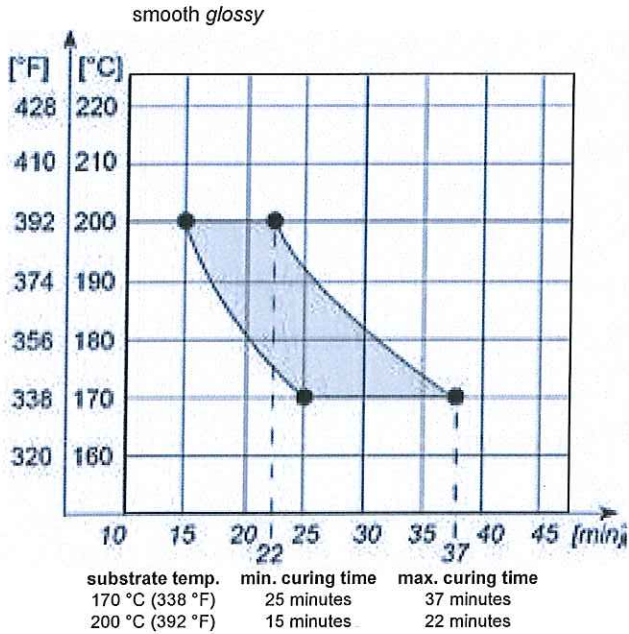

Cure parameters must be closely observed since mechanical properties will develop before full cross-linking.

Test results

Checked under laboratory conditions on 0.7 mm (1/64 inch) thick yellow chromated aluminum test panel. Actual product performance may vary due to product-specific properties such as gloss, color, effect and finish as well as application-related and environmental influences. When used as a two-coat system, the increase in film thickness will result in a decrease of mechanical properties.

test method	test	Series 38 smooth glossy
ISO 2360	recommended film thickness	60-80 µm (2.5-3.5 mils)
ASTM D523	gloss - 60°	80-95+
ASTM D3359 method B	cross cut tape test 1mm cutting distance	5B
ASTM D522	mandrel bending test cracking of coating	3 mm (1/8 inch)
ASTM D2794	ball impact test cracking of coating	up to 40 in.lb., cracking at the perimeter of the concave area but no cracking pick off
ASTM D3363	pencil hardness	2H minimum
ASTM D2247	determination of resistance to humidity 3,000 hours	maximum undercutting 1 mm (1/32 inch)
ASTM B117	5% salt spray solution 3,000 hours	maximum undercutting 1 mm (1/32 inch)
ASTM D2244	natural weathering in Florida 5 years	color change $\leq \Delta E$ 5.0 (Hunter)
ASTM D523	natural weathering in Florida 5 years	gloss retention >30%

Cleaning recommendations: refer to the latest edition of TIGER "Cleaning Recommendations" information sheet, Version 00-1005.

Special applications

Objects directly exposed to salt/fog conditions in a marine environment or need heavy corrosion protection must be coated with TIGER Shield system. Refer to the latest editions of TIGER Drylac® Product Data Sheets.

Please note

Top coating with a clear exterior grade powder coating over an interior grade powder coating does not result into a weather resistant coating system.

Post-bending properties of any part must be verified prior to application. Minor cracks in the coated surface may lead to corrosion.

Joint sealants and any other auxiliary products, such as glazing aids, gliding waxes, drilling and cutting lubricants, which come in contact with the coated surface, must be pH-neutral and free of substances that may damage the finish. Therefore, a suitability test at the applicator's end, prior to coating, is highly recommended.

In general, colors in the red, orange and yellow range may require an increased film thickness to achieve full hiding.

Any post-mechanical processing of already coated parts, such as sawing, drilling, milling, cutting and bending will result in damage of the coated surface and will subsequently weaken the corrosion protection.

Please read and understand the Safety Data Sheet (SDS) before use.

Chemical resistance

The required chemical resistance of a powder coating depends, among other things, on its formulation. Chemical resistance requirements must be considered according to processing conditions and final use of the finished product. This is best established during the product specification process. Agreement between all parties involved must be reached about the requirements for such chemical resistance as well as the test method, which may be performed in accordance with PCI test method #8 "Solvent Cure Test". Furthermore, the test duration and concentration of the test media need to be agreed upon.

Disclaimer

TIGER's verbal and written recommendations for the use of its products are based upon experience and in accordance with current technological standards. These are provided in order to support the buyer or user. They are non-committal and do not create any additional commitments to the purchase agreement. They do not release the buyer from verifying the suitability of TIGER products for the intended application. TIGER warrants that its products are free of flaws and defects to the extent stipulated in the Terms of Delivery and Payment.

As part of TIGER product information program, each Product Data Sheet is updated periodically. The latest version shall prevail. It is recommended to always check for the latest editions on TIGER's website download area www.tiger-coatings.com to make sure you have the most current version of this Product Data Sheet. The information on TIGER's Product Data Sheets are subject to change without notification.

This Product Data Sheet supersedes and replaces all previous Product Data Sheet versions and notes to customers published in relation to this product and is only intended to provide a general overview on the product.

Latest versions of Technical Information Sheets and Terms of Delivery and Payment are downloadable from www.tiger-coatings.com and form an integral part of this Product Data Sheet.

Certified according to
ISO 9001 | 14001

TIGER Drylac U.S.A., Inc.
3855 Swenson Avenue
St Charles, IL 60174, USA
T 800 243 8148
F 877 926 8148
E office.us@tiger-coatings.us
W www.tiger-coatings.us