

EXISTING TREE LIST

Tree #	Botanical Name	Common Name	DBH in inches	OAH in feet	Spread in feet	Notes/Condition (All are fair to good unless otherwise noted)
1	<i>Bursera simaruba</i>	Gumbo limbo	9.5	12-14	18-22	To remain
2	<i>Quercus virginiana</i>	Live oak	25	35-40	25-30	To remain
3	<i>Schefflera actinophylla</i>	Umbrella tree	15	25-30	20-25	Invasive species to be removed
4	<i>Quercus virginiana</i>	Live oak	12	30-35	15-20	To remain
5	<i>Quercus virginiana</i>	Live oak	11.5	35-40	20-25	To remain
6	<i>Washingtonia robusta</i>	Washingtonia palm	13	50-60	12-14	Exempt from permit requirements
7	<i>Washingtonia robusta</i>	Washingtonia palm	13	50-60	12-14	Exempt from permit requirements
8	<i>Washingtonia robusta</i>	Washingtonia palm	13	35-40	12-14	Exempt from permit requirements
9	<i>Quercus virginiana</i>	Live oak	14	35-40	30-35	To remain
10	<i>Quercus virginiana</i>	Live oak	16	35-40	30-35	To remain
11	<i>Washingtonia robusta</i>	Washingtonia palm	14	60-65	12-14	Exempt from permit requirements
12	<i>Cocos nucifera</i>	Coconut palm	9	40-45	20-25	To be removed
13	<i>Cocos nucifera</i>	Coconut palm	9	30-35	20-25	To be removed
14	<i>Cocos nucifera</i>	Coconut palm	9	35-40	20-25	To be removed
15	<i>Washingtonia robusta</i>	Washingtonia palm	14	60-65	12-14	Exempt from permit requirements
16	<i>Sabal palmetto</i>	Sabal palm	8	30-35	10-12	To be relocated
17	<i>Sabal palmetto</i>	Sabal palm	8	30-35	10-12	To be relocated
18	<i>Quercus virginiana</i>	Live oak	3	10-11	6-8	To remain
19	<i>Quercus virginiana</i>	Live oak	3	10-11	6-8	To remain
20	<i>Quercus virginiana</i>	Live oak	3	10-11	6-8	To remain
21	<i>Quercus virginiana</i>	Live oak	3	10-11	6-8	To remain
22	<i>Quercus virginiana</i>	Live oak	3	10-11	6-8	To remain
23	<i>Tabebuia heterophylla</i>	Pink trumpet tree	12	35-40	20-25	To be relocated on site
24	<i>Quercus virginiana</i>	Live oak	16	20-25	20-25	To remain
25	<i>Sabal palmetto</i>	Sabal palm	8	30-35	10-12	To be relocated on site
26	<i>Sabal palmetto</i>	Sabal palm	8	30-35	10-12	To be relocated on site
27	<i>Sabal palmetto</i>	Sabal palm	8	30-35	10-12	To be relocated on site
28	<i>Sabal palmetto</i>	Sabal palm	8	30-35	10-12	To be relocated on site
29	<i>Sabal palmetto</i>	Sabal palm	8	30-35	10-12	To be relocated on site
30	<i>Sabal palmetto</i>	Sabal palm	8	30-35	10-12	To be relocated on site
31	<i>Sabal palmetto</i>	Sabal palm	8	20-25	10-12	To be relocated on site
32	<i>Sabal palmetto</i>	Sabal palm	8	25-30	10-12	To be relocated on site
33	<i>Sabal palmetto</i>	Sabal palm	7	30-35	10-12	To be relocated on site
34	<i>Sabal palmetto</i>	Sabal palm	7	25-30	10-12	To be relocated on site
35	<i>Sabal palmetto</i>	Sabal palm	10	30-35	10-12	To be relocated on site
36	<i>Sabal palmetto</i>	Sabal palm	6	30-35	10-12	To be relocated on site
37	<i>Sabal palmetto</i>	Sabal palm	7	30-35	10-12	To be relocated on site
38	<i>Phoenix sylvestris</i>	Date palm	12	25-30	15-20	To be relocated on site
38A	<i>Schefflera actinophylla</i>	Umbrella tree	24	40-45	30-35	Invasive species to be removed
39	<i>Sabal palmetto</i>	Sabal palm	8	20-25	10-12	To be relocated on site
40	<i>Sabal palmetto</i>	Sabal palm	8	30-35	10-12	To be relocated on site
41	<i>Sabal palmetto</i>	Sabal palm	8	30-35	10-12	To be relocated on site
42	<i>Phoenix reclinata</i>	Senegal Date palm	40	25-30	30-35	To be removed. Category 1, no mitigation required
43	<i>Sabal palmetto</i>	Sabal palm	8	30-35	10-12	To be relocated on site
44	<i>Sabal palmetto</i>	Sabal palm	8	30-35	10-12	To be relocated on site
45	<i>Sabal palmetto</i>	Sabal palm	8	40-45	10-12	To be relocated on site
46	<i>Bucida buceras</i>	Black Olive	28	40-45	30-35	To remain. Recommended pruning off roadway
47	<i>Bucida buceras</i>	Black Olive	24	40-45	60-65	To remain
48	<i>Ravenala madagascariensis</i>	Travelers Palm	16	15-20	15-20	To be removed
49	<i>Bursera simaruba</i>	Gumbo limbo	7	12-14	15-20	To remain
50	<i>Washingtonia robusta</i>	Washingtonia palm	13.5	50-60	12-14	Exempt from permit requirements
51	<i>Quercus virginiana</i>	Live oak	21	30-35	45-50	To remain
52	<i>Washingtonia robusta</i>	Washingtonia palm	13	50-60	12-14	Exempt from permit requirements
53	<i>Washingtonia robusta</i>	Washingtonia palm	N/A	8-10	6-7	Exempt from permit requirements
54	<i>Washingtonia robusta</i>	Washingtonia palm	12	40-45	12-14	Exempt from permit requirements
54A	<i>Washingtonia robusta</i>	Washingtonia palm	N/A	6-7	5-6	Exempt from permit requirements
55	<i>Quercus virginiana</i>	Live oak	20	30-35	40-45	To remain
56	<i>Washingtonia robusta</i>	Washingtonia palm	13	40-45	12-14	Exempt from permit requirements
57	<i>Quercus virginiana</i>	Live oak	20	30-35	40-45	To remain
58	<i>Washingtonia robusta</i>	Washingtonia palm	13	40-45	12-14	Exempt from permit requirements
59	<i>Washingtonia robusta</i>	Washingtonia palm	13	40-45	12-14	Exempt from permit requirements
60	<i>Washingtonia robusta</i>	Washingtonia palm	13	20-25	12-14	Exempt from permit requirements
61	<i>Quercus virginiana</i>	Live oak	12.5	20-25	20-25	Poor condition-remove
62	<i>Washingtonia robusta</i>	Washingtonia palm	13	35-40	12-14	Exempt from permit requirements
63	<i>Ptychosperma elegans</i>	Alexander palm	4	30-35	8-10	Poor condition-remove
64	<i>Sabal palmetto</i>	Sabal palm	8	30-35	10-12	Relocate
65	<i>Sabal palmetto</i>	Sabal palm	8	20-25	10-12	Relocate
66	<i>Thrinax sp.</i>	Thatch palm	4	15-20	6-8	Relocate
67	<i>Thrinax sp.</i>	Thatch palm	4	15-20	6-8	Relocate
68	<i>Thrinax sp.</i>	Thatch palm	4	15-20	6-8	Relocate

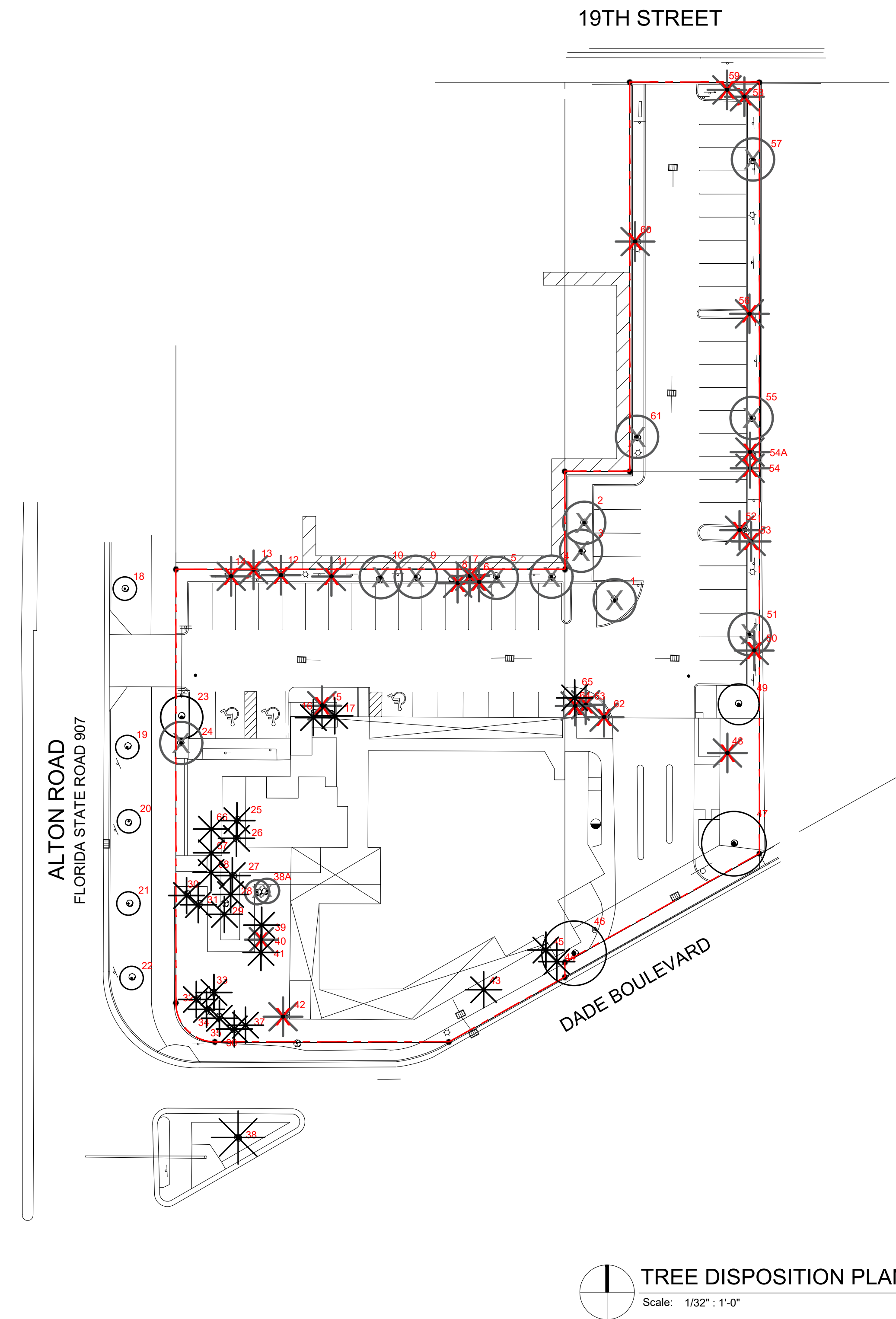
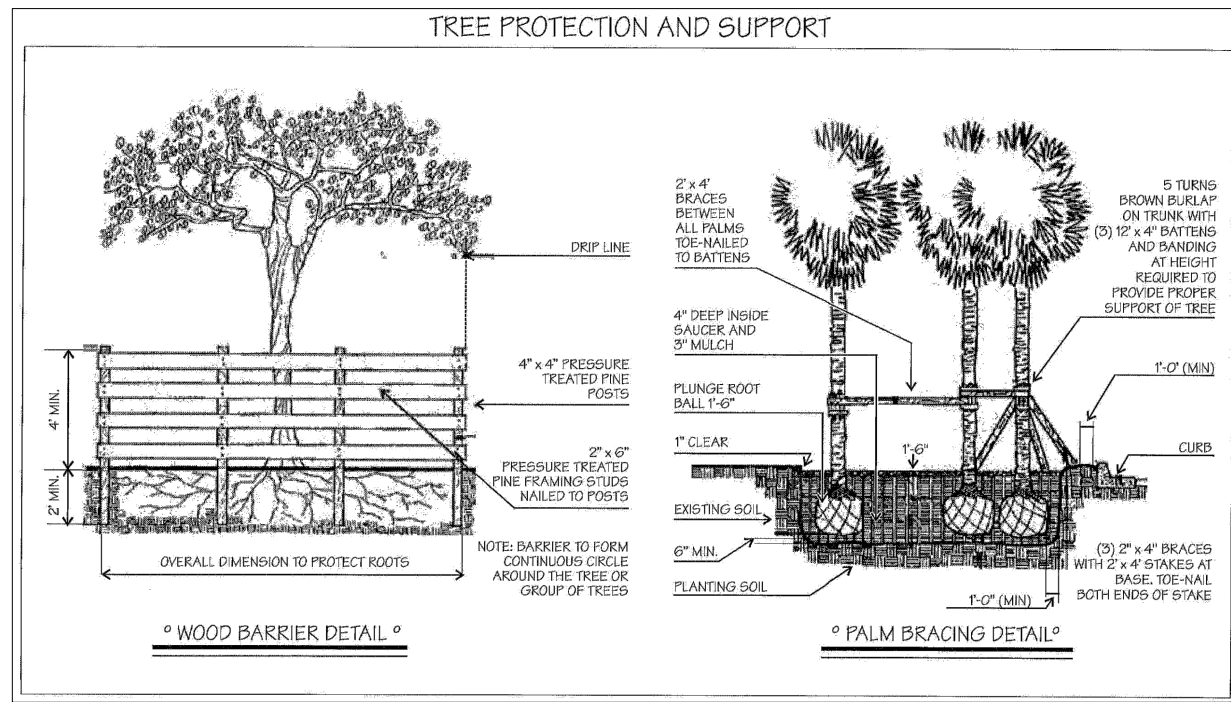
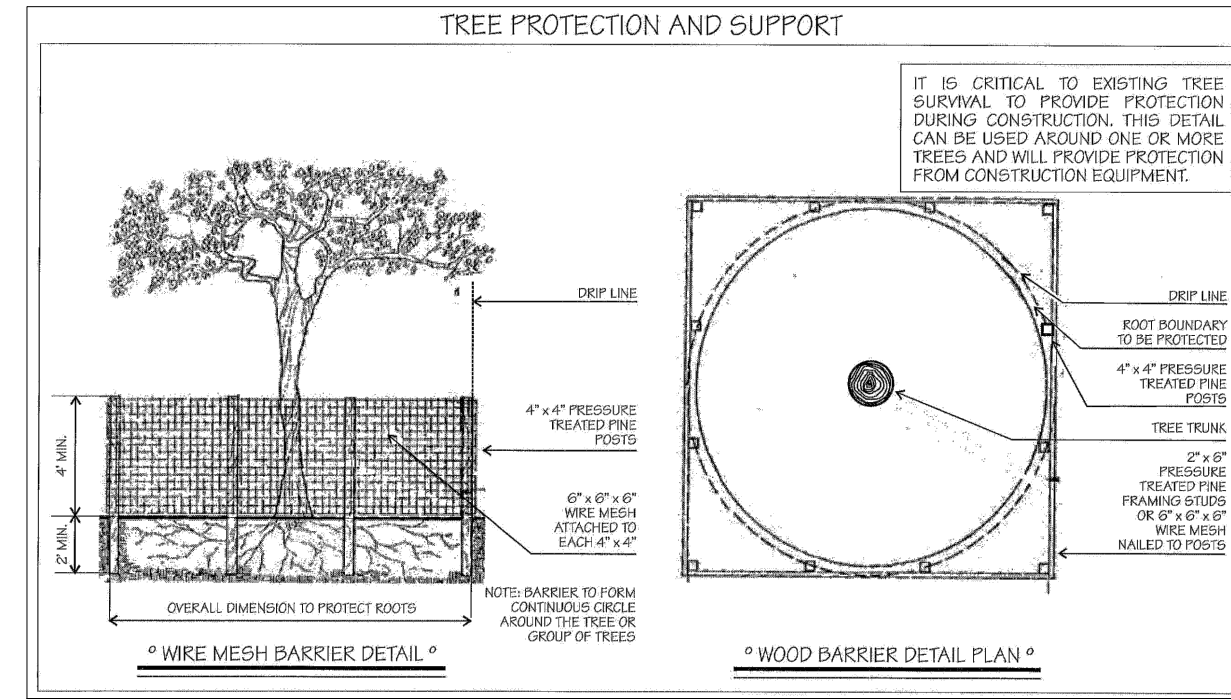

NOTES:

ALL EXISTING TREES TO REMAIN PRESERVE+PROTECT DURING CONSTRUCTION EXCEPT FOR PROHIBITED

EXISTING TREE SYMBOLS ARE GRAPHIC AND LOCATION MAY VARY

EX. TREE SYMBOLS

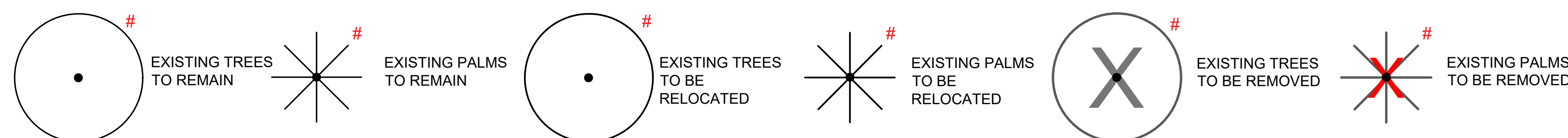

LANDSCAPE ARCHITECT
FL RLA LIC #6667191
9822 NE 2ND AVE SUITE #10
MIAMI SHORES, FL 33138
P. 786.346.8809
www.VincentFiligenzi.com

PROFESSIONAL SEAL:

SEAL:



NOTE:
These architectural drawings and plans are the property of the architect, VFD INC. These drawings and plans shall not be reproduced for use by any individual or entity or any other project without express written permission.

2ND LEVEL COMMERCIAL
TENANT IMPROVEMENT
1801 ALTON ROAD
MIAMI BEACH, FLORIDA 33139

SHEET ISSUE:	REV #	DATE	DESCRIPTION

DRAWN BY: SJ
CHECKED BY: VF
DATE: 03.12.2024

DISCIPLINE / SHEET TITLE:

TREE
DISPOSITION
PLAN

SHEET NUMBER:

LD-1.0

PLANT LIST

PROPOSED PLANT LIST						
SYM	BOTANICAL NAME	COMMON NAME	SPEC	NATIVE	DROUGHT	QTY
TREES + PALMS						
Rre	<i>Roystonea regia</i>	Florida Royal Palm	45' OA 18" GW 20" CAL	*	*	1
Bsi	<i>Bursera simaruba</i>	Gumbo Limbo	20' HT 8"-10" DBH	*	*	2
Tba	<i>Tabebuia bahamensis</i>	Bahama Tabebuia Tree	14'-16' HT OA 4"-6" DBH	*	*	1
Cer1	<i>Conocarpus erectus var. sericeus</i>	Silver Buttonwood Tree	8'-10' OA STD. 2"-3" DBH	*	*	16
Cer2	<i>Conocarpus erectus</i>	Green Buttonwood Tree	18' OA 4"-6" DBH Multi w/ Character	*	*	3
SHRUBS + ACENTS						
PL	<i>Psychotria ligustrifolia</i>	Bahama Coffee	15G		*	21
SR	<i>Serenoa Repens</i>	Silver Saw Palmetto	25G @ 4' HT	*	*	4
TF	<i>Tripsacum floridiana</i>	Gamma Grass	7 GAL	*	*	18
ZP	<i>Zamia pumila</i>	Coontie	3 GAL @ 24" OC	*	*	33
AO	<i>Silver odorata bromeliad</i>	Alcantarea Odorata	30" X 30"		*	9
HP	<i>Hamelia patens</i>	Firebush	15G		*	56
CC	<i>Capparis cynophallophora</i>	Jamaican Caper	25G	*	*	25
CW	<i>Carapa guianensis</i>	Crabwood	25G	*	*	27
CG	<i>Clusia guttifera Hedge</i>	Small Leaf Clusia	25G		*	88
DS	<i>Dioon spinulosum</i>	Giant Dioon	4' HT		*	1
FK	<i>Pennisetum fakahatchee</i>	Fakahatchee Grass	7G	*	*	2
ZF	<i>Zamia Floridaana</i>	Coontie Palm	15G	*	*	4
GROUNDCOVERS						
EL	<i>Emodea littoralis</i>	Golden Creeper	1 GAL @ 18" OC	*	*	35
TF	<i>Tripsacum floridiana</i>	Gamma Grass	3 GAL @ 36" OC	*	*	452
AG	<i>Perennial Peanut</i>	Wild Peanut	1 GAL @ 18" OC	*	*	1430
CM	<i>Carissa</i>	Emerald Blanket	3 GAL @ 24" OC	*	*	165
BM	<i>Philodendron</i>	Burle Marx	3 GAL @ 24" OC		*	116
SOD	<i>Empire Zoysia</i>		2,161 SF			

LANDSCAPE LEGEND

Transect Zone CD-1 Lot Area: 46,845.00 Acres: 1.080 **REQUIRED/ ALLOWED** **PROVIDED**

TREES
A. Number of trees required per net lot acre, less existing number of trees
 meeting minimum requirements =
 22 trees x 1.080 net lot acres - number of existing trees (6) = **18** **22**

B. % Natives required: Number of trees provided x 30% =
 22 x .30 = 7 Native Trees required **7** **21**

C. % Drought tolerant and low maintenance:
 Number of trees provided x 50% =
 22 x .5 = 11 Drought & Low Maintenance Trees required **11** **22**

D. Street Trees (maximum average spacing of 20' o.c.):
 237 linear feet along street / 20 =
 237 / 20 = 12 Street Trees required. **12** **12**

E. Street trees located directly beneath power lines: (maximum average spacing of 20' o.c.): linear feet along street / 20 = **N/A** **N/A**

SHRUBS
A. Number of shrubs required: Number of trees required x 12 =
 18 x 12 = 216 Shrubs required **216** **303**

B. % Native shrubs required: Number of shrubs provided x 30% =
 288 x .30 = Native shrubs required **87** **113**

GENERAL PLANTING NOTES

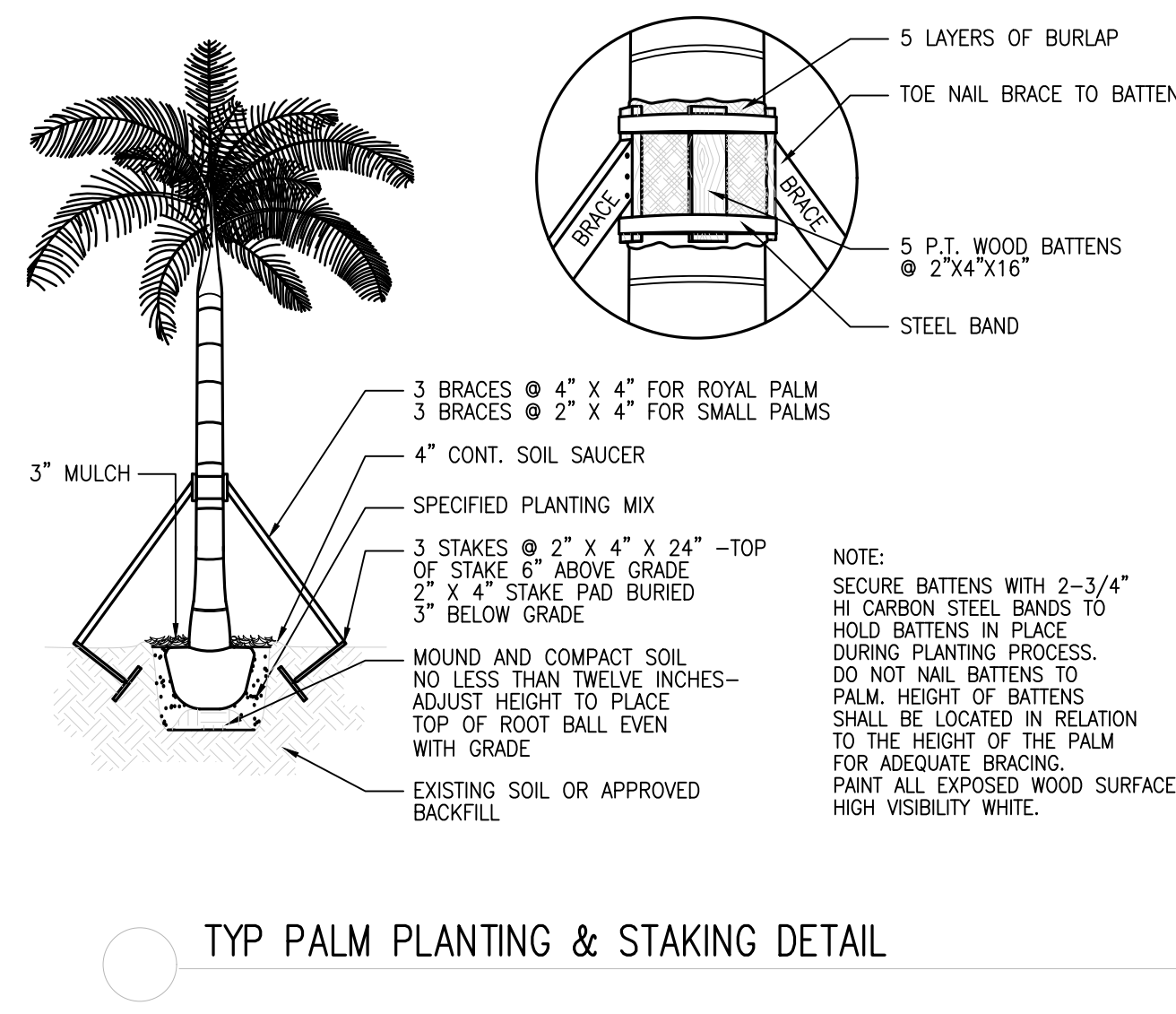
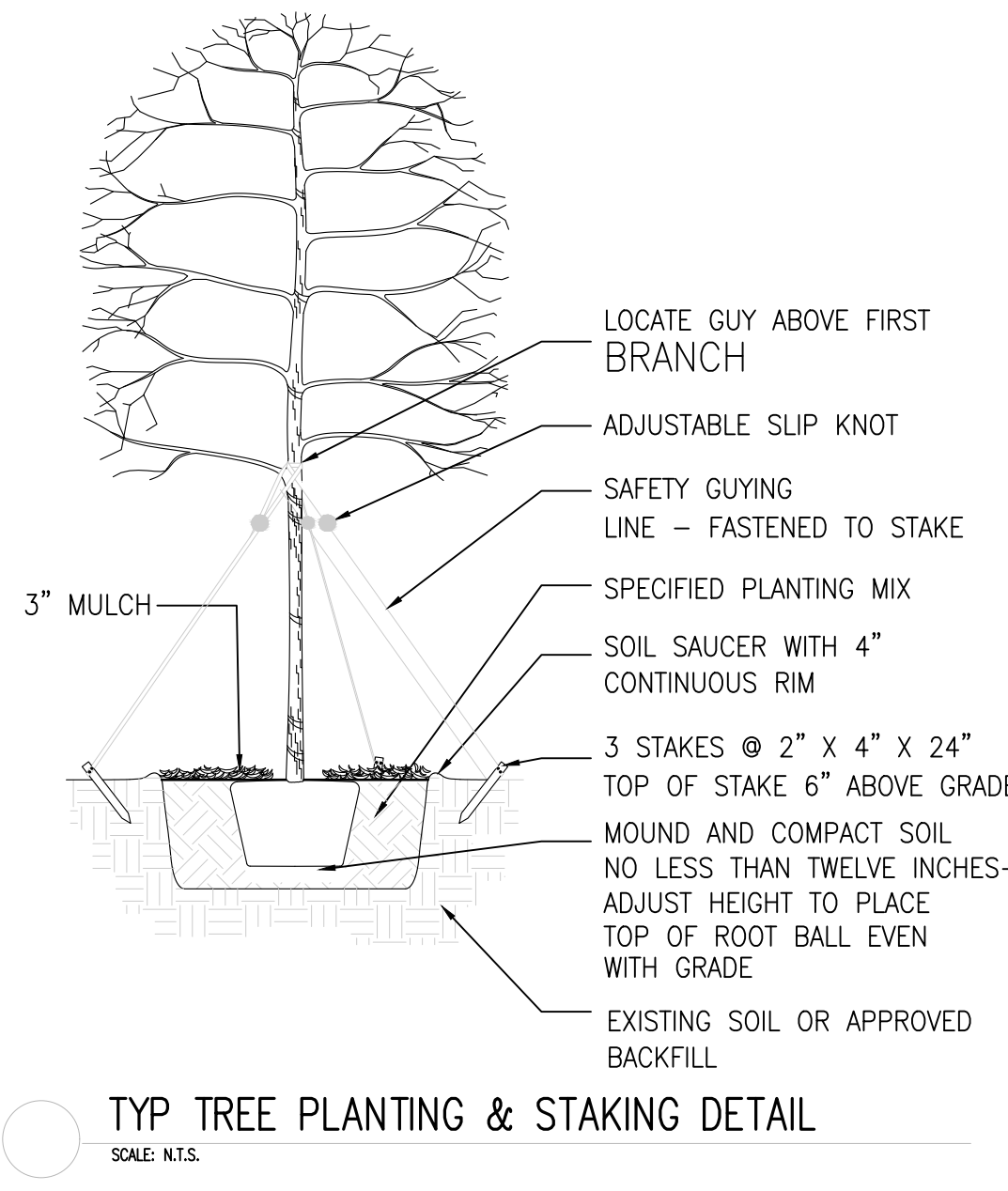
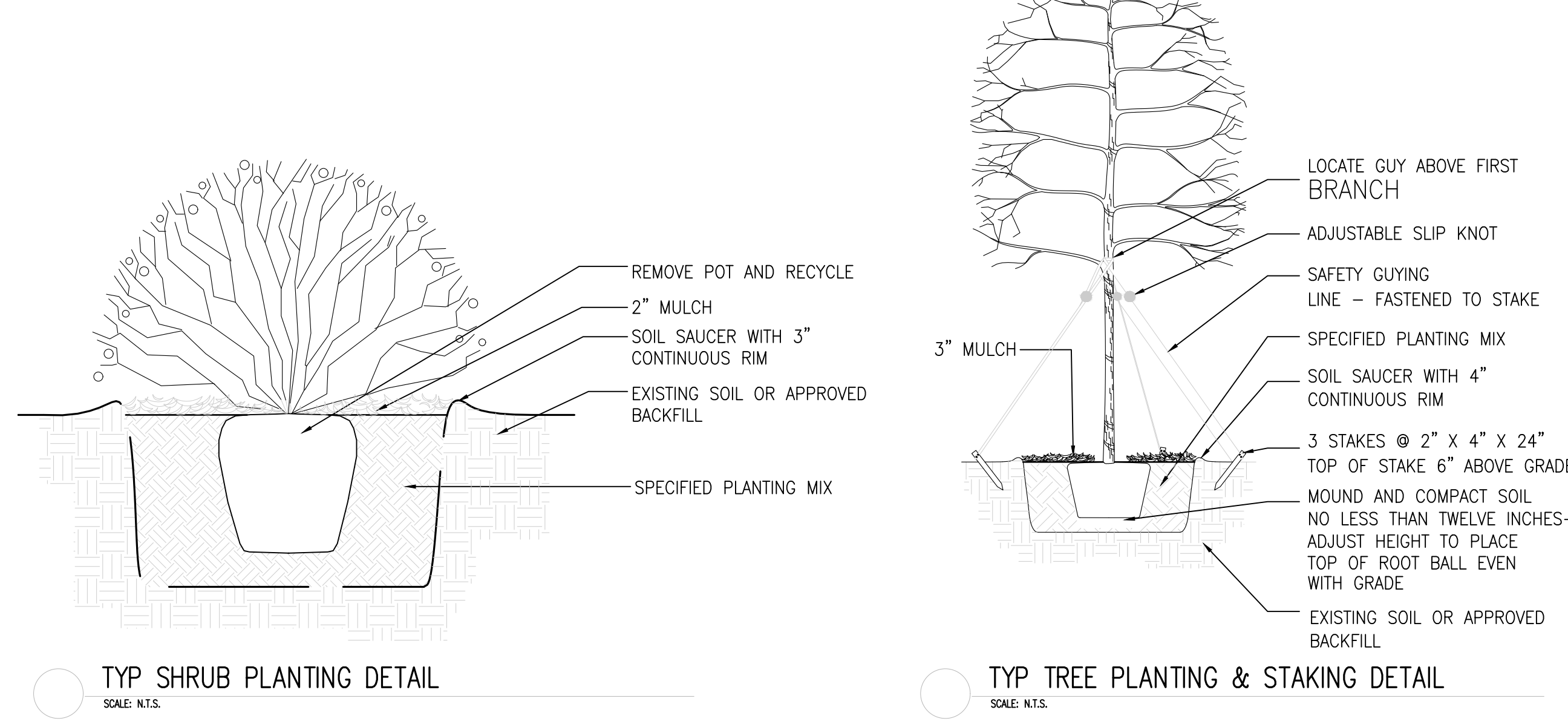

PROPOSED F.A.R. CALCULATIONS

LOCATION	USE	AREA
LEVEL 1:	OFFICE/RETAIL	4,938.69 SF
4,938.69 SF / 300 SF / SPACE=		16.46 SP
TOTAL PARKING REQ'D:		16.46 SP
LEVEL 1 PARKING PROV'D		67 SP
TOTAL PARKING PROV'D:		67 SP

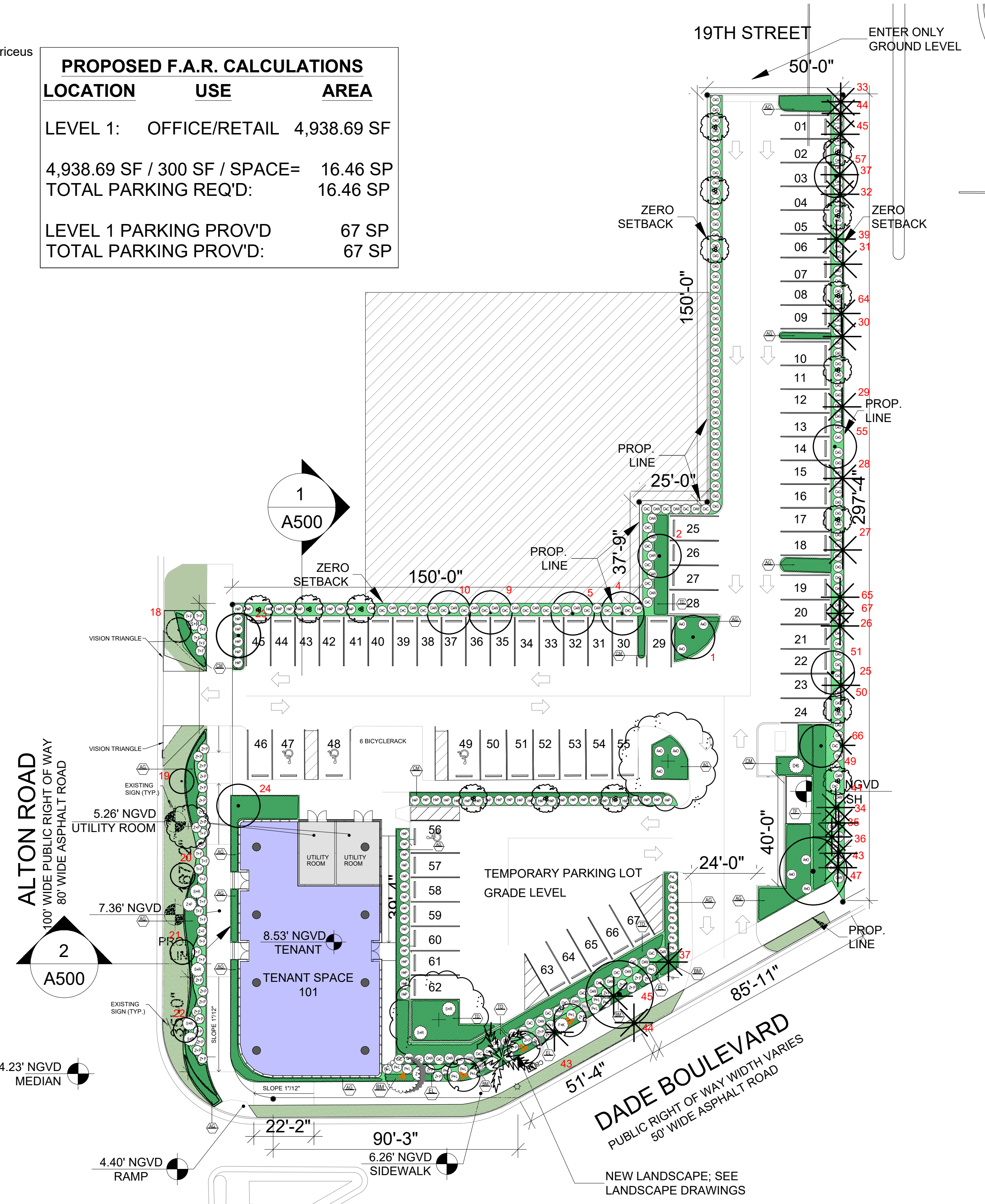

- 8 Conocarpus erectus var. sericeus
- Bursera simaruba
- Roystonea regia
- Tabebuia bahamensis
- Conocarpus erectus
- FAKAHATCHEE
- DIOON
- SILVER SAW PALMETTO
- JAMAICAN CAPER
- GAMMA GRASS
- ZAMIA FLORIDIANA
- ZAMIA PUMILA
- CRABWOOD
- CLUSIA GUTTIFERA
- FIREBUSH
- SILVER BROMELIAD
- BAHAMA COFFEE
- GOLDEN CREEPER
- CORAL CREEPER
- PERENNIAL PEANUT
- GENERAL PLANTING AREA
- PLANTING BED
- LAWN

VFD
 VINCENT FILIGENZI DESIGN
 LANDSCAPE ARCHITECTURE (PLANNING) INCORPORATED
 LANDSCAPE ARCHITECT
 FL. LA. LIC. #6667191
 9822 NE 2ND AVE SUITE #10
 MIAMI SHORES, FL 33138
 P. 786.346.8909
 www.VincentFiligenzi.com

PROFESSIONAL SEAL:
 SEAL:
VINCENT A. FILIGENZI
 LA #6667191

NOTE:
 These architectural drawings and plans are the property of Vincent Filigenzi Design, Inc. These drawings and plans shall not be reproduced for use by any individual or entity or any other project without the express written permission.

2ND LEVEL COMMERCIAL TENANT IMPROVEMENT
 1801 ALTON ROAD
 MIAMI BEACH, FLORIDA 33139

SHEET ISSUE:

REV #	DATE	DESCRIPTION

DRAWN BY:
 CHECKED BY: VF
 DATE: 03.05.2024

DISCIPLINE / SHEET TITLE:
LANDSCAPE PLAN

SHEET NUMBER:
LP-1.0

PLANT LIST

PROPOSED PLANT LIST						
SYM	BOTANICAL NAME	COMMON NAME	SPEC	NATIVE	DROUGHT	QTY
GROUNDCOVERS						
EL	<i>Erodia littoralis</i>	Golden Creeper	1 GAL @ 18" OC	*	*	1310
MULCH						
	Mulch	Pine Straw	2095 SQ FEET			

PLANT SYMBOL

 GOLDEN CREEPER

 GENERAL PLANTING AREA

 PLANTING BED

GREEN ROOF COVERAGE

ROOF AREA	SQ. FEET
GREEN AREA	2339.5
ROOF	2339.5
TOTAL ROOF AREA	4679.46

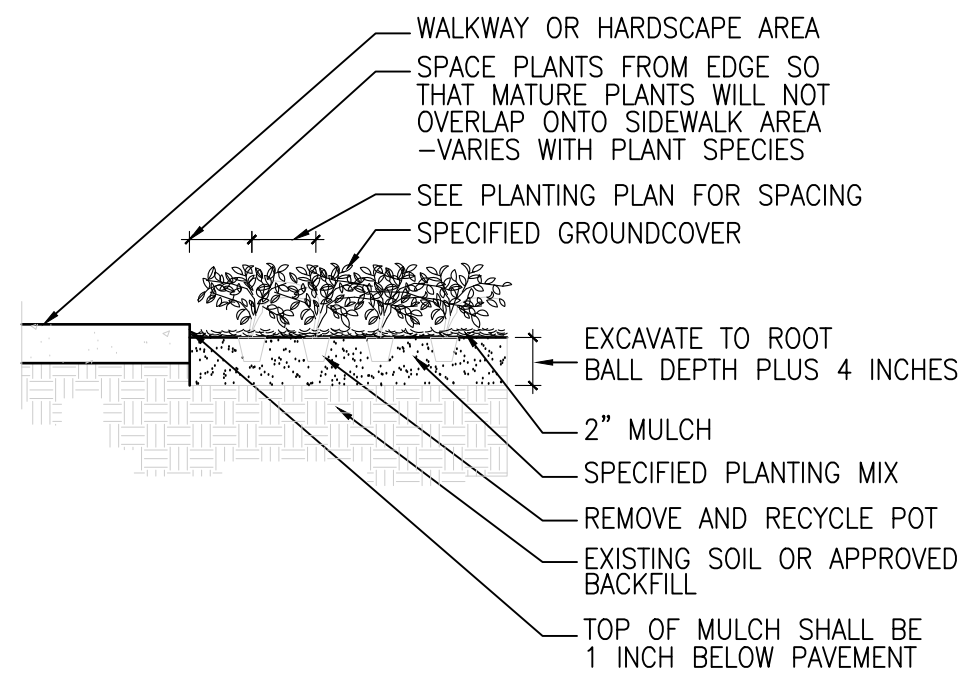

GROUNDCOVER EDGE PLANTING CONDITION
SCALE: N.T.S.

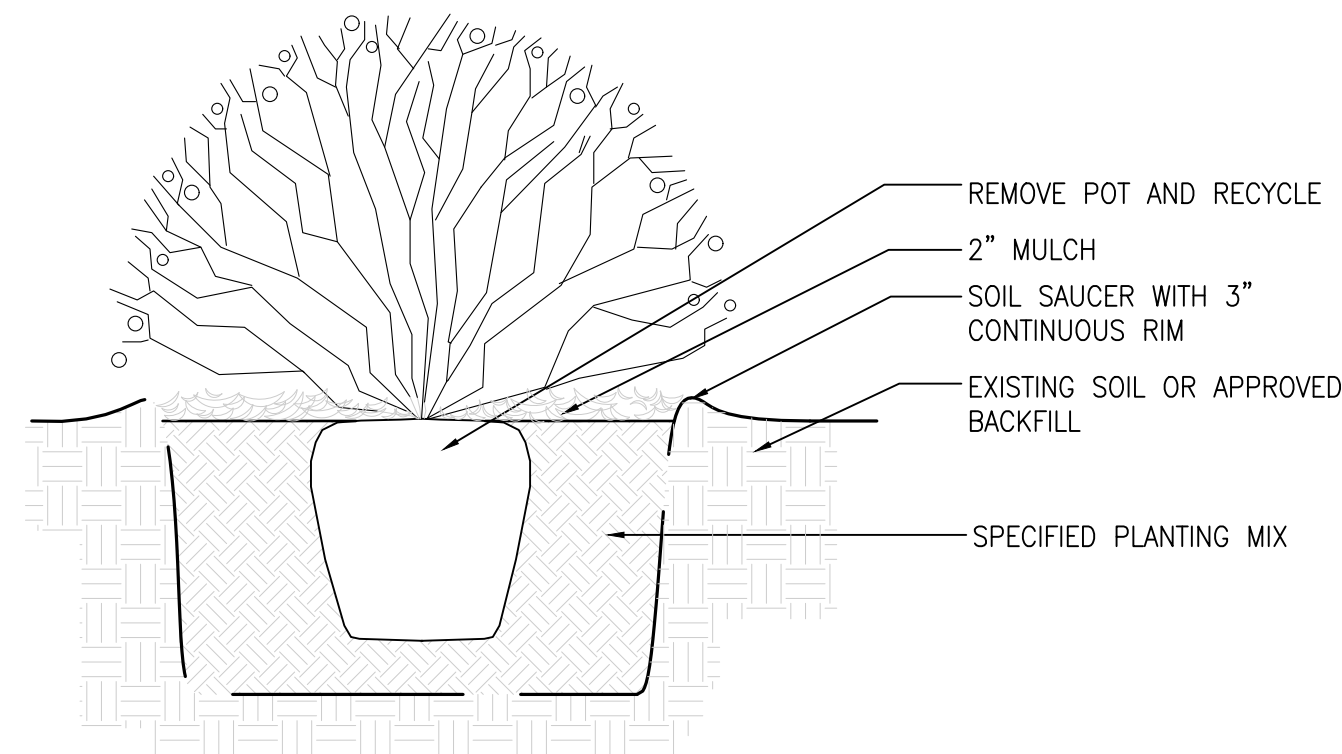

TYP SHRUB PLANTING DETAIL
SCALE: N.T.S.

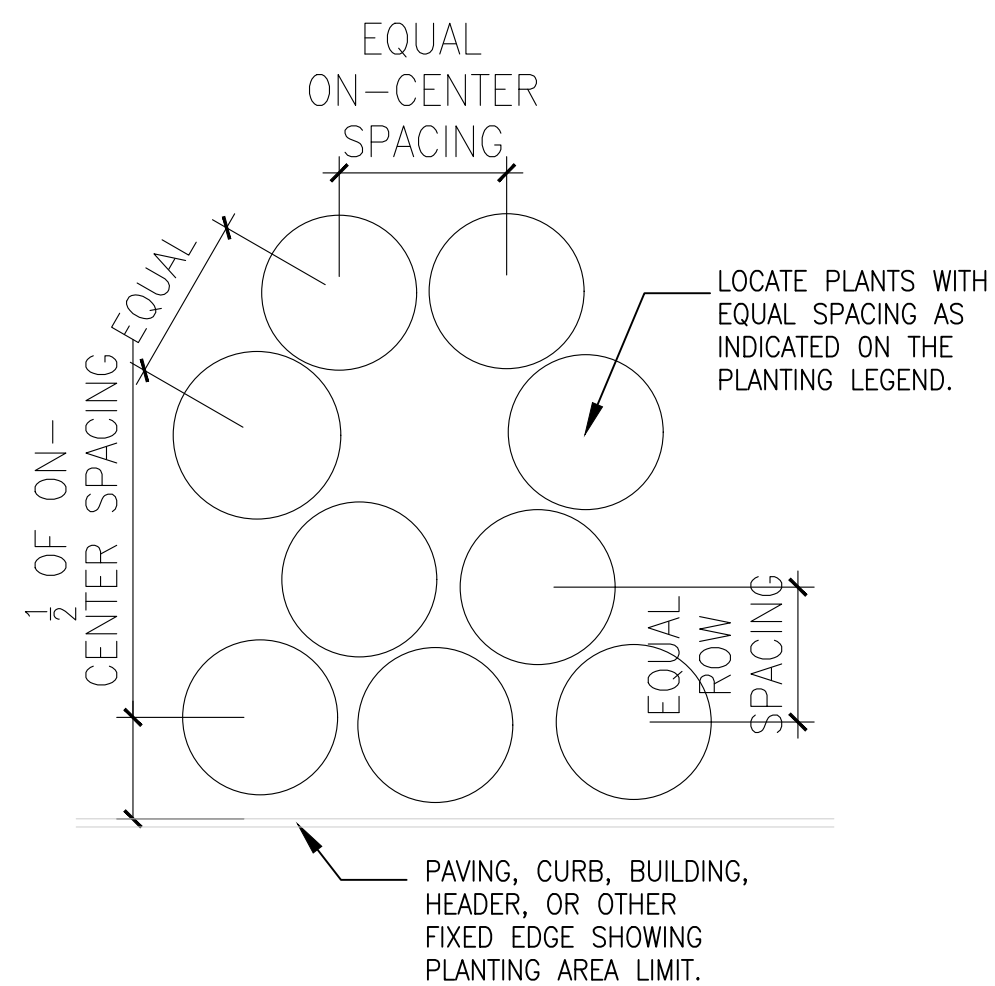

TYP SHRUB SPACING DETAIL

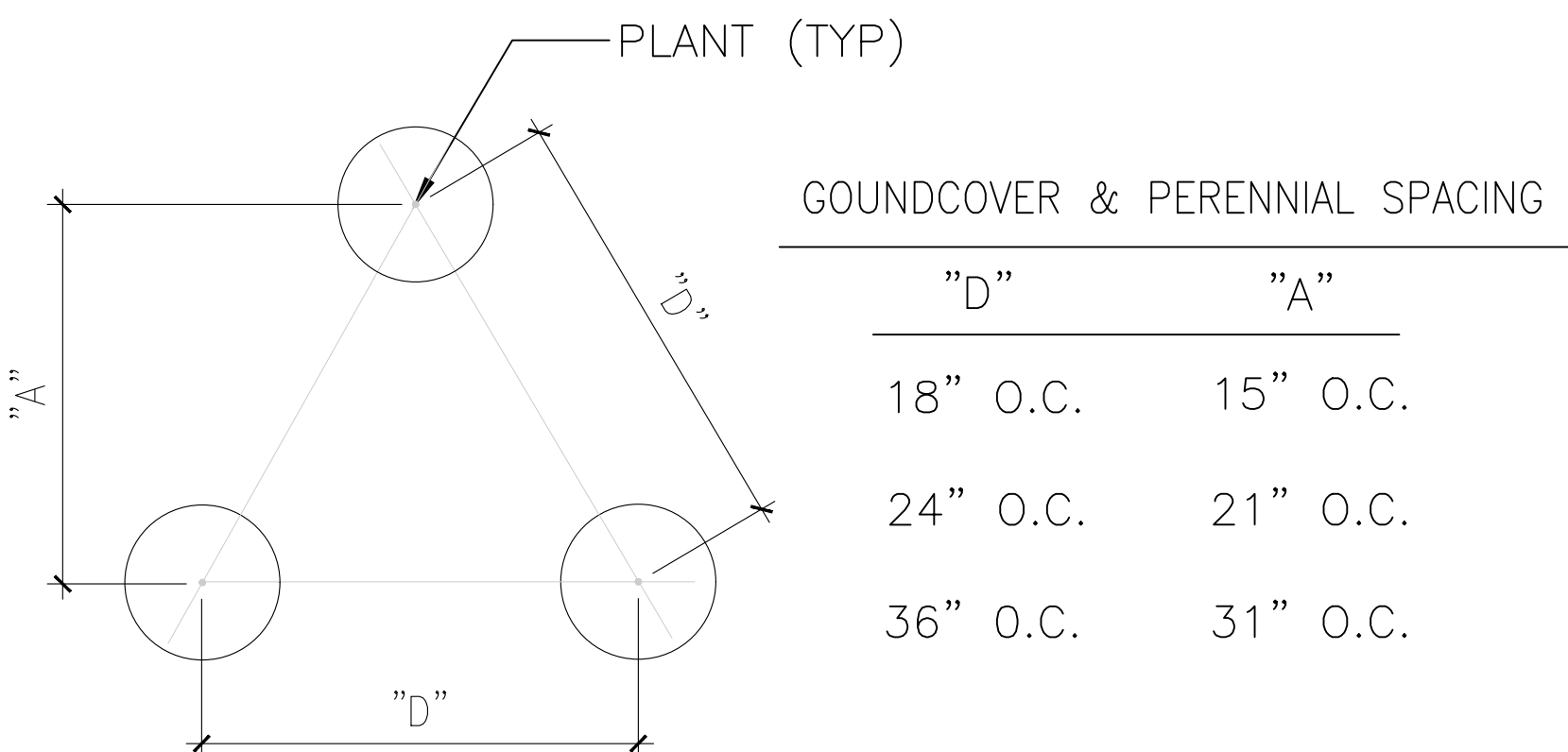

TYP TRIANGULAR PLANT SPACING CHART FOR GROUNDCOVERS
SCALE: N.T.S.

ALTON ROAD
FLORIDA STATE ROAD 907

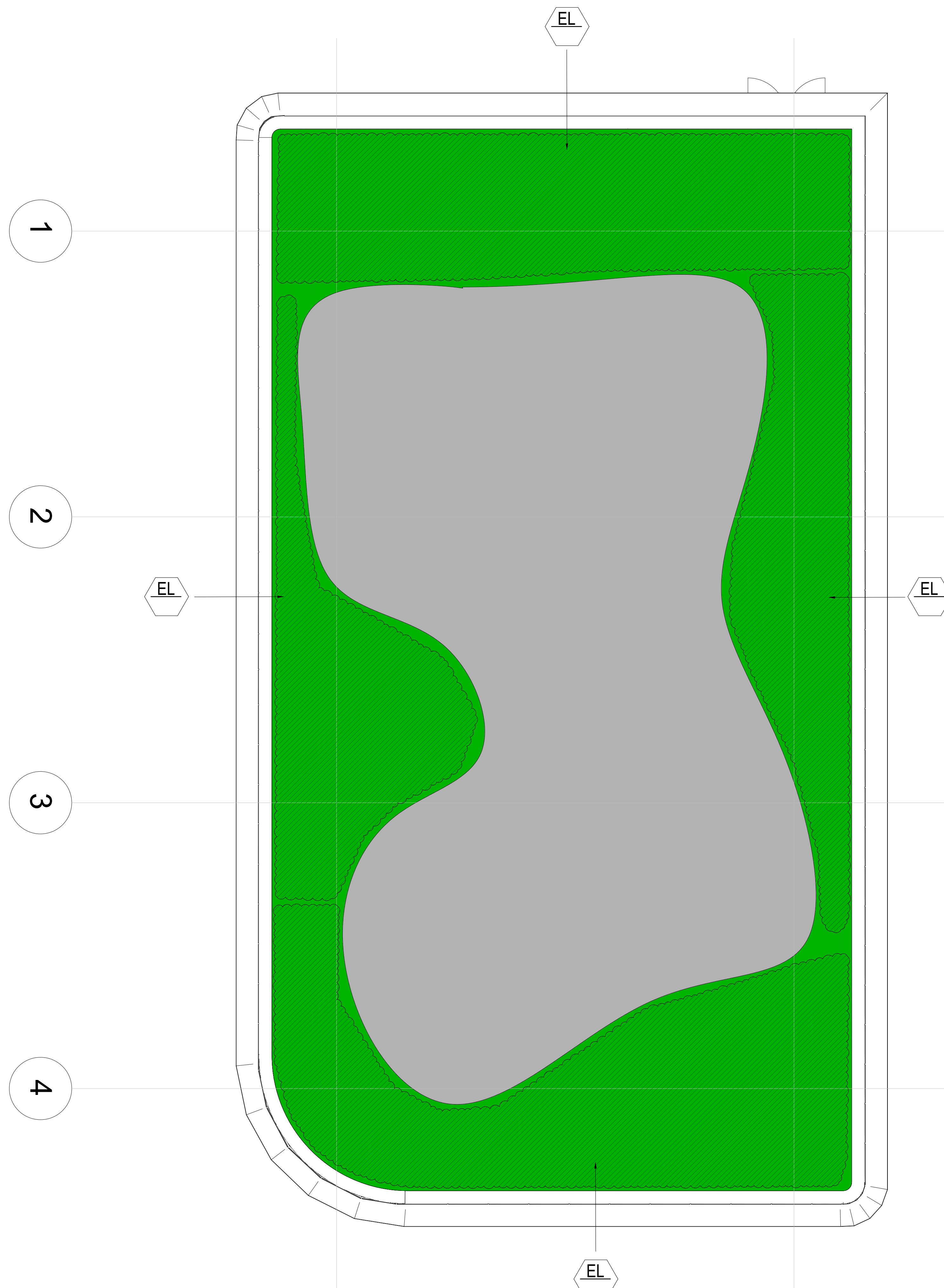

OVERALL ROOFTOP PLAN
Scale: 3/32" = 1'-0"



LANDSCAPE ARCHITECT
FL RLA LIC #6667191
9822 NE 2ND AVE SUITE #10
MIAMI SHORES, FL 33138
P. 786.346.8909
www.VincentFiligenzi.com

PROFESSIONAL SEAL:

SEAL:

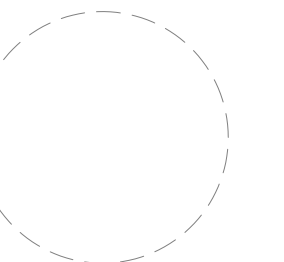

VINCENT A. FILIGENZI
LA #6667191

NOTE:
These architectural drawings and plans are the property of Vincent Filigenzi Design, VFD INC. These drawings and plans shall not be reproduced for use by any individual or entity or any other project without the express written permission.

2ND LEVEL COMMERCIAL
TENANT IMPROVEMENT
1801 ALTON ROAD
MIAMI BEACH, FLORIDA 33139

SHEET ISSUE:	REV #	DATE	DESCRIPTION

DRAWN BY:
CHECKED BY: VF
DATE: 03.05.2024

DISCIPLINE / SHEET TITLE:

ROOFTOP
PLAN

SHEET NUMBER:

LP-1.2