

EXISTING TREE DISPOSITION LIST									
KEY	BOTANICAL NAME	COMMON NAME	SIZE			DISPOSITION	NOTES	MITIGATION	
			HT.(ft.)	SPD.(ft.)	DBH.(in.)			DBH.(in.)	
1	Adonidia merillii	Christmas Palm	14	8	5	remove	dead	not a tree	
2	Adonidia merillii	Christmas Palm	14	8	5	remove	good	not a tree	
3	Adonidia merillii	Christmas Palm	14	8	5	remove	good	not a tree	
4	Adonidia merillii	Christmas Palm	14	8	5	remove	good	not a tree	
5	Adonidia merillii	Christmas Palm	14	8	5	remove	good	not a tree	
6	Persea Americana	Avocado tree	18	12	6	remove		6	
7	Veitchia montgomeryana	Montgomery Palm	16	12	6	remove		1 palm	
TOTAL DBH INCHES TO BE REMOVED								6	
TOTAL PALMS TO BE REMOVED								1	
TOTAL DBH INCHES MITIGATION REQUIRED								(2) - 2" dbh trees to replace the avocado + (1) - 2" dbh trees to replace the palm = (3) - 2" dbh trees	
TOTAL DBH INCHES MITIGATION PROVIDED								(6) - 2" dbh trees	

TREE / PALM PROTECTION FENCES SHALL BE CONSTRUCTED PRIOR TO ANY CONSTRUCTION ACTIVITY INCLUDING GRUBBING FOR ALL TREES / PALMS THAT ARE TO REMAIN, BE PROTECTED, or BE RELOCATED'

NO ACTIVITY OR DISTURBANCE SHOULD OCCUR WITHIN THE FENCED AREAS, INCLUDING VEHICLE USE, STORAGE OF MATERIALS, DUMPING OF LIQUIDS OR MATERIALS, GRADE CHANGES, GRUBBING, AND MECHANICAL TRENCHING FOR IRRIGATION, ELECTRICAL, LIGHTING, ETC.

In no case shall the fence be installed less than ten feet from the trunk

Tree + Palm protection barriers to extend beyond the 'dripline' or to the 'critical root zone area' of all trees/palms to be protected. Extend where necessary to protect tree canopy roots

Barriers shall be a minimum of four feet high, and shall be constructed of continuous chain link fence with metal posts at eight-foot spacing, or of two-by-four-inch posts with three equally spaced two-by-four-inch rails. Posts may be shifted to avoid roots.

PROTECTION DETAIL NOTE
 CONTRACTOR TO INSTALL 'TREE / PALM PROTECTION FENCE BARRIERS' AROUND ALL EXISTING TREES OR PALMS AT THE START OF THE PROJECT. BARRIERS TO REMAIN IN PLACE THROUGHOUT THE DURATION OF THE PROJECT AND SHOULD NOT BE REMOVED OR DROPPED FOR ANY REASON WITHOUT AUTHORIZATION FROM THE CITY OF MIAMI BEACH URBAN FORESTER + PLANNING + ZONING DEPARTMENT

C.M.B. TREE / PALM PROTEC. DETAIL

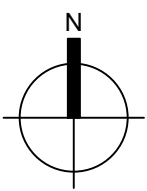

Existing Tree Disposition Plan

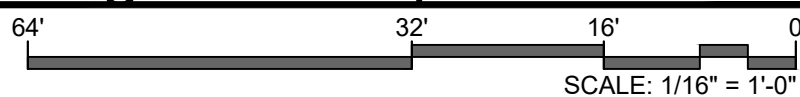

CASA LEROY
 1339 14TH TERRACE MIAMI BEACH, FLORIDA 33139
MATEU ARCHITECTURE, INC.
 8887 SW 131 STREET MIAMI, FLORIDA 33176
 TEL: 305.233.3304 FAX: 305.233.3306
 17470 NW 78th AVE., SUITE 214 WIAH, FL 33091-1520 P 305.392.1010 F 305.392.1019 CORP. ID # 0000266
 FIRST SUBMITTAL 04.29.2024

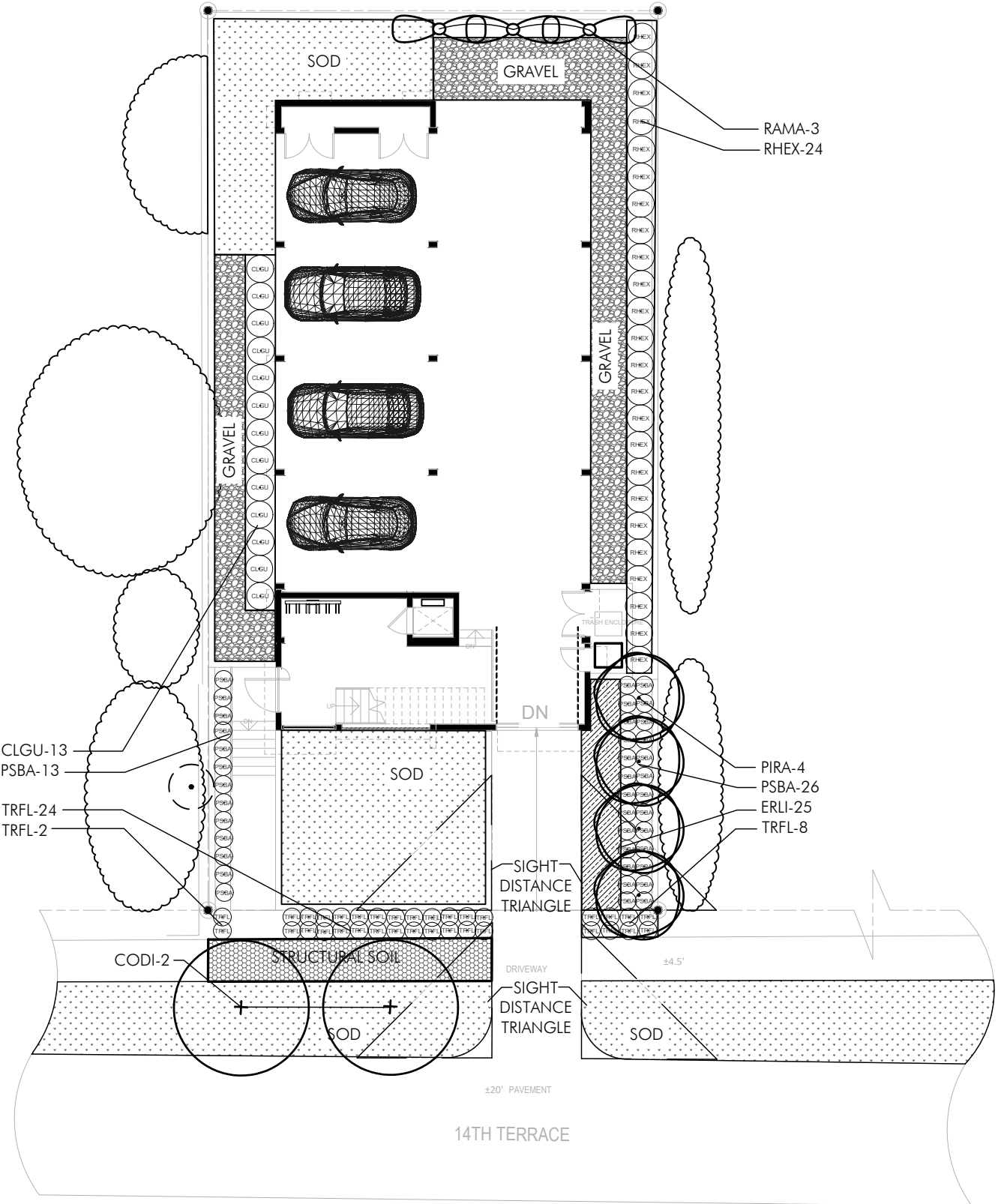

PLANT LIST - GROUND FLOOR				
TREES				
KEY	PLANT NAME	QTY.	UT.	SIZE
CODI	Coccoloba diversifolia ...Pigeon Plum	2	ea.	12' tall x 5' spread, 2" DBH
PIRA	Pimenta racemosa 'lemon' ..Bay Rum Tree	4	ea.	12' tall x 5' spread, 2" DBH
OTHER				
KEY	PLANT NAME	QTY.	UT.	SIZE
RAMA	Ravanelo madagascariensis Traveler's Palm	3	ea.	8' tall overall
SHRUBS				
KEY	PLANT NAME	QTY.	UT.	SIZE
PSBA	Psychotria bahamensis ...Bahamas Wild Coffee	39	ea.	24" x 24"
TRFL	Tripsacum floridanum ...Florida Gamagrass	34	ea.	18" x 18", install 24" o.c.
RHEX	Rhapis excelsa ...Lady Palm	24	ea.	4' tall x 30" spread, multi
LARGE SHRUBS				
KEY	PLANT NAME	QTY.	UT.	SIZE
CLGU	Clusia guttifera ...Clusia	13	ea.	6' tall x 3' spread, full to ground
GROUNDCOVERS				
KEY	PLANT NAME	QTY.	UT.	SIZE
ERLI	Emodea littoralis ...Golden Creeper	25	ea.	3 gal cans, full, install 18" o.c.
MISCELLANEOUS				
gravel	Decorative gravel to be selected	as req.	c.y.	as required
sod	"Empire" Zoysia Sod	as req.	s.f.	as required
	Planting Soil 70% Silica Sand 20% Everglades Muck 10% Shredded Pinebark	as req.	c.y.	excavate and backfill 18" depth in all planting areas.
	Roof Planter Soil Mix 25% Coarse Sand 25% Medium Sand 20% Pine Bark 20% Florida Peat 8% Rice Rock 2% Marl	as req.	c.y.	
	Shredded Melaleuca Mulch	as req.	c.y.	3" layer in all shrub beds
	CU Structural Soil	as req.	c.y.	30" deep under sidewalk

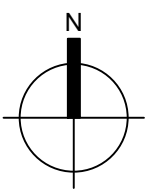

Ground Floor Planting Plan

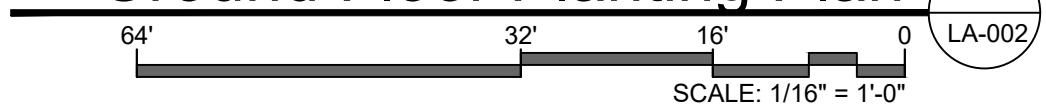

CASA LEROY
1339 14TH TERRACE MIAMI BEACH, FLORIDA 33139
MATEU ARCHITECTURE, INC.
8887 SW 131 STREET MIAMI, FLORIDA 33176
TEL: 305.233.3304
FAX: 305.233.3308
FIRST SUBMITTAL 04.29.2024

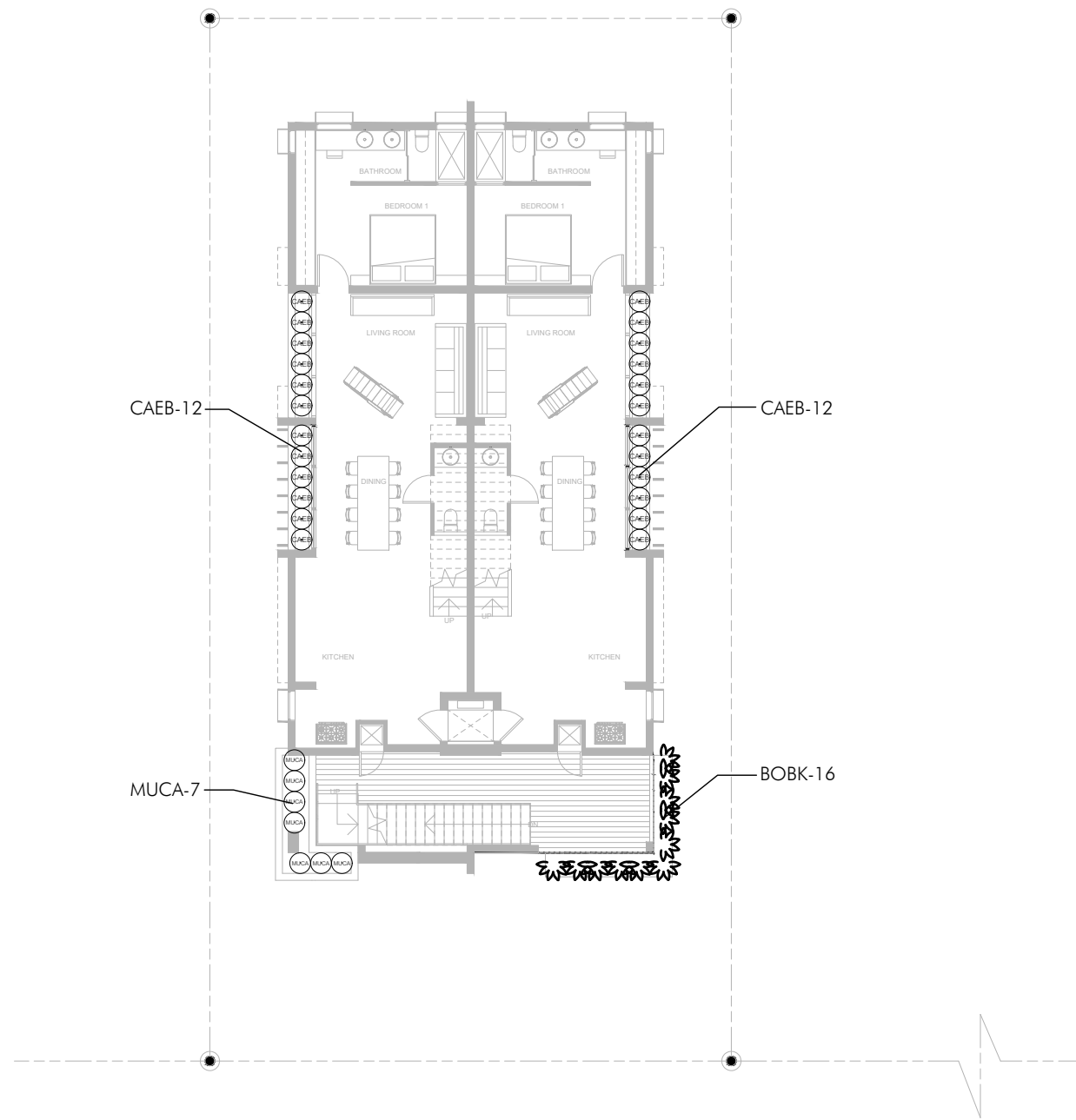

PLANT LIST - SECOND FLOOR

SHRUBS				
KEY	PLANT NAME	QTY.	UT.	SIZE
BOBK	Bougainvillea spectabilis "Barbara Karst" ...Bougainvillea Barbara Karst	16	ea.	3 gallon cans, trellised
CAEB	Carissa macrocarpa "Emerald Blanket" ...Natal Plum	24	ea.	3 gallon cans, 18" spread
MUCA	Muhlenberghia cappillaris ...Muhly Grass	7	ea.	3 gallon cans, full

MISCELLANEOUS

Green Roof Soil Mixes From Atlas Soil				
	Roof Planter Soil Mix	as req.	c.y.	
	25% Coarse Sand			
	25% Medium Sand			
	20% Pine Bark			
	20% Florida Peat			
	8% Rice Rock			
	2% Marl			
	Shredded Melaleuca Mulch	as req.	c.y.	3" layer in all shrub beds

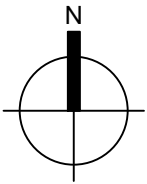

Second Floor Planting Plan

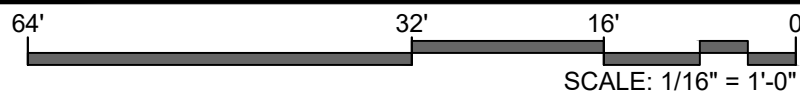

LA-003



CASA LEROY
 1339 14TH TERRACE MIAMI BEACH, FLORIDA 33139
MATEU ARCHITECTURE, INC.
 8887 SW 131 STREET MIAMI, FLORIDA 33176
 TEL: 305.233.3304 FAX: 305.233.3308
 17470 NW 78th AVE., SUITE 214 MIAMI, FL 33157
 P 305.392.1016 F 305.392.1019
 CORP. ID # 0000266

FIRST SUBMITTAL 04.29.2024

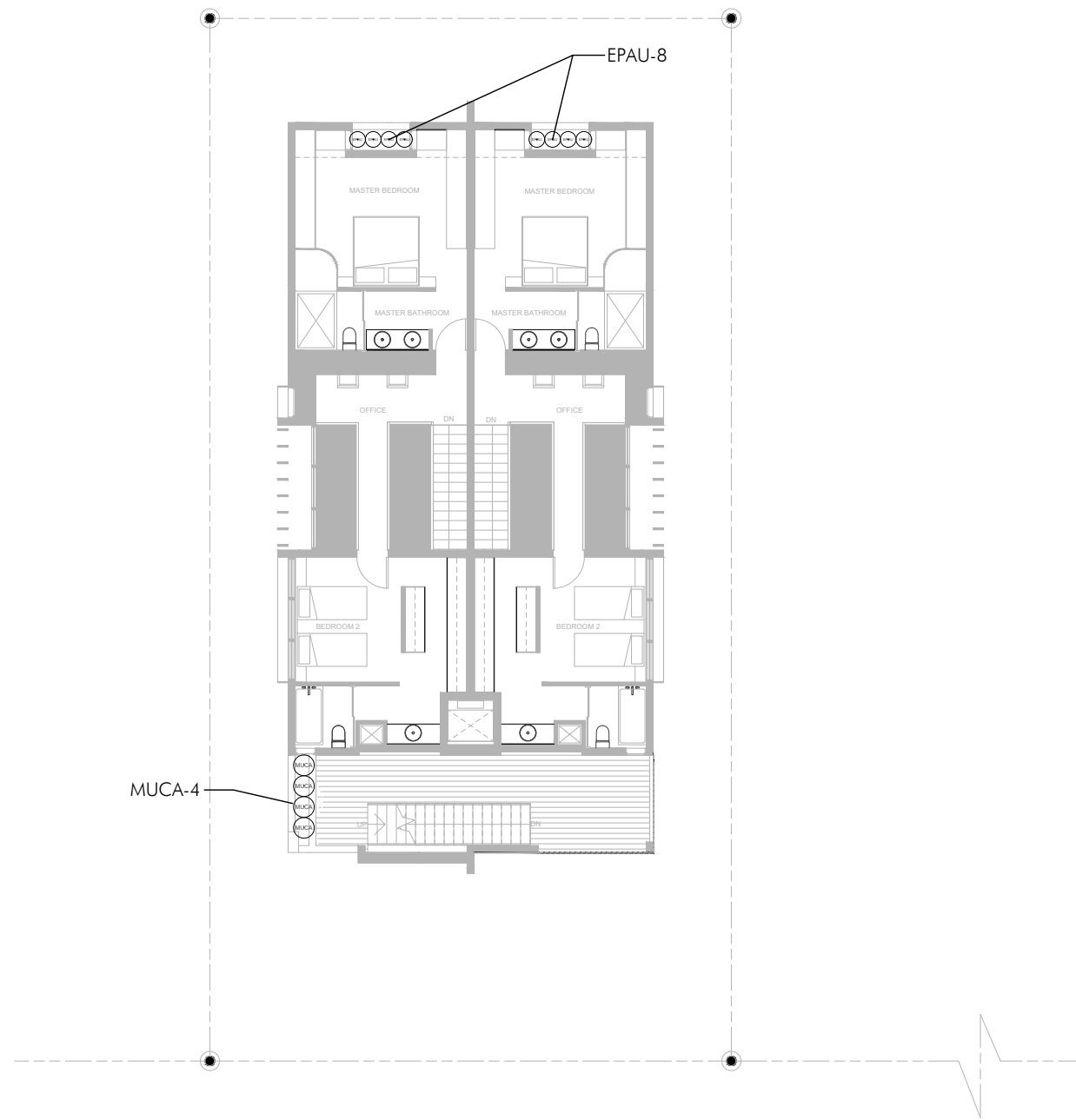

PLANT LIST - THIRD FLOOR				
SHRUBS				
KEY	PLANT NAME	QTY.	UT.	SIZE
EPAU	Epipremnum aureum ...Golden Pothos	8	ea.	1 gallon cans, 12" spread
MUCA	Muhlenberghia cappillaris ...Muhly Grass	4	ea.	3 gallon cans, full
MISCELLANEOUS				
Green Roof Soil Mixes From Atlas Soil				
	Roof Planter Soil Mix	as req.	c.y.	
	25% Coarse Sand			
	25% Medium Sand			
	20% Pine Bark			
	20% Florida Peat			
	8% Rice Rock			
	2% Marl			
	Shredded Melaleuca Mulch	as req.	c.y.	3" layer in all shrub beds

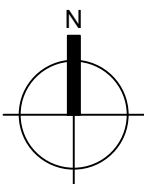

Third Floor Planting Plan

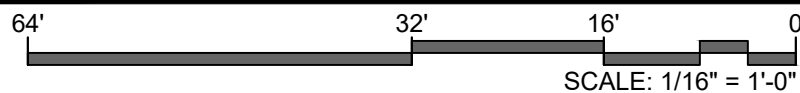

CASA LEROY
 1339 14TH TERRACE MIAMI BEACH, FLORIDA 33139
MATEU ARCHITECTURE, INC.
 8887 SW 131 STREET MIAMI, FLORIDA 33176
 TEL: 305.233.3304 FAX: 305.233.3308
 17470 NW 78th AVE., SUITE 214
 M.I.A.M.I., FL. 33015
 P. 305.392.1016 F. 305.392.1019
 C.O.R.P. 1 D # 0000266

FIRST SUBMITTAL 04.29.2024

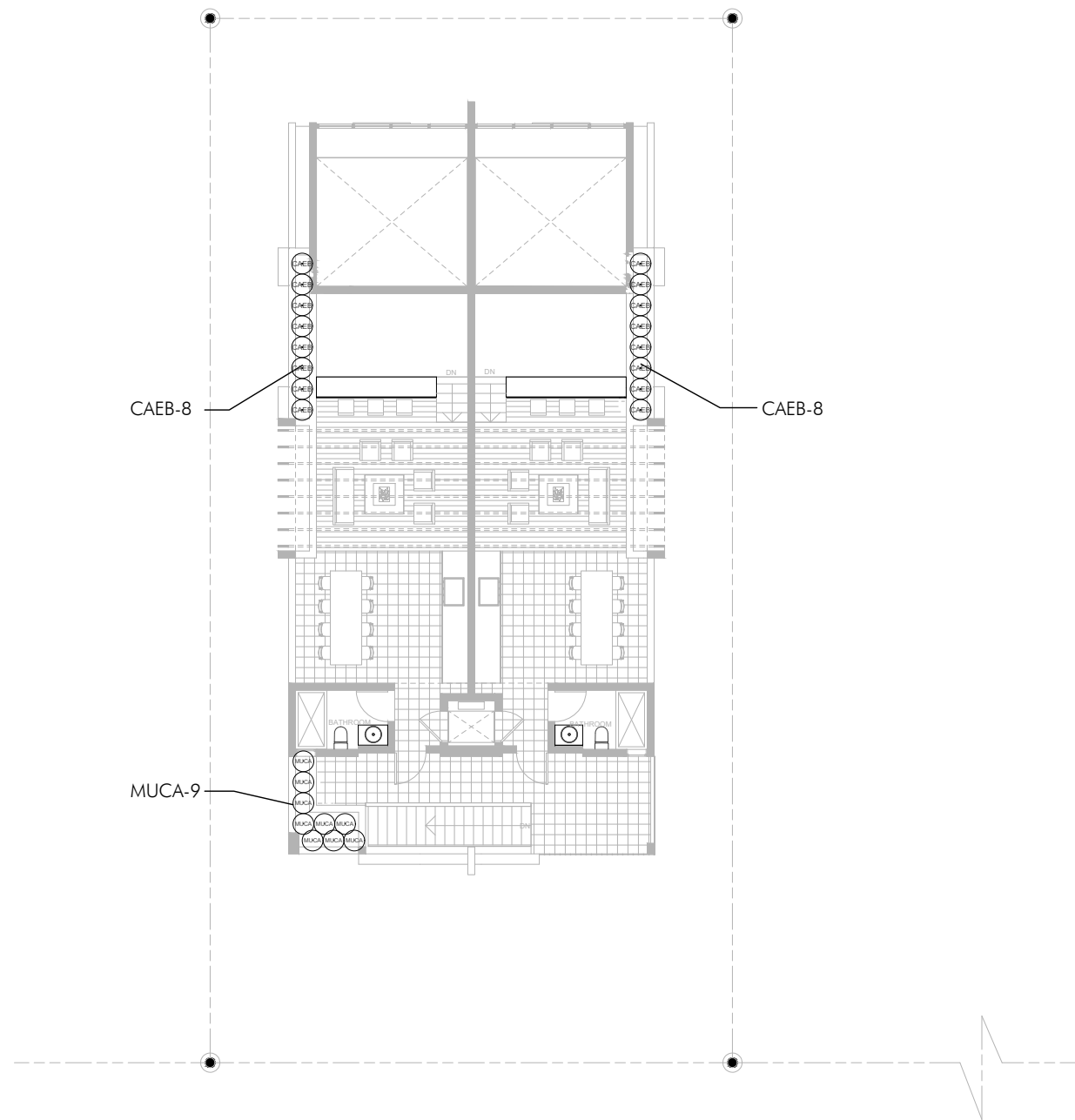

PLANT LIST - FOURTH FLOOR				
SHRUBS				
KEY	PLANT NAME	QTY.	UT.	SIZE
CAEB	Carissa macrocarpa "Emerald Blanket" ...Natal Plum	16	ea.	3 gallon cans, 18" spread
MUCA	Muhlenberghia cappillaris ...Muhly Grass	9	ea.	3 gallon cans, full
MISCELLANEOUS				
Green Roof Soil Mixes From Atlas Soil				
	Roof Planter Soil Mix 25% Coarse Sand 25% Medium Sand 20% Pine Bark 20% Florida Peat 8% Rice Rock 2% Marl	as req.	c.y.	
	Shredded Melaleuca Mulch	as req.	c.y.	3" layer in all shrub beds

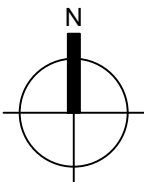

Roof Level Planting Plan

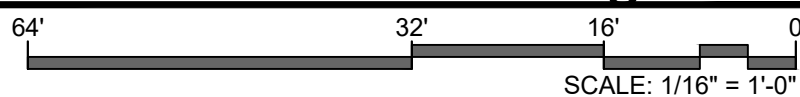

CASA LEROY
1339 14TH TERRACE MIAMI BEACH, FLORIDA 33139

MATEU ARCHITECTURE, INC.
8887 SW 131 STREET MIAMI, FLORIDA 33176

FIRST SUBMITTAL 04.29.2024

CITY OF MIAMI BEACH

LANDSCAPE LEGEND

INFORMATION REQUIRED TO BE PERMANENTLY AFFIXED TO PLANS

Zoning District: RM-1 Lot Area: 5,000 Acres: 0.11

	REQUIRED/ ALLOWED	PROVIDED
OPEN SPACE		
A. Square feet of required Open Space as indicated on site plan: Lot Area = <u>5,000</u> s.f. x 30% = <u>1500</u> s.f.	1,500	2,132
B. Square feet of parking lot open space required as indicated on site		
Number of parking spaces <u>0</u> x 10 s.f. parking space =	0	0
C. Total square feet of landscaped open space required: A+B=	1,500	1,987
LAWN AREA CALCULATION		
A. Square feet of landscaped open space required	N/A	N/A
B. Maximum lawn area (sod) permitted= <u>30%</u> x <u>5,000</u> s.f.	1,500	775
TREES		
A. Number of trees required per lot or net lot acre, less existing number of trees meeting minimum requirements= <u>28</u> trees x <u>0.11</u> net lot acres - number of existing trees=	4	4
B. % Natives required: Number of trees provided x 30% =	2	4
C. % Low maintenance / drought and salt tolerant required: Number of trees provided x 50%=	2	4
D. Street Trees (max. average spacing of 20' o.c.) <u>40</u> (Driveway excluded) linear feet along street divided by 20' =	2	2
E. Street tree species allowed directly beneath power lines: (max. average spacing of 20' o.c.): linear feet along street divided by	none	none
SHRUBS		
A. Number of shrubs required: Sum of lot and street trees req. x 12=	72	97
B. % Native shrubs required: Number of shrubs provided x 50%=	36	73
LARGE SHRUBS OR SMALL TREES		
A. Number of large shrubs or small trees required: Number of required shrubs x 10%=	8	13
B. % Native large shrubs or small trees required: Number of large shrubs or small trees provided x 50%=	4	13

Landscape Legend

SCALE: N.T.S.



CASA LEROY
1339 14TH TERRACE MIAMI BEACH, FLORIDA 33139
MATEU ARCHITECTURE, INC.
8807 SW 131 STREET MIAMI, FLORIDA 33176
TEL: 305.233.3304 FAX: 305.233.3326
FIRST SUBMITTAL 04.29.2024

LANDSCAPE SPECIFICATIONS

PART 1 - GENERAL

1.1 SCOPE

A. Contractor shall provide all labor, materials, equipment, supervision, and related work necessary to complete the landscape work in accordance with the intent of the landscape plans, schedules and these specifications. The extent of work is shown on the drawings which are a part of this document.

1.2 CONTRACTOR QUALIFICATIONS

A. Landscape installation work to be performed by a Contractor Certified by the Florida Nurserymen, Growers and Landscape Association (FNGLA) as a Certified Landscape Contractor. Any pruning to be supervised by an Arborist, certified by the International Society of Arboriculture (ISA) and licensed in County where work is performed.

1.3 INVESTIGATION OF UTILITIES

A. Prior to beginning work, the Contractor shall be responsible to locate existing underground utilities. Check with all utility companies and Sunshine State, call (811).

1.4 SUBSTITUTIONS

A. Only materials specified will be accepted, unless approved in writing by the Landscape Architect in advance.

1.5 PLANT SIZES

A. All plant sizes shall equal or exceed the minimum sizes as specified in the plant list. If plant sizes of local codes and ordinances require larger plant material than specified on plans, then they shall supercede the sizes on the plan. When plant sizes are specified as a range of size, installed materials shall average the mean of the range specified. Plants shall be measured following pruning, with branches in normal position. All necessary pruning shall be done at the time of planting.

1.6 PLANT QUALITY

A. All plant material shall be equal to or better than Florida No. 1 as classified by "Grades and Standards for Nursery Plants" by the Division of Plant Industry, Florida Department of Agriculture. They shall have a growth habit that is normal for the species; healthy, vigorous, free from insects, disease and injury.

B. The Owner or Landscape Architect reserves the right to refuse any plant material which does not conform to the intent of the written specifications or design.

C. CIRCLING ROOTS FOUND ON CONTAINER-GROWN MATERIAL WILL NOT BE ACCEPTED UNLESS REMEDIAL ROOT PRUNING, APPROVED BY THE LANDSCAPE ARCHITECT IS DONE BEFORE PLANTING.

1.7 PLANT QUANTITY

A. The plant quantities shown on the plant list are to be used only as an aid to bidders. In the case of discrepancy between the plant list and the plan, the quantity on the plan shall override the plant list.

1.8 UNIT PRICES

A. The successful bidder shall furnish to the Owner and the Landscape Architect, a unit price breakdown for all materials. The Owner may, at his discretion, add to or delete from the materials utilizing the unit price breakdown submitted to and accepted by the Owner.

1.9 SUBMITTALS

A. Fertilizer: The Contractor shall submit to the Owner and Landscape Architect documentation that all the fertilizer used for the project is of the analysis specified and placed at the rates specified in section 2.2 FERTILIZER.

B. Planting soil: The Contractor shall submit a sample of the planting soil (approximately 1 cu. Ft.) for approval by the Landscape Architect prior to delivery to the site.

1.10 CLEAN-UP & MAINTENANCE OF TRAFFIC

A. Follow procedures in FDOT Index 600 for maintenance of traffic during construction.

B. At the end of each work day, the Contractor shall remove debris and shall barricade the un-filled holes in a manner appropriate in the path of pedestrians and motorists.

C. Upon completion of the work or any major portion of the work or as directed by the Landscape Architect, all debris and surplus material from his work shall be removed from the job site.

1.11 MAINTENANCE PRIOR TO ACCEPTANCE

A. The Contractor is responsible to maintain the plantings until they are accepted under the provisions of 1.12 "ACCEPTANCE OF INSTALLATION".

1. Plants: Begin maintenance immediately following the final plant installation operation for each plant and continue until all plant installation is complete and accepted. Maintenance shall include watering all plants, weeding, mulching, pest and disease control, tightening and repairing of guys, repair of braces, removal of dead growth, resetting of plants to proper grade or up-right position, restoration of plant saucer, litter pick-up in plant beds and other necessary operations to assure specified minimum grade of Florida No. 1.

2. Turf Areas: Begin maintenance of turf immediately following the placement of sod and continue until sod installation is complete and accepted. Maintenance shall include but not be limited to, watering, leveling, mowing, weed and pest control, fungus and disease control and other necessary operations as determined by the Landscape Architect and good nursery practice.

3. Re-setting or straightening trees and palms:

The Contractor shall re-set and/or straighten trees and palms as required at no additional cost to the Owner unless caused by sustained winds of 75 mph or more. Then, the costs of the operations may be charged to the owner. Re-set trees within 48 hours.

1.12 ACCEPTANCE OF INSTALLATION

A. Inspection: Inspection of the work, to determine completion of contract work, exclusive of the possible replacement of plants and turf, will be made by the Landscape Architect at the conclusion of the maintenance period. Written notice requesting such an inspection and submitted by the Contractor at least ten (10) days prior to the anticipated date.

1.13 GUARANTEE

A. Guarantee all plants for a period of one year (CCD). Guarantee shall commence from the date of written acceptance. Plant material which is on the site and scheduled to be relocated is not covered by the guarantee except in the case of Contractor's negligence or work that has been done in an unworkman-like manner. The Contractor is not responsible for loss due to acts of god, (i.e.) sustained winds of 75 mph or more, floods, frost, lightning, vandalism or theft.

1.14 REPLACEMENT

A. Replacement shall be made during the guarantee period as directed by the Landscape Architect within ten (10) days from time of notification. For all replacement plant material, the guarantee period shall extend for an additional forty-five (45) days beyond the original guarantee period. The Contractor shall be responsible to provide water to the replacement plants in sufficient quantity to aid in their establishment. At the end of the guarantee period, inspection will be made by the Landscape Architect, upon written notice requesting such inspection and submitted by the Contractor at least five (5) days before the anticipated date. Replacement plants must meet the requirements of Florida No. 1 at time of inspection. Remove from the site all plants that are dead or in a state of unsatisfactory growth, as determined by the Landscape Architect. Replace these and any plants missing due to the Contractor's negligence as soon as conditions permit.

1. Materials and Operations: All replacement plants shall be of the same kind and size as indicated on the plant list. The Contractor shall supply and plant the plants as specified under planting operations.

2. Cost of Replacements: A sum sufficient to cover the estimated cost of possible replacements, including material and labor will be retained by the Owner and paid to the Contractor after all replacements have been satisfactorily made and approved by the Landscape Architect.

PART 2 - MATERIALS

2.1 PLANTING SOIL

A. Planting soil for trees, shrubs and ground covers shall be of the composition noted on the plans, measured by volume.

B. Soil for Sodded Areas: shall be coarse lawn sand.

2.2 FERTILIZER

A. Fertilizer for trees, palms, shrubs, and groundcovers shall be as follows: LESCO Palm Special 13-3-13 or equal, Sulfur coated with iron and other minor elements and maximum of 2% chlorine, or brand with equal analysis. The fertilizer shall be uniform in composition, dry and free flowing and shall be delivered to the site in the original unopened containers, bearing the manufacturer's guaranteed analysis. Fertilizer for sod and seeded areas shall be 8-6-8, 50% organically derived nitrogen, or equal.

2.3 WATER

A. The Contractor shall provide potable water on site, available from the start of planting. The Contractor is responsible to ascertain the location and accessibility of the water source. The Contractor is responsible to provide the means of distribution (i.e. water truck, hoses, etc.) for distribution of water to the planting areas.

2.4 MULCH

A. Mulch shall be as specified on the Plant List.

2.5 ROOT BARRIER MATERIAL

A. Root barrier material shall be 24" deep polypropylene panels by DeepRoot or approved equal.
B. Install per details in the plans.

PART 3 - INSTALLATION PROCEDURES

3.1 LAYOUT

A. Verify location of all underground utilities and obstructions prior to excavation.

3.2 HERBICIDE TREATMENT

A. In all areas infected with weed and/or grass growth, a systemic herbicide shall be applied per manufacturer's rates. When it has been established where work will be done, the systemic herbicide shall be applied in accordance with manufacturer's labeling to kill all noxious growth. Contractor shall schedule his work to allow more than one application to obtain at least 95% kill of undesirable growth. If necessary, Contractor shall conduct a test to establish suitability of product and applicator to be used on this project, prior to execution of the full application.

3.3 PLANT PIT EXCAVATION AND BACKFILLING

A. Trees: See the Planting and Bracing Details and notes.

B. All planting holes shall be hand dug where machine dug holes may adversely affect utilities or improvements.

C. Shrubs and Groundcover: Shrubs and groundcover shall be planted in a soil bed as described in the notes and details. Space shrubs and provide setback from curb and pavements as shown in the plans.

D. Watering of field-grown plants: Thoroughly puddle in water to remove any air pockets in the plant hole.

3.4 WATERING

A. The Contractor is responsible to provide the water for all new plants and transplants and means of distribution (i.e. hand watering or water truck) during the maintenance period and extending into the period after acceptance until the full schedule as listed below is complete. Water for trees and other large field grown plants shall be supplemented by hand or water truck, in addition to the irrigation system, (if one is provided). Contractor can adjust watering schedule during heavy rain season upon approval of the Landscape Architect.

AMOUNT OF WATER PER APPLICATION

For trees up to 5 inch caliper - 5 gallons

From 5 to 8 inch caliper - 25 gallons

9 inch and up caliper - 50 gallons

FREQUENCY OF WATER

Daily for the first week

3 times per week for weeks 2 - 5

2 times per week for weeks 6 - 8

1 time per week for weeks 9 - 12

B. Water in plants by thoroughly soaking of the entire root ball immediately after planting. For large trees and shrubs, add water while backfilling hole to eliminate any air pockets in the soil around the root ball.

C. Water shrubs, sod and groundcover a minimum of once daily for a week or until an irrigation system is fully operational. If no irrigation system is to be installed, the Contractor shall be responsible for watering the shrub, sod, and groundcover for the time specified above, after installation of each section of the planting installed.

Landscape Specifications

SCALE: N.T.S.



GARDNER + SEMLER
LANDSCAPE ARCHITECTURE
WWW.GSLDESIGN.COM
17470 NW 78th AVE., SUITE 214
MIAMI, FL 33157
P 305.392.1010 F 305.392.1019
CORP. ID # 0000266

CASA LEROY

1330 14TH TERRACE MIAMI BEACH, FLORIDA

MATEU ARCHITECTURE, INC.

8887 SW 131 STREET
TEL: 305.233.3304
FAX: 305.233.3326

MIAMI, FLORIDA

FIRST SUBMITTAL

33139

33176

04.29.2024

3.5 FERTILIZING

A. Add fertilizer on top of the surface of shrubs beds and tree and palms root balls two (2) months after installation. Fertilize sod within two (2) days after installing after planting of each segment of the job. Fertilizer shall be applied after soil has been well moistened. Fertilizer shall be washed off of plant leaves and stems immediately after application. Apply at the following rates:

1. Trees and Large Shrubs: One (1) pound per inch of trunk diameter, spread evenly over the root ball area.
2. Shrubs: One half (1/2) handful per shrub, spread evenly over the root ball area.
3. Groundcover: Twelve (12) pounds per 100 sq. ft. of bed area.
4. Sod: Twelve (12) pounds per 1,000 sq. ft. Wash fertilizer off blades immediately after spreading.

3.6 MULCHING

A. Spread mulch three (3) inches thick uniformly over the entire surface of shrubs and groundcover beds, depth measured after settling, unless otherwise specified in the plans. Provide 36" diameter bed of mulch, measured from outer edge of the trunk, for all trees and palms planted in sod areas. Keep mulch away from contact with the trunk. Create a 6" high ring of mulch at the outer edge of tree and palm holes.

3.7 GUYING AND BRACING

A. See the details bound herewith or made part of the plans.

3.8 SODDING

- A. Provide a blanket of lawn sand as described in the notes in these plans. Prior to planting, remove stones, sticks, etc. from the sub-soil surface. Excavate existing non-conforming soil as required so that the finish grade of sod is flush with adjacent pavement or top of curb as well as adjacent sod in the case of sod patching.
- B. Place sod on moistened soil, with edges tightly butted, in staggered rows at right angles to slopes. The sod shall be rolled with a 500 pound hand roller immediately after placing.
- C. Keep edge of sod bed a minimum of 18" away from groundcover beds and 24" away from edge of shrub beds and 36" from trees, measured from the edge of plant or tree trunk.
- D. Sod shall be watered immediately after installation to uniformly wet the soil to at least two inches below the bottom of sod strips.
- E. Apply fertilizer to the sod as specified in Section 3.5.
- F. Excavate and remove excess soil so top of sod is flush w/top of curb or adjacent pavement, or adjacent existing sod.

PLANT BED PREPARATION NOTES

1. In all areas where new sod and shrub and groundcover masses are to be planted, kill all existing weeds by treating with systemic herbicide prior to beginning soil preparation.
2. In all shrub and groundcover beds, excavate and backfill soil as described in "Plant List(s)". If no specific preparation is noted, prepare soil as described below for either condition, over the entire area to be planted:

Condition A:

If any compacted road base or asphalt or rocky soil is encountered, remove compacted material entirely to allow an 18" depth of planting soil per plant list unless otherwise stated. Backfill the entire area of the shrub and groundcover beds with 18" planting soil (as specified in Plans) to within 2 inches of the adjacent pavement or top of curb. Remove all debris and rocks and pebbles larger than 2 inches in size and level the grade before planting.

Condition B:

Where no compacted soil is encountered, thoroughly mix 6 inches of planting soil per plant list into the existing soil to a depth of 18 inches unless otherwise stated. If required, excavate and remove the existing soil to lower the grade, so that the prepared mix is finished to a minimum of 2 inches below top of curb or adjacent walkway. Remove all debris and rocks and pebbles larger than 2 inches in size and level the grade before planting.

For all sod areas, spread a 2" deep layer of lawn sand prior to sodding. Remove all debris and rocks and pebbles larger than 2 inches in size and level the grade before sodding. Remove, if required, existing soil so that top of sod is flush with and adjacent top of curb or pavement.

For Trees and shrubs larger than 7 gallon, Add Diehard" transplant innoculant supplied by Horticultural Alliance, Inc. (800-628-6373) or equal. Mix into top 8-10 inches of planting hole, making sure it is contact with the root ball. Add at a rate specified by manufacturer (typically 4oz. per 1 inches of trunk caliper or 7 gallon can).

SPACING OF PLANTS (SEE PLANT SPACING DETAIL)

1. Plants shall be planted sufficiently away from edges of pavements or curbs, to allow for growth toward the edges of the bed.

PROTECTION OF PLANTS

1. The Contractor shall be responsible to protect existing trees and shrubs in and adjacent to the area of work. Erect barriers as necessary to keep equipment and materials, any toxic material, away from the canopy drip line of trees and shrubs. DO NOT PILE SOIL OR DEBRIS AGAINST TREE TRUNKS OR DEPOSIT NOXIOUS BUILDING SUPPLIES OR CHEMICALS WITHIN THE DRIP LINE.

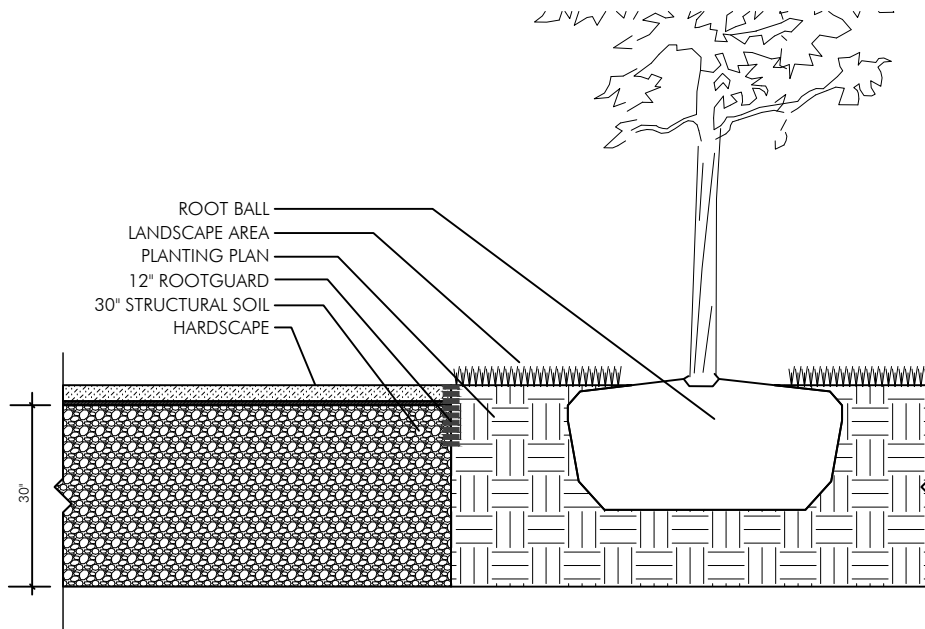

STRUCTURAL SOIL DETAIL (TYP.)

N.T.S.

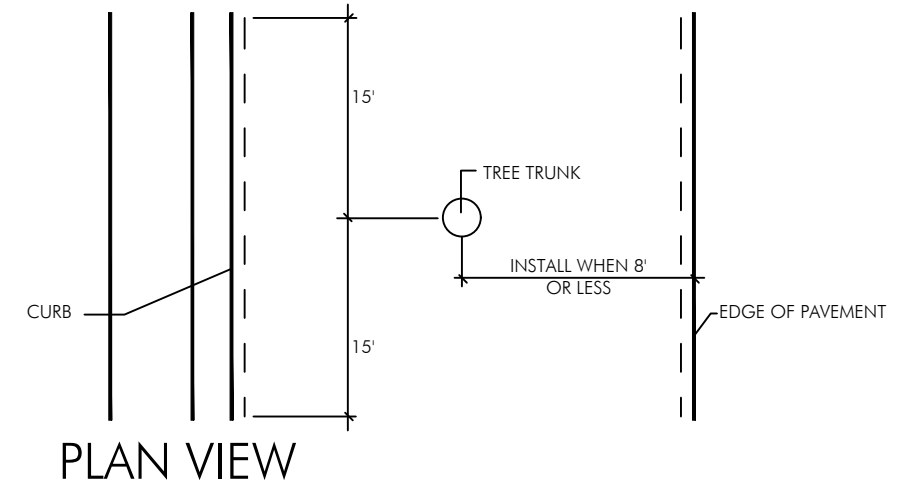

PLAN VIEW

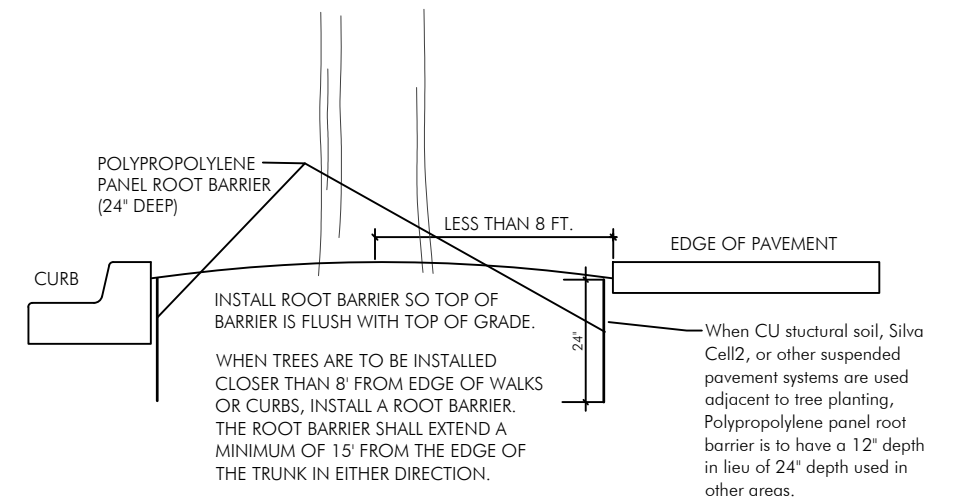

ROOT BARRIER INSTALLATION DETAIL

N.T.S.

Landscape Specifications & Planting Details

SCALE: N.T.S.

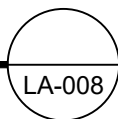

GARDNER + SEMLER
LANDSCAPE ARCHITECTURE
WWW.GSLADESIGN.COM
DESIGN
17470 NW 78th AVE., SUITE 214
MIAMI, FL 33157
P 305.392.1010 F 305.392.1019
CORP. 10/000200

CASA LEROY
1339 14TH TERRACE MIAMI BEACH, FLORIDA 33139
MATEU ARCHITECTURE, INC.
8887 SW 151 STREET MIAMI, FLORIDA 33176
TEL: 305.233.3304
FAX: 305.233.3308
FIRST SUBMITTAL 04.29.2024

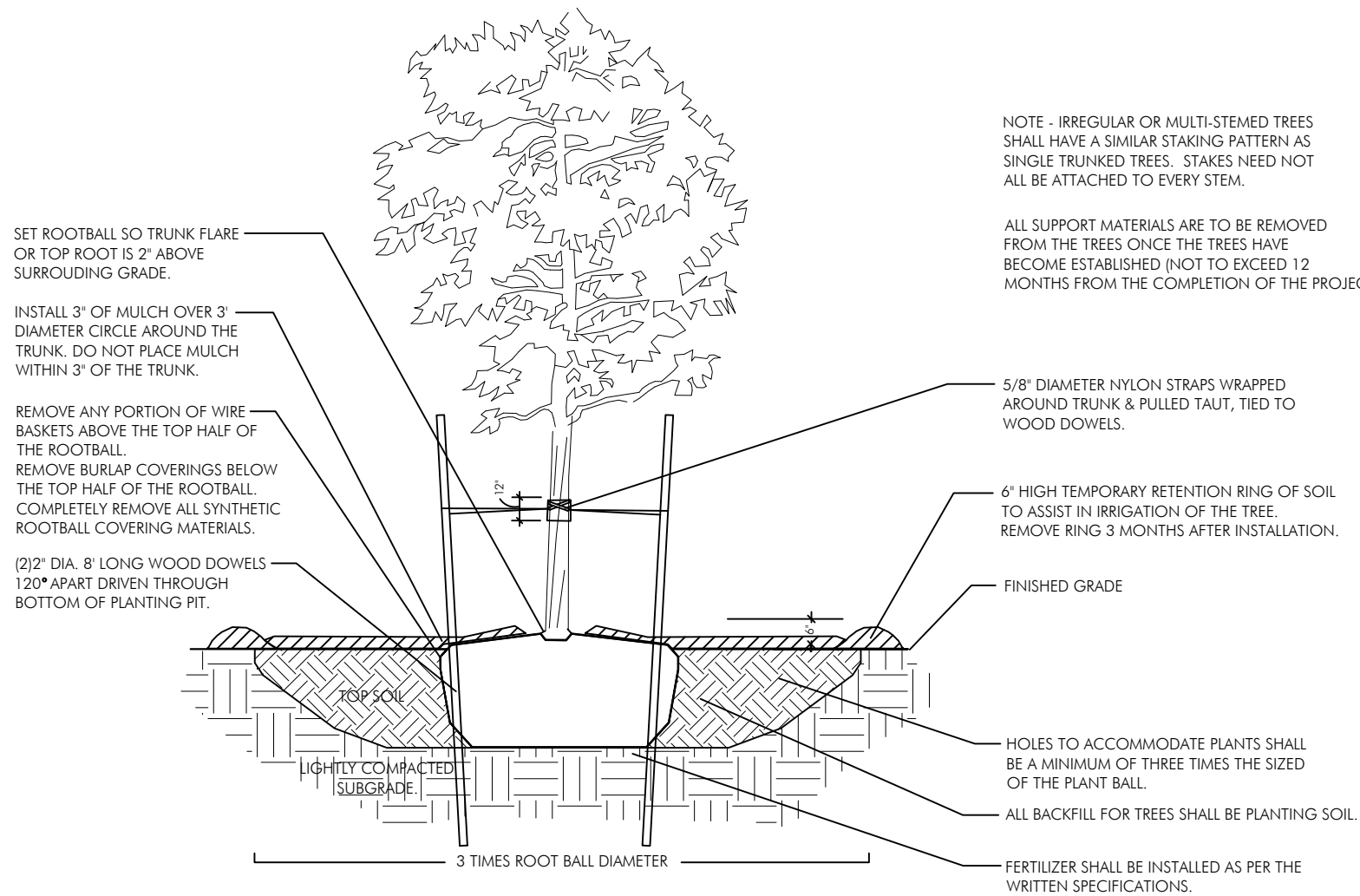

PLANTING & BRACING DETAIL UNDER 3 1/2" CALIPER

N.T.S.

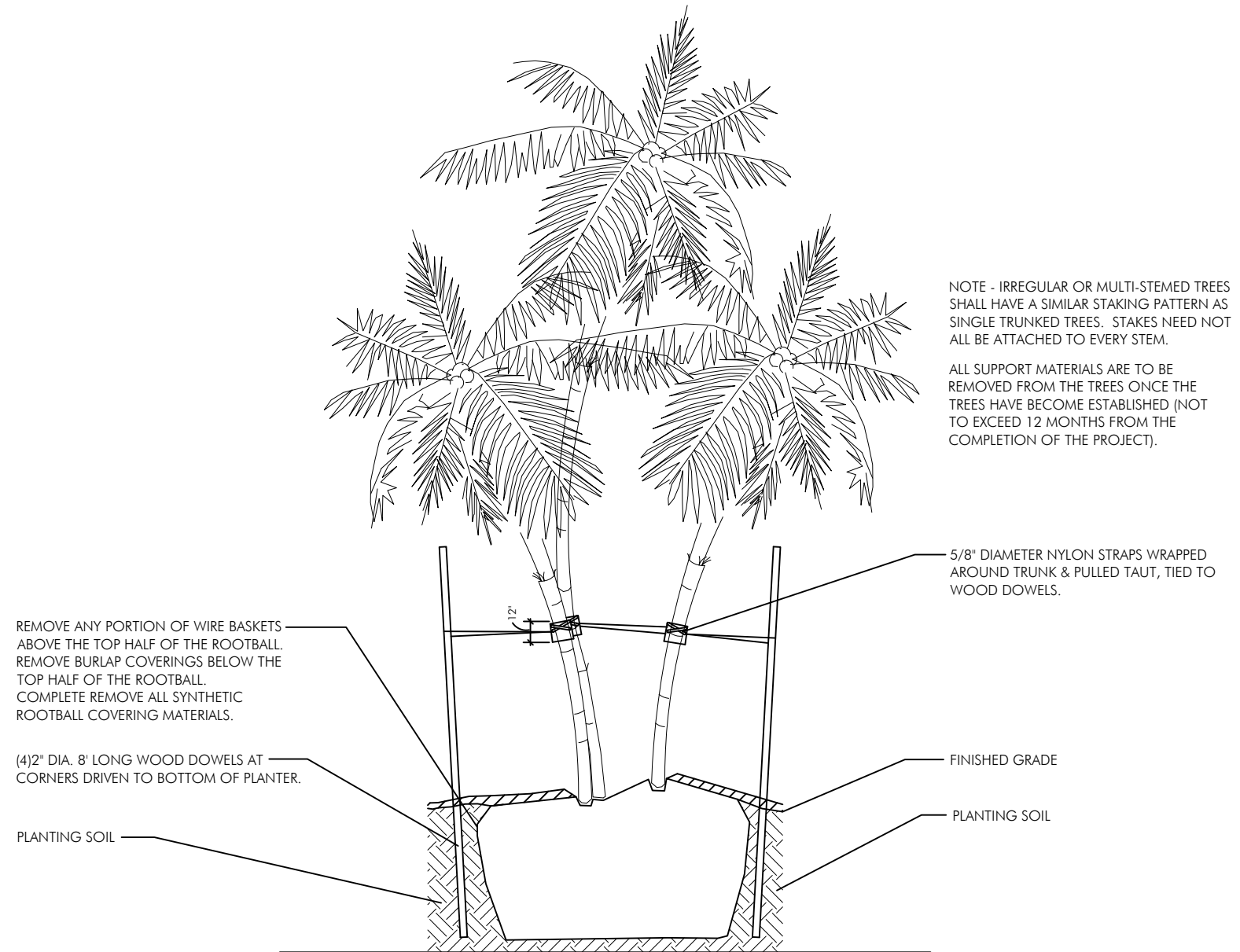

MULTI-TRUNKED TREE/PALM BRACING DETAIL

N.T.S.

Planting Details

SCALE: N.T.S.

LA-009



CASA LEROY
1339 14TH TERRACE MIAMI BEACH, FLORIDA 33139

MATEU ARCHITECTURE, INC.
8887 SW 131 STREET MIAMI, FLORIDA 33176

TEL: 305.233.3304
FAX: 305.233.3308

FIRST SUBMITTAL 04.29.2024

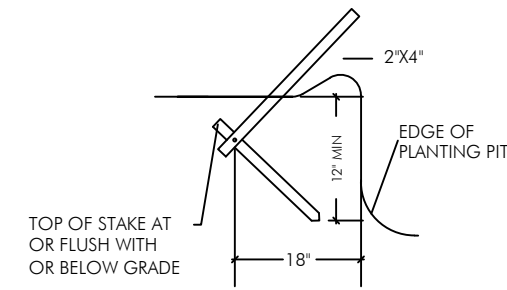

DETAIL A

N.T.S.

NOTE - USE 4" X 4" STAKES PALMS OVER 12" CALIPER.

PROVIDE FOUR 2" X 4" PINE STAKES 120° APART. ATTACH W/ NAILS TO BATTENS NO NAILS IN TREE.

SET ROOTBALL SO TRUNK FLARE OR TOP ROOT IS 2" ABOVE SURROUNDING GRADE.

INSTALL 3" OF MULCH OVER 3" DIAMETER CIRCLE AROUND THE TRUNK. DO NOT PLACE MULCH WITHIN 3" OF THE TRUNK.

REMOVE ANY PORTION OF WIRE BASKETS OR BURLAP ABOVE THE TOP HALF OF THE ROOTBALL. FOLD BACK BURLAP COVERINGS BELOW THE TOP HALF OF THE ROOTBALL. COMPLETELY REMOVE ALL SYNTHETIC ROOTBALL COVERING MATERIALS.

DETAIL A

WOOD STAKES TOP OF STAKES BELOW OR FLUSH WITH GRADE.

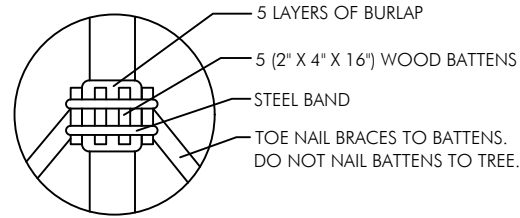

BATTEN DETAIL B

N.T.S.

NOTE - SECURE BATTENS WITH 2-3/4" HI CARBON STEEL BANDS TO HOLD BATTENS IN PLACE DURING PLANTING PROCESS. DO NOT NAIL BATTENS TO TREE. THE HEIGHT OF THE BATTENS SHALL BE LOCATED IN RELATION TO THE HEIGHT OF THE TREE FOR ADEQUATE BRACING. PAINT ALL EXPOSED WOOD SURFACES, (COLOR TO BE APPROVED BY LANDSCAPE ARCHITECT).

NOTE - IRREGULAR OR MULTI-STEMED TREES SHALL HAVE A SIMILAR STAKING PATTERN AS SINGLE TRUNKED TREES. STAKES NEED NOT ALL BE ATTACHED TO EVERY STEM.

ALL SUPPORT MATERIALS ARE TO BE REMOVED FROM THE TREES ONCE THE TREES HAVE BECOME ESTABLISHED (NOT TO EXCEED 12 MONTHS FROM THE COMPLETION OF THE PROJECT).

6" HIGH TEMPORARY RETENTION RING OF SOIL TO ASSIST IN IRRIGATION OF THE TREE. REMOVE RING 3 MONTHS AFTER INSTALLATION.

FINISHED GRADE

HOLES TO ACCOMMODATE PLANTS SHALL BE A MINIMUM OF THREE TIMES THE SIZED OF THE PLANT ROOTBALL.

ALL BACKFILL FOR TREES SHALL BE PLANTING SOIL

FERTILIZER SHALL BE INSTALLED AS PER THE WRITTEN SPECIFICATIONS.

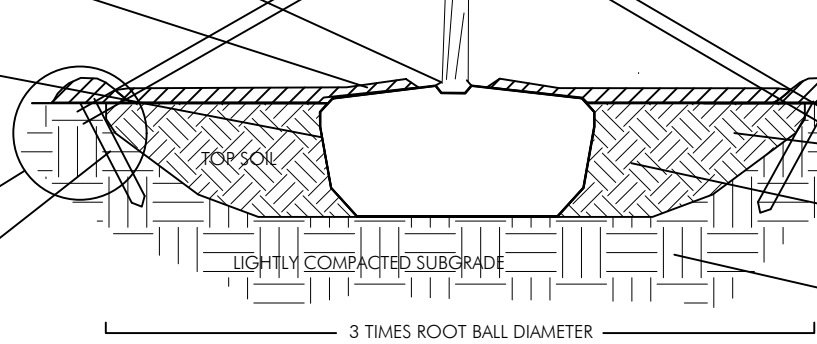

PLANTING & BRACING DETAIL OVER 3 1/2" CALIPER

N.T.S.

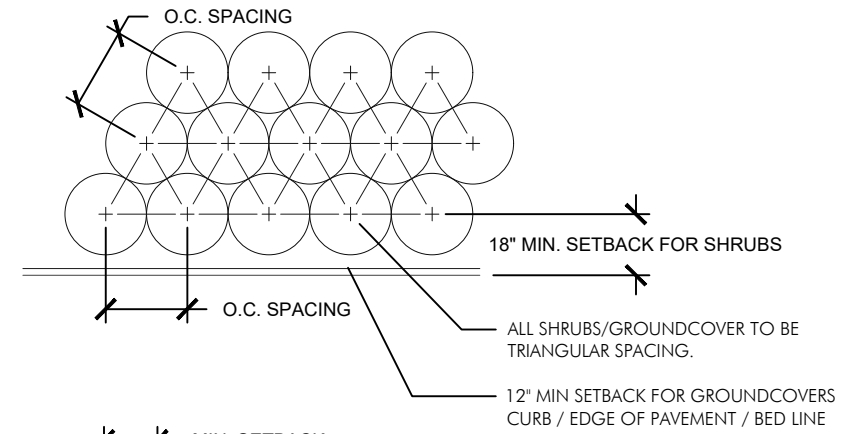

PLANT SPACING DETAIL

N.T.S.

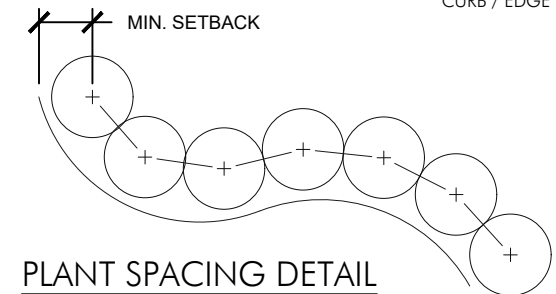

NOTE: THE PERIMETER OF ALL CURVED PLANTING BEDS SHALL BE PLANTED WITH ROW OF SHRUBS AS SHOWN IN THE PLANT AND AT THE SPACING SHOWN IN THE PLANT LIST. INTERIOR PORTIONS OF EACH BED SHALL BE PLANTED AT APPROPRIATE SPACING ACCORDING TO THIS PLANT SPACING DETAIL.

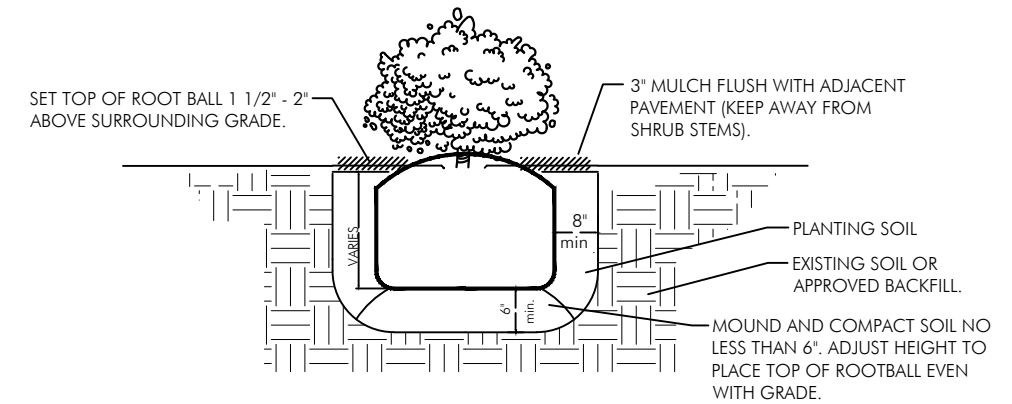

SHRUB INSTALLATION DETAIL

N.T.S.

Planting Details

SCALE: N.T.S.

LA-010



GARDNER + SEMLER
LANDSCAPE ARCHITECTURE
WWW.GSLDESIGN.COM
17470 NW 78th AVE., SUITE 214
MIAMI, FL 33157
TEL: 305.233.3304
P: 305.392.1016 F: 305.392.1019
CORP. 10#0000266

CASA LEROY
1339 14TH TERRACE MIAMI BEACH, FLORIDA 33139
MATEU ARCHITECTURE, INC.
8887 SW 131 STREET MIAMI, FLORIDA 33176
TEL: 305.233.3304
FAX: 305.233.3308
FIRST SUBMITTAL 04.29.2024

IRRIGATION MATERIALS LIST

KEY	ITEM	QTY.
	RAINBIRD Spray Heads 1800 @ 30 PSI	as required
	Series w/MPR nozzles	
	6" pop-up in grass areas	
	12" pop-up on risers in shrub beds	
●	15-F (3.7 gpm)	
◐	15-TQ (2.78 gpm)	
◑	15-H (1.85 gpm)	
◒	15-T (1.23 gpm)	
◓	15-Q (.92 gpm)	
◔	15-sst (1.21 gpm)	
◕	15-cst (1.21 gpm)	
◖	15-est (.61 gpm)	
◗	9-sst (1.73 gpm)	
○	10-F (1.58 gpm)	
◌	10-TQ (1.18 gpm)	
◍	10-H (.79 gpm)	
◎	10-T (.53 gpm)	
●	10-Q (.39 gpm)	

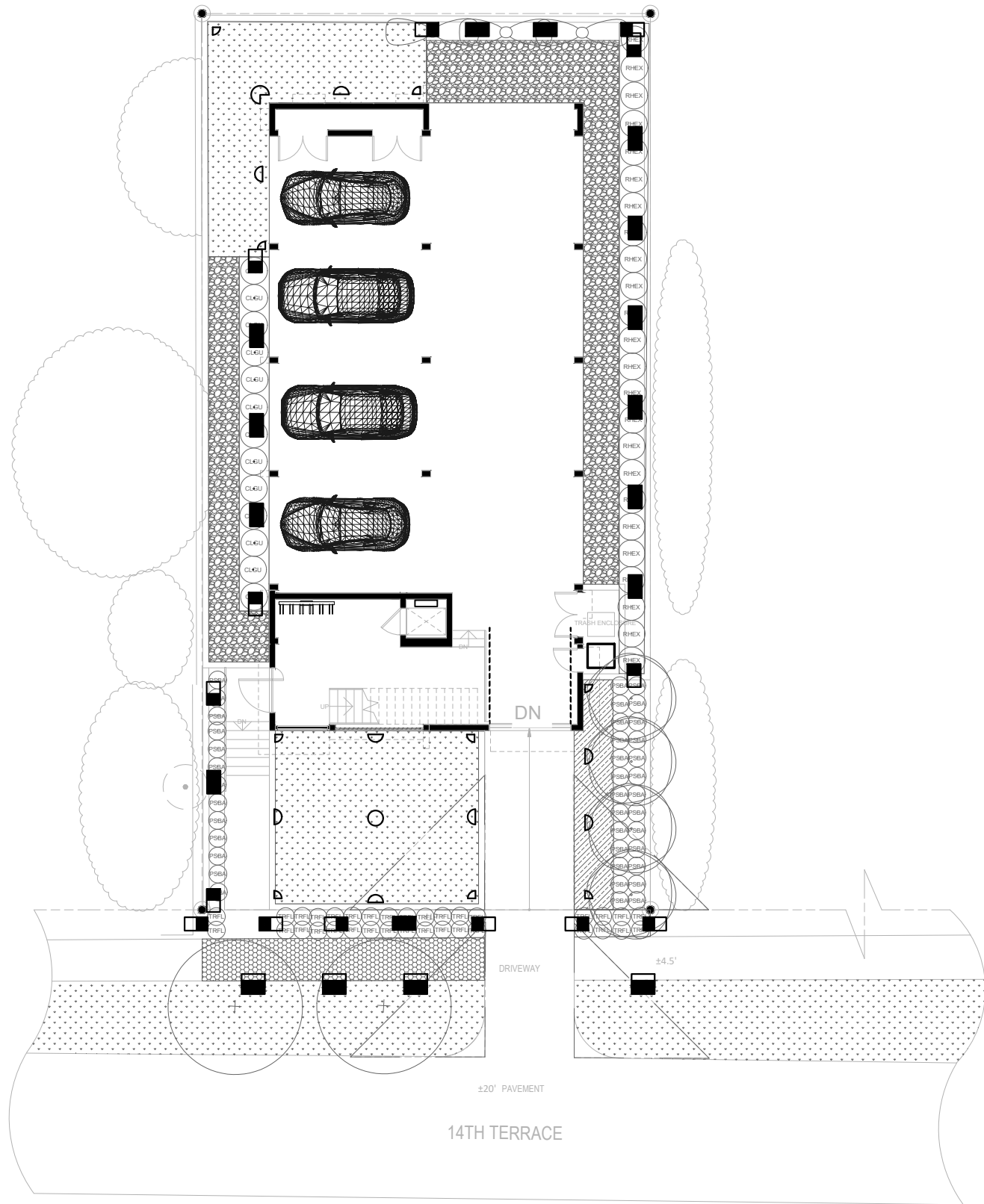

*NOTES:

-All main, lateral, and valve locations are shown schematically and shall be adjusted in the field. Locate mains and laterals in landscape areas (preferably at edges of curbs or walks.)

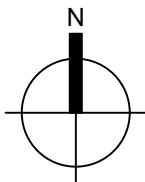

Ground Floor Irrigation Head Layout Plan

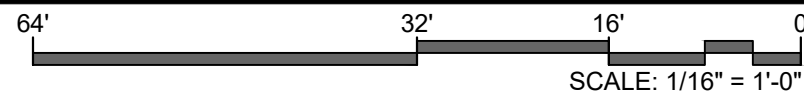

LA-011



CASA LEROY
1339 14TH TERRACE MIAMI BEACH, FLORIDA 33139
MATEU ARCHITECTURE, INC.
8887 SW 131 STREET
TEL.: 305.233.3304 F.L. 2-3-0-1-2
FAX: 305.233.3308 P. 305.392.1016 F. 305.392.1019
CORP. 1-D #0000266
FIRST SUBMITTAL
04.29.2024

IRRIGATION MATERIALS LIST

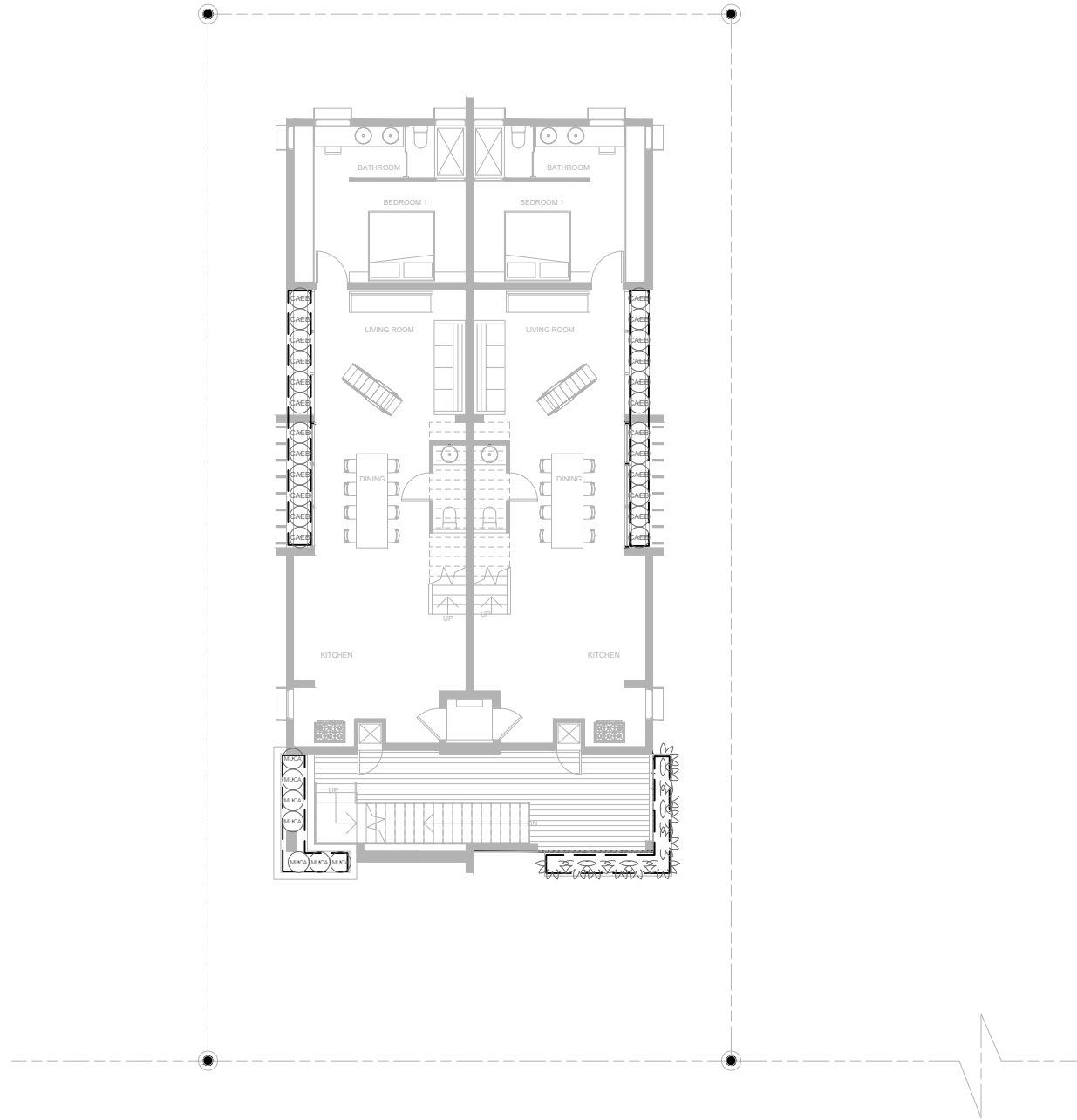

KEY

ITEM

- RAINBIRD XFS Subsurface Dripperline
XFS-09-12-500/250/100
- Air/Vacuum Relief Valves Kit (3/4" Air relief valve/
Easy Fit Compression Tee/ and Flush Cap)

***NOTES:**

-All main, lateral, and valve locations are shown schematically and shall be adjusted in the field. Locate mains and laterals in landscape areas (preferably at edges of curbs or walks.)

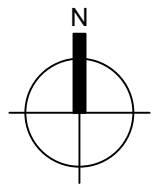

Second Floor Drifterline Layout Plan

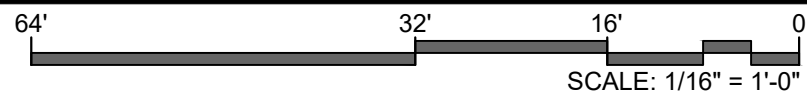

LA-012



CASA LEROY
1339 14TH TERRACE MIAMI BEACH, FLORIDA 33139
MATEU ARCHITECTURE, INC.
8887 SW 131 STREET MIAMI, FLORIDA 33176
TEL: 305.233.3304
FAX: 305.233.3308
FIRST SUBMITTAL 04.29.2024

IRRIGATION MATERIALS LIST

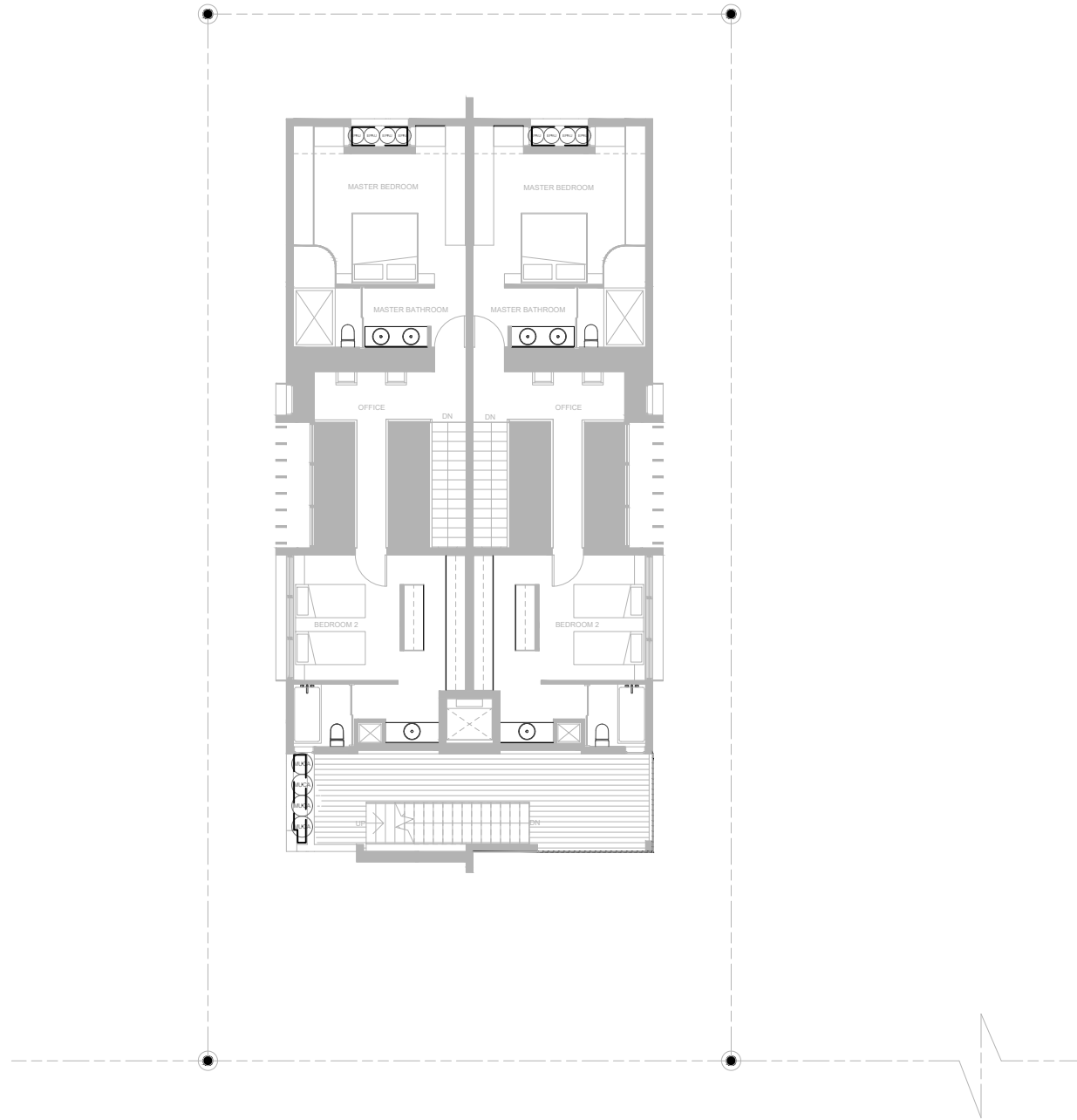

KEY ITEM

- RAINBIRD XFS Subsurface Dripperline
XFS-09-12-500/250/100
- Air/Vaccum Relief Valves Kit (3/4" Air relief valve/
 Easy Fit Compression Tee/ and Flush Cap)

***NOTES:**

-All main, lateral, and valve locations are shown schematically and shall be adjusted in the field. Locate mains and laterals in landscape areas (preferably at edges of curbs or walks.)

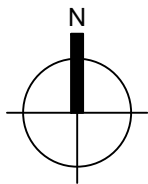

Third Floor Dripperline Layout Plan

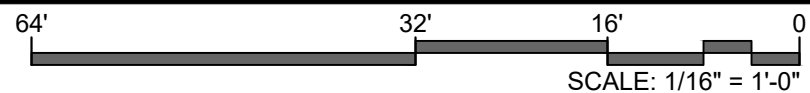

LA-013



CASA LEROY
1339 14TH TERRACE MIAMI BEACH, FLORIDA 33139
MATEU ARCHITECTURE, INC.
8887 SW 131 STREET MIAMI, FLORIDA 33176
TEL: 305.233.3304
FAX: 305.233.3308
FIRST SUBMITTAL

04.29.2024

IRRIGATION MATERIALS LIST

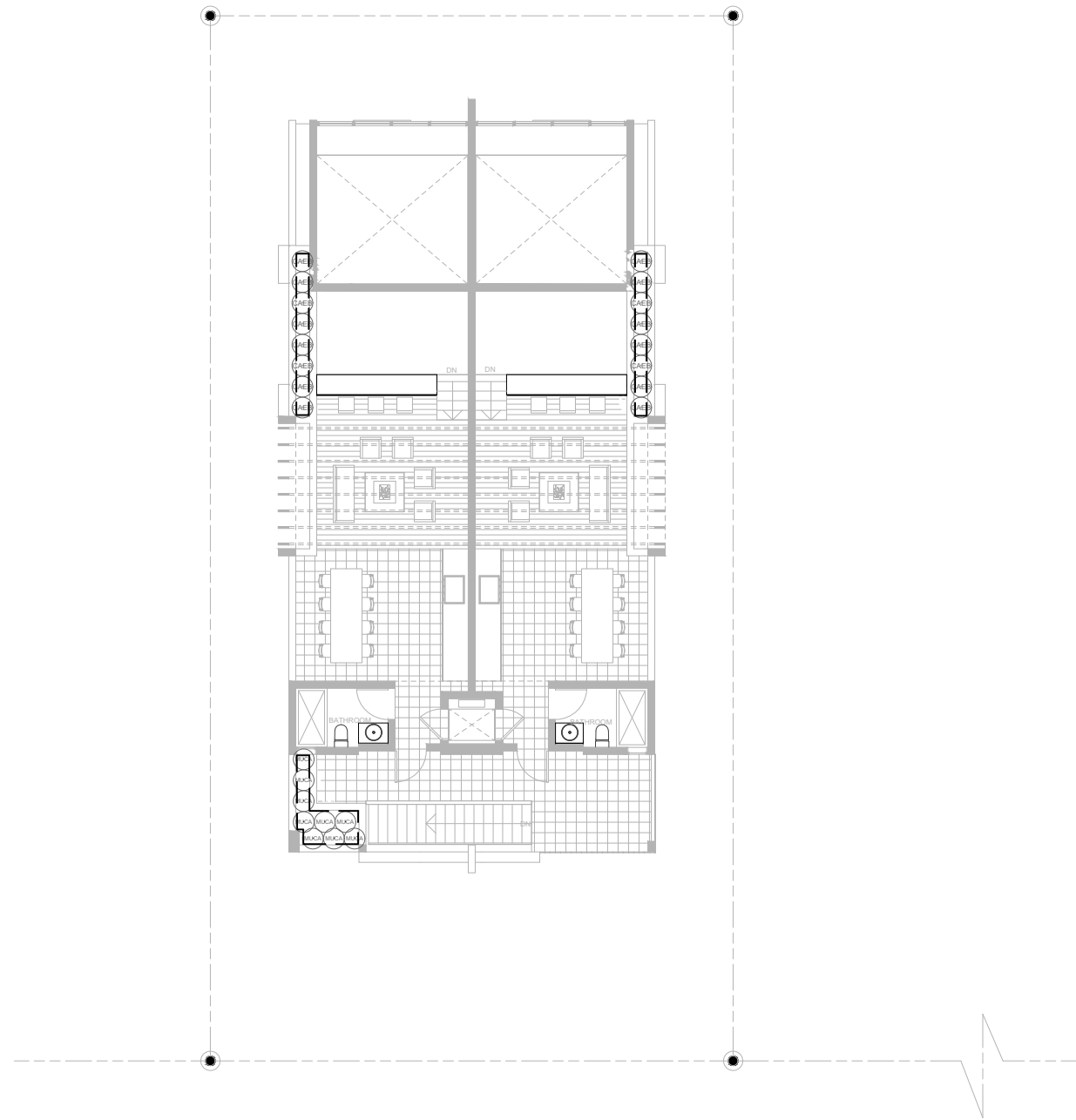

KEY

ITEM

- RAINBIRD XFS Subsurface Dripperline
XFS-09-12-500/250/100
- Air/Vaccum Relief Valves Kit (3/4" Air relief valve/
Easy Fit Compression Tee/ and Flush Cap)

***NOTES:**

-All main, lateral, and valve locations are shown schematically and shall be adjusted in the field. Locate mains and laterals in landscape areas (preferably at edges of curbs or walks.)

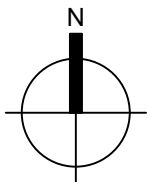

Roof Level Dripperline Layout Plan

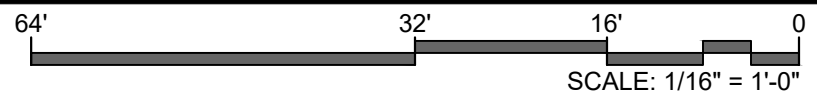

LA-014



GARDNER + SEMLER
LANDSCAPE ARCHITECTURE
WWW.GSLDESIGN.COM
17470 NW 78th AVE., SUITE 214
MIAMI, FL 33157
P: 305.392.1016 F: 305.392.1019
CORP. 10000266

CASA LEROY
1339 14TH TERRACE MIAMI BEACH, FLORIDA 33139
MATEU ARCHITECTURE, INC.
8887 SW 131 STREET MIAMI, FLORIDA 33176
TEL: 305.233.3304
FAX: 305.233.3308
FIRST SUBMITTAL 04.29.2024

GENERAL NOTES:

1. **SCOPE OF WORK:** The Contractor shall furnish all labor, machinery, tools, supplies, and equipment as necessary to construct and provide an operating system, as indicated in the Plans. The work shall include, but not be limited to, furnishing materials (pipe, valves, sprinkler heads, fittings, controllers, electrical, wire and fittings, primer, glue, etc.), layout, protection to the public, excavation, assembly, installation, backfilling, compaction, repair of road or pavement surfaces, controller and low voltage feed to the valves, clean-up, maintenance and guarantee, and as-built plans.

2. Contractor shall coordinate with General Contractor or other pertinent Contractors on the job to insure that sleeves are provided and installed under hard surfaces to allow access to all areas to be irrigated. All sleeves shall be constructed of Class 200 PVC. Bury all sleeves a minimum of 18" below the surface. Sleeve to be double the size if the pipe running through it. Sleeve shall extend 24" past the edge of pavement into the area to be irrigated.

3. **GUARANTEE:** The irrigation system shall be guaranteed for a minimum of one calendar year from the time of final acceptance.

4. **REPAIR UTILITIES:** The Contractor shall be responsible to verify the location of all utilities by hand excavation or other appropriate measures before performing any work that may result in damage to utilities structures, or property. The Contractor shall take immediate steps to repair, replace, or restore all services to any utilities which are disrupted due to his operations. All costs involved in disruption of service and repairs due to negligence on part of the Contractor shall be his responsibility.

5. **AS-BUILT DRAWINGS:** Prints of the plans will be supplied to the Contractor for recording "as-built" information. Immediately upon installation of any work which deviates from what is shown on the Plans, the Contractor shall clearly indicate such changes in red pencil on the prints. Such changes shall include, but not be limited to, changes in (1) materials; (2) sizes of material; (3) location; and (4) quantities.

6. The entire installation shall fully comply with all applicable local and state codes and ordinances. The Contractor shall take out all required plumbing and electrical applications and permits, arrange for all necessary inspections and shall pay all fees and expenses in connection with same as part of work under the contract.

7. **UNIT PRICES:** The successful bidder shall furnish, to the Owner, a unit price breakdown for all materials. The Owner may at his own discretion, add to or delete from the materials, using the unit price breakdown submitted to and accepted by the Owner.

8. **MAINTENANCE PERIOD:** The irrigation system shall be maintained for a period of 90 days after final acceptance of installation. Maintenance shall include checking of the system 2 times per week. Contractor shall be responsible to replace/repair any broken or malfunctioning parts of the system including those damaged by accidents or vandalism. Repairs shall be made immediately at the time of inspection or when notified by the Landscape Architect.

9. The irrigation system shall provide 100% coverage with a minimum of 90% overlap of water spray.

10. The system is design to provide sprinkler precipitation rates that are nearly equal in each zone. Mixing of sprinklers with widely varying precipitation rates in a zone will not be accepted.

11. Irrigation mainline shall be made of Class 200 PVC and all laterals shall be Class 200 PVC, except flexible PVC (or Toro funny pipe) for flexible swing joint and Schedule 40 PVC risers for spray heads in shrub areas. Schedule 80 galvanized steel pipe is to be used for all above ground fittings. Pipe locations shall be adjusted in the field. When laying out mains and laterals, locate pipe near edges of pavement or against buildings wherever possible, to allow space for plant rootballs. Coordinate pipe locations with plantings. Bury all mains and laterals 18" min. below surface. Depth shall be measured to top of pipe.

12. Keep pop-up sprinkler heads a minimum of 8" from edges of pavement and curbing, and heads on risers a minimum of 18", or as indicated in the pans.

13. All heads located in shrub or groundcover beds shall be installed on a riser as per details in the plans. All other heads shall be installed on a swing joint as per details in the plans.

14. Place irrigation control wire in conduit in the same trench as mains and under the main. ASI wire shall be #14 or larger solid copper U.L. approved underground direct burial cable and shall be continuous with no splices from controller to solenoid valve.

15. Valve locations are schematic and shall be adjusted in the field. Each valve shall be in a separate valve box (10" x 16" min.). When grouping valve boxes in grass or groundcover areas, set boxes a minimum of 12" apart to allow grass or groundcover to grow between them. When possible, hide valve boxes in shrub beds, a minimum of 12" from edge of beds. Set all valve boxes, concrete or plastic, in ground with cover flush with finish grade, and level, with a minimum of 6" of pea gravel at the bottom of the box, with at least 2" of clearance from the bottom of the valve to the top of the gravel.

16. **TESTING:** Notify the Landscape Architect in writing when testing will be conducted. Conduct test in the presence of the Landscape Architect. After all PVC assembly is completed the lines shall be flushed to insure that no rocks, sand, or other foreign debris remains in the lines. The mains shall be filled with water and all outlets shall be capped and plugged. The main shall be pressurized to 100 PSI for a minimum of one hour. No section of the main will be approved if the pressure drops more than 5 PSI at the end of the one hour period. Leaks shall be repaired immediately and the system shall be re-tested until found satisfactory by the Landscape Architect.

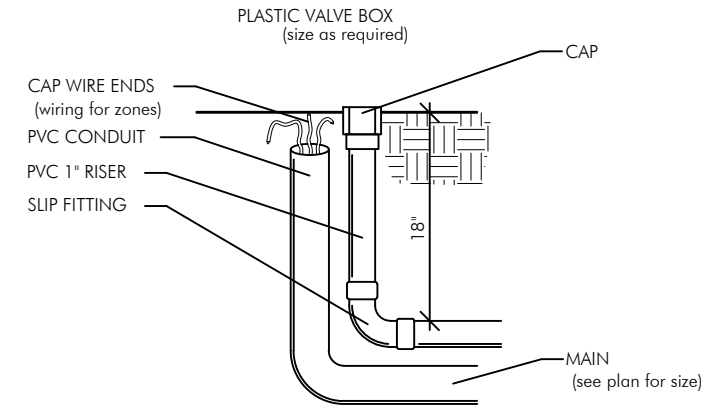

DETAIL OF STUB-OUT FOR FUTURE USE

N.T.S.

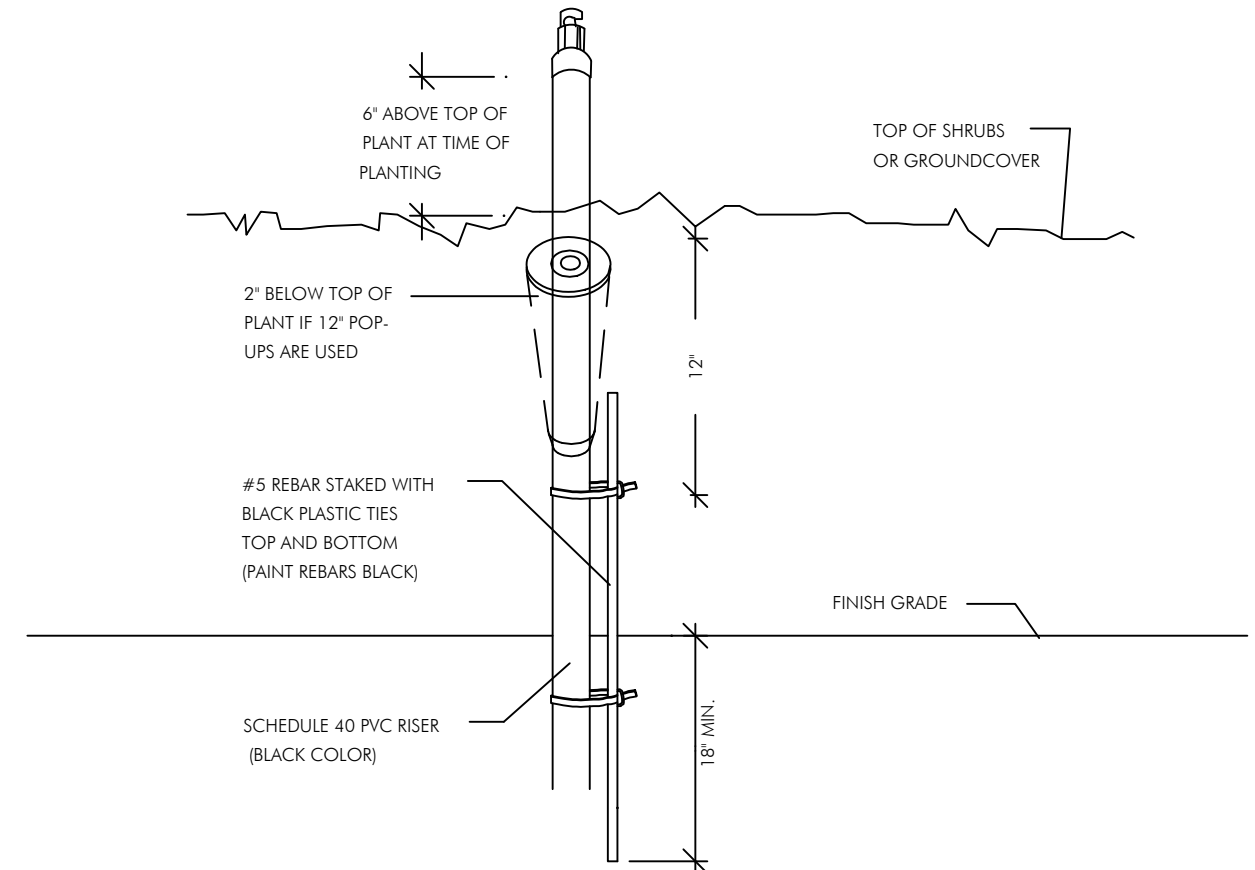

SPRINKLER ON RISER DETAIL FOR SHRUB AREAS

N.T.S.

Irrigation Specs & Details

SCALE: N.T.S.

LA-015



GARDNER + SEMLER
LANDSCAPE ARCHITECTURE
WWW.GSLADDESIGN.COM
17470 NW 78th AVE., SUITE 214
MIAMI, FL 33157
P 305.392.1016 F 305.392.1019
CORP. ID #0000266

CASA LEROY
1339 14TH TERRACE MIAMI BEACH, FLORIDA 33139
MATEU ARCHITECTURE, INC.
8887 SW 131 STREET MIAMI, FLORIDA 33176
TEL: 305.233.3304
FAX: 305.233.3308
FIRST SUBMITTAL 04.29.2024

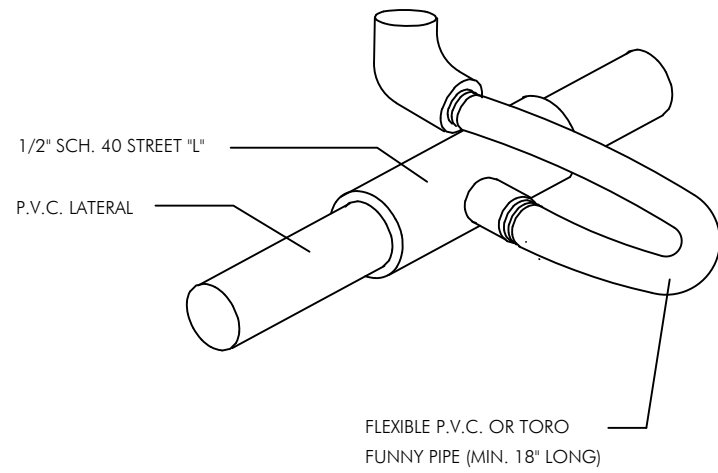

FLEXIBLE SWING JOINT DETAIL

N.T.S.

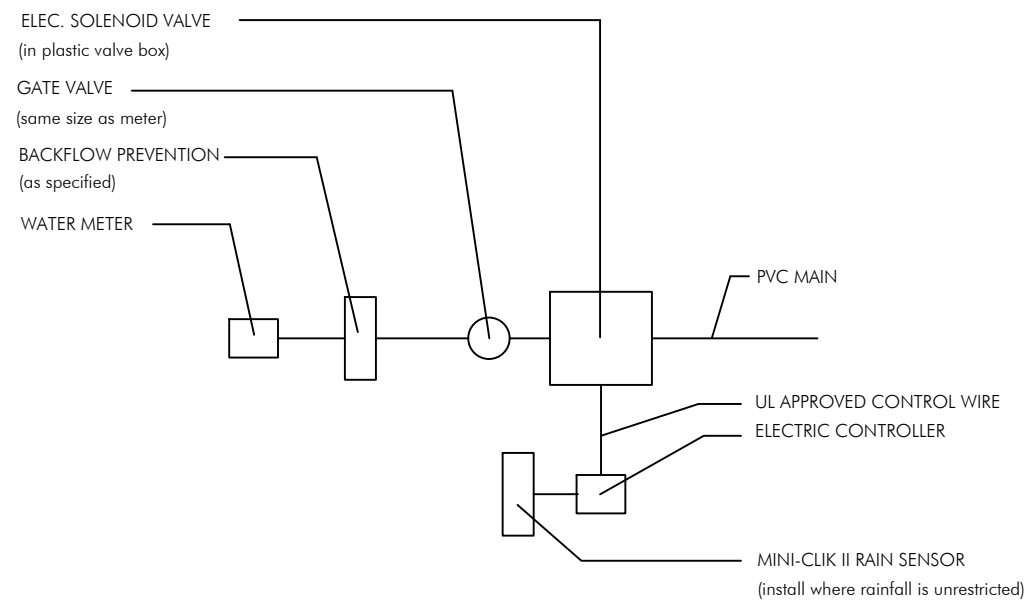

CONNECTION TO METER DETAIL

N.T.S.

NOTE:
ALL WIRE CONNECTIONS SHALL BE APPROVED WATERTIGHT CONNECTIONS.
FINISH ENTIRE ASSEMBLY, EXCEPT FOR EQUIPMENT, WITH FLAT BLACK ACRYLIC ENAMEL PAINT.
PRIME METALLIC SURFACES WITH ZINC CHROMATE PRIOR TO FINISHING.

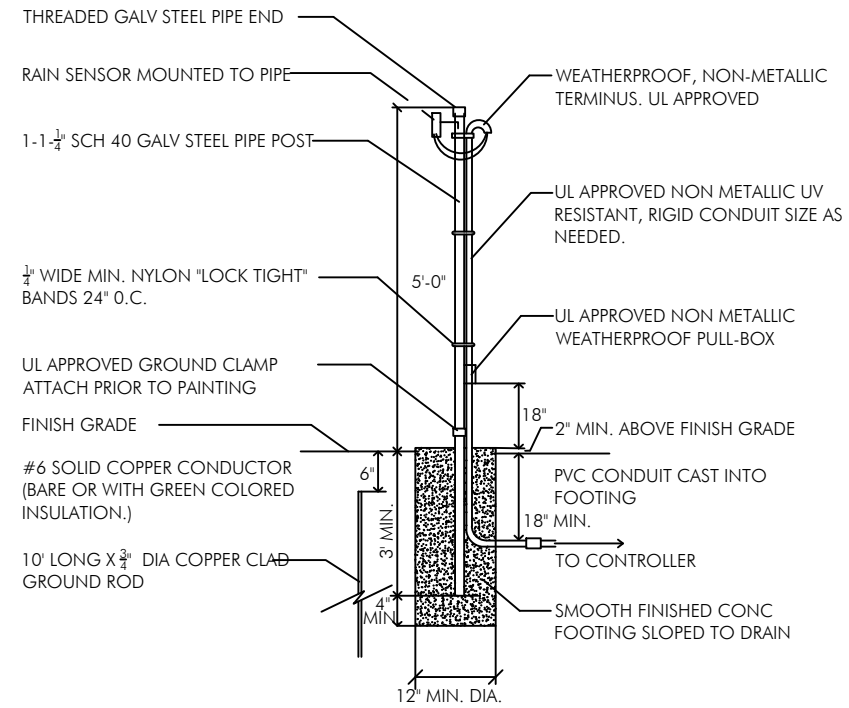

RAIN SENSOR DETAIL

N.T.S.

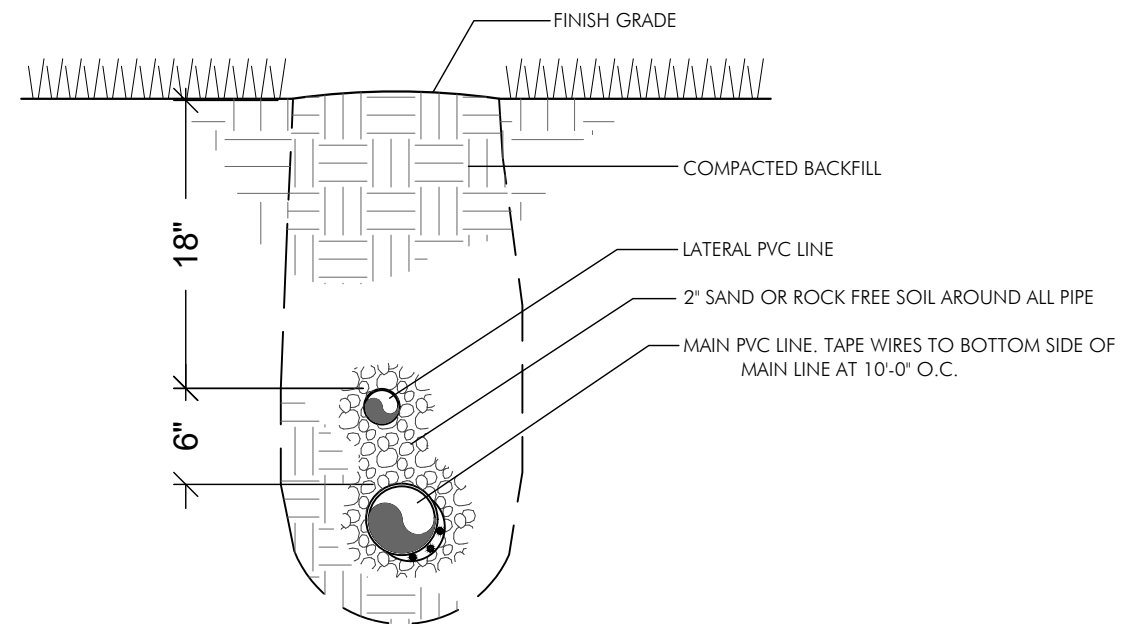

TRENCH DETAIL

N.T.S.

Irrigation Specs & Details

SCALE: N.T.S.

LA-016



CASA LEROY
1339 14TH TERRACE MIAMI BEACH, FLORIDA 33139

MATEU ARCHITECTURE, INC.
8887 SW 131 STREET MIAMI, FLORIDA 33176

TEL: 305.233.3304
FAX: 305.233.3308

FIRST SUBMITTAL 04.29.2024

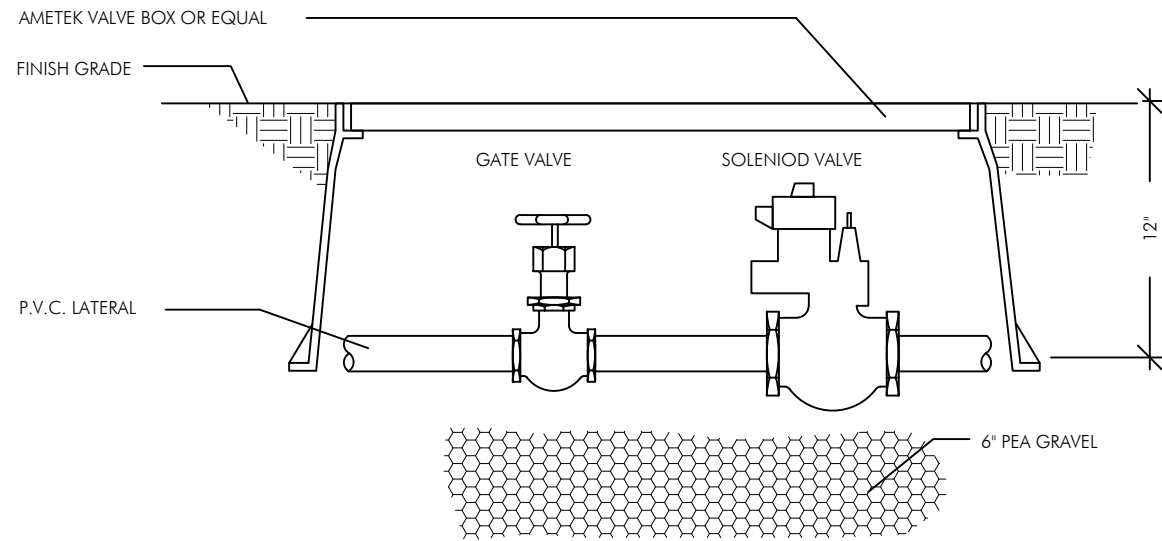

TYPICAL SOLENOID VALVE ASSEMBLY

N.T.S.

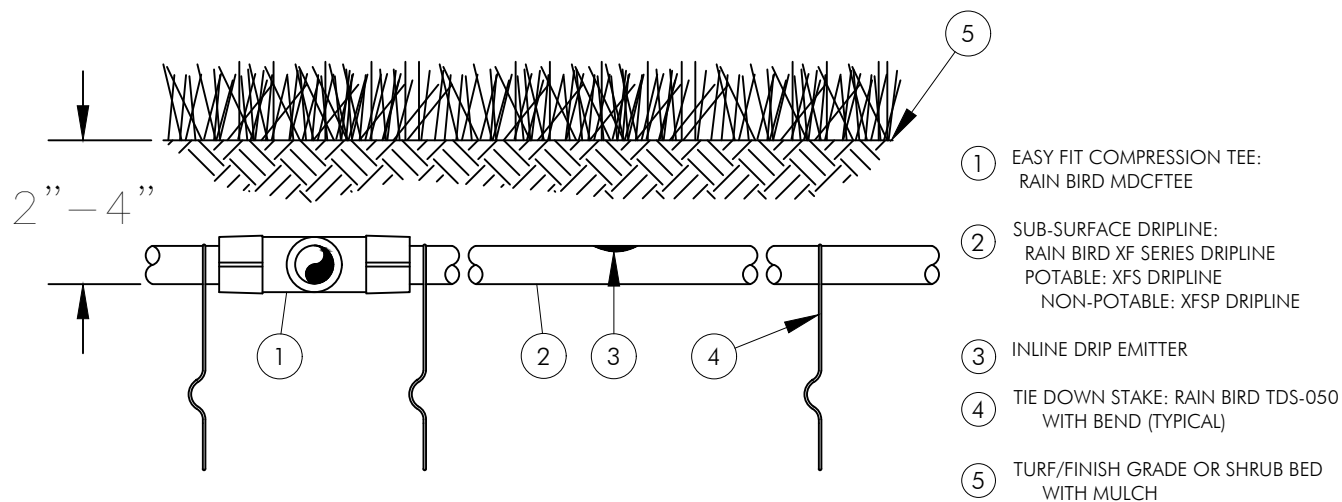

NOTES:

1. PLACE TIE DOWN STAKES EVERY THREE FEET IN SAND, FOUR FEET IN LOAM, AND FIVE FEET IN CLAY.
2. AT FITTINGS WHERE THERE IS A CHANGE OF DIRECTION SUCH AS TEES OR ELBOWS, USE TIE-DOWN STAKES ON EACH LEG OF THE CHANGE OF DIRECTION.
3. INSERTION FLOW AND TRENCHED INSTALLATIONS DO NOT REQUIRE TIE DOWN STAKES.

XFS SUBSURFACE DRIPLINE BURIAL

N.T.S.

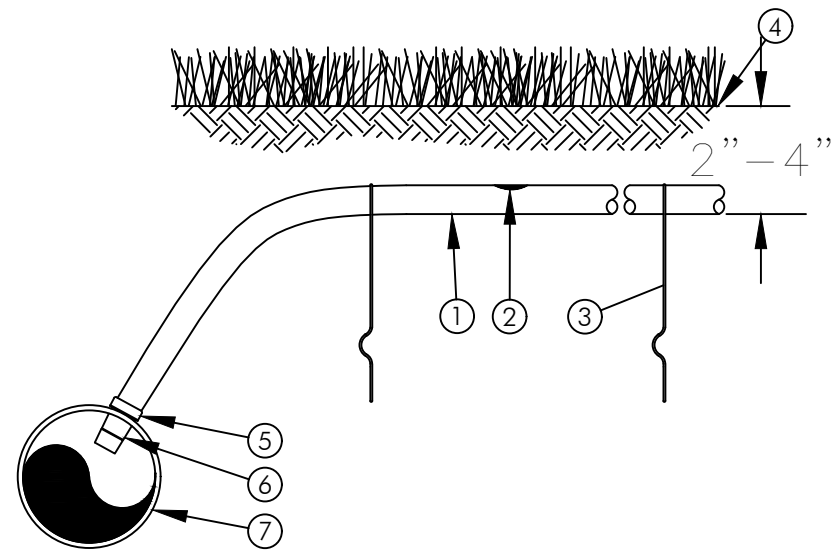

NOTES:

1. PLACE TIE DOWN STAKES EVERY THREE FEET IN SAND, FOUR FEET IN LOAM, AND FIVE FEET IN CLAY.
2. AT FITTINGS WHERE THERE IS A CHANGE OF DIRECTION SUCH AS TEES OR ELBOWS, USE TIE-DOWN STAKES ON EACH LEG OF THE CHANGE OF DIRECTION.
3. INSERTION FLOW AND TRENCHED INSTALLATIONS DO NOT REQUIRE TIE DOWN STAKES.

XFS SUBSURFACE DRIPLINE ADAPTER FOR PVC

N.T.S.

- 1 SUB-SURFACE DRIPLINE:
RAIN BIRD XF SERIES DRIPLINE
POTABLE: XFS DRIPLINE
NON-POTABLE: XFSP DRIPLINE
- 2 INLINE DRIP EMITTER OUTLET
- 3 TIE DOWN STAKE: RAIN BIRD TDS-050
WITH BEND (TYPICAL)
- 4 TURF/FINISH GRADE OR SHRUB BED
WITH MULCH
- 5 RATCHET CLAMP (INCLUDED WITH
ADAPTER)
- 6 INSERT ADAPTER FOR PVC PIPE:
RAIN BIRD XFD-INVPC
- 7 PVC LATERAL PIPE
MINIMUM 1½" IN DIAMETER
DEPTH PER SPECIFICATION

Irrigation Specs & Details

SCALE: N.T.S.

LA-017



GARDNER + SEMLER
LANDSCAPE ARCHITECTURE
WWW.GSLADDESIGN.COM
17470 NW 78th AVE., SUITE 214
MIAMI, FL 33157
P 305.392.1010 F 305.392.1019
CORP. 1 D # 0000266

CASA LEROY

1339 14TH TERRACE MIAMI BEACH, FLORIDA 33139

MATEU ARCHITECTURE, INC.

8887 SW 131 STREET MIAMI, FLORIDA 33176

TEL: 305.233.3304 FAX: 305.233.3306

FIRST SUBMITTAL

04.29.2024

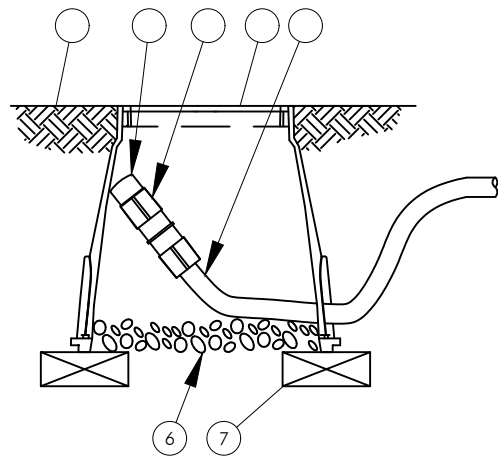

- ① FINISH GRADE
- ② FLUSH CAP FOR EASY FIT COMPRESSION FITTINGS:
POTABLE: RAIN BIRD MDCFCAP
NON-POTABLE: RAIN BIRD MDCFPCAP
- ③ EASY FIT COUPLING:
RAIN BIRD MDCFCOUP
- ④ SUBTERRANEAN EMITTER BOX:
RAIN BIRD SEB 7XB
- ⑤ SUB-SURFACE DRIPLINE:
RAIN BIRD XF SERIES DRIPLINE
POTABLE: XFS DRIPLINE
NON-POTABLE: XFS DRIPLINE
- ⑥ 3-INCH MINIMUM DEPTH OF
3/4-INCH WASHED GRAVEL
- ⑦ BRICK (1 OF 2)

NOTE:
1. ALLOW A MINIMUM OF 6-INCHES OF DRIPLINE TUBING IN VALVE BOX IN ORDER TO DIRECT FLUSHED WATER OUTSIDE VALVE BOX.

XFS DRIPLINE FLUSHPOINT WITH COMPRESSION FITTINGS

N.T.S.

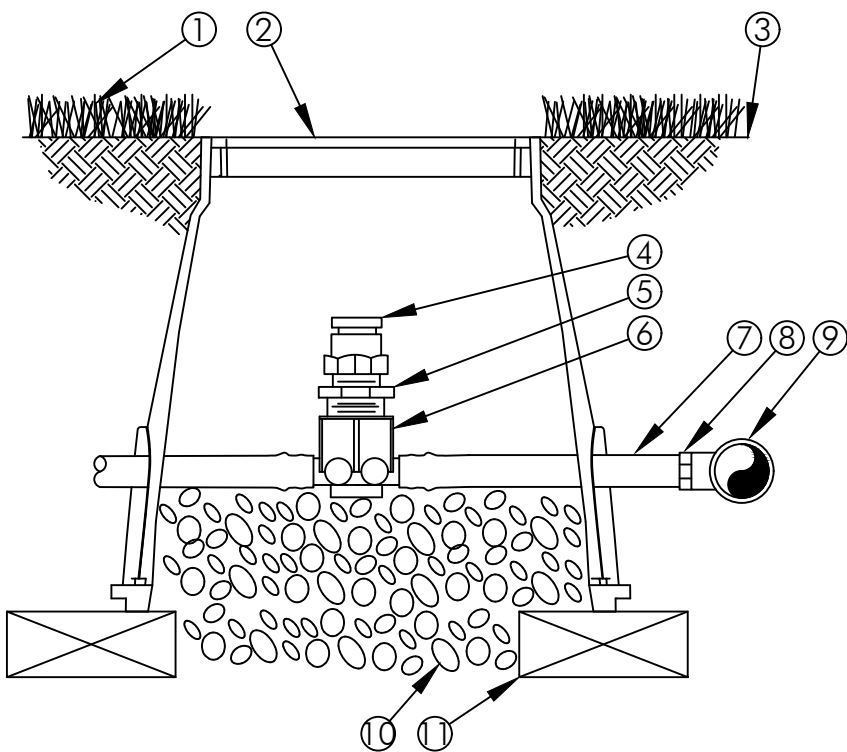

- ① TURF GRASS
- ② SUBTERRANEAN EMITTER BOX:
RAIN BIRD SEB 7XB
- ③ FINISH GRADE
- ④ 1/2" AIR RELIEF VALVE:
RAIN BIRD ARV050
TO BE INSTALLED AT HIGH POINTS IN DRIP ZONE
- ⑤ 1/2" X 3/4" PVC REDUCER BUSHING
- ⑥ BARB X FEMALE THREAD CONNECTOR:
RAIN BIRD XFD-TFA FITTING
- ⑦ 1/2" BLANK DRIPLINE TUBING:
RAIN BIRD XF SERIES
- ⑧ BARB X MALE THREAD CONNECTOR:
RAIN BIRD XFF-MA FITTING
- ⑨ PVC TEE CONNECTED TO PVC HEADER PIPE
- ⑩ 3" MINIMUM DEPTH OF
3/4" WASHED GRAVEL
- ⑪ BRICK (1 OF 2)

XFS AIR/VACUUM RELIEF

N.T.S.

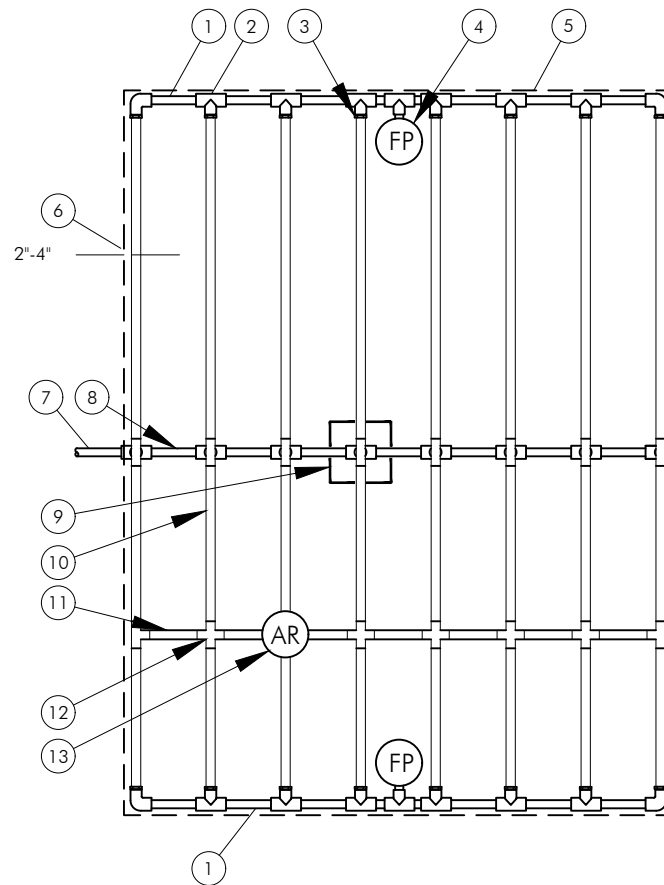

- ① PVC EXHAUST HEADER
- ② PVC SCH 40 TEE OR EL (TYPICAL)
- ③ BARB X MALE FITTING:
RAIN BIRD XFF-MA FITTING (TYPICAL)
- ④ FLUSH POINT (TYPICAL)
SEE RAIN BIRD DETAIL "XFS FLUSH POINT" OR "XFS FLUSH POINT WITH BALL VALVE"
- ⑤ PERIMETER OF AREA
- ⑥ PERIMETER DRIPLINE PIPE TO BE INSTALLED 2"-4" FROM PERIMETER OF AREA
- ⑦ PVC SUPPLY PIPE FROM RAIN BIRD CONTROL ZONE KIT (SIZED TO MEET LATERAL FLOW DEMAND)
- ⑧ PVC SUPPLY MANIFOLD
- ⑨ CONNECTION FROM SUPPLY MANIFOLD TO DRIPLINE (TYPICAL)- SEE INSET A

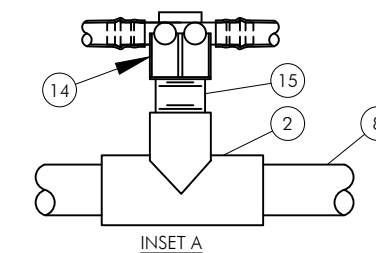

- ⑩ SUB-SURFACE DRIPLINE:
RAIN BIRD XF SERIES DRIPLINE (TYPICAL)
POTABLE: XFS DRIPLINE
NON-POTABLE: XFS DRIPLINE
- ⑪ RAIN BIRD XF SERIES BLANK TUBING
- ⑫ BARB X BARB INSERT TEE OR CROSS:
RAIN BIRD XFF-TEE OR
RAIN BIRD XFD-CROSS (TYPICAL)
- ⑬ 1/2" AIR RELIEF VALVE: RAIN BIRD MODEL:
ARV050
SEE RAIN BIRD XFS DETAILS FOR AIR RELIEF INSTALLATION
- ⑭ BARB X FEMALE FITTING:
RAIN BIRD XFD-TFA-075 FITTING
- ⑮ 3/4" PVC NIPPLE, LENGTH AS NECESSARY

- NOTES:
1. DISTANCE BETWEEN LATERAL ROWS AND EMITTER SPACING TO BE BASED ON SOIL TYPE, PLANT MATERIALS AND CHANGES IN ELEVATION. SEE RAIN BIRD XF-SDI DRIPLINE INSTALLATION GUIDE FOR SUGGESTED SPACINGS.
 2. LENGTH OF LONGEST DRIPLINE LATERAL SHOULD NOT EXCEED THE MAXIMUM LENGTH SHOWN IN THE ACCOMPANYING TABLE.
 3. AIR RELIEF VALVE TO BE INSTALLED AT HIGH POINT OF AREA.
 4. WHEN USING 17MM INSERT FITTINGS WITH DESIGN PRESSURE OVER 50PSI, IT IS RECOMMENDED THAT STAINLESS STEEL CLAMPS BE INSTALLED ON EACH FITTING.

XFS Dripline Maximum Lateral Lengths (Feet)

Inlet Pressure psi	12" Spacing		18" Spacing		24" Spacing	
	Nominal Flow (gph)	Nominal Flow (gph)	Nominal Flow (gph)	Nominal Flow (gph)	Nominal Flow (gph)	Nominal Flow (gph)
15	0.6	0.9	0.6	0.9	0.6	0.9
20	273	155	314	250	424	322
30	318	169	353	294	508	368
40	360	230	413	350	586	414
50	395	255	465	402	652	474
60	417	285	528	420	720	488
	460	290	596	455	780	514

XFS SUBSURFACE DRIPLINE CENTERFEED LAYOUT

N.T.S.

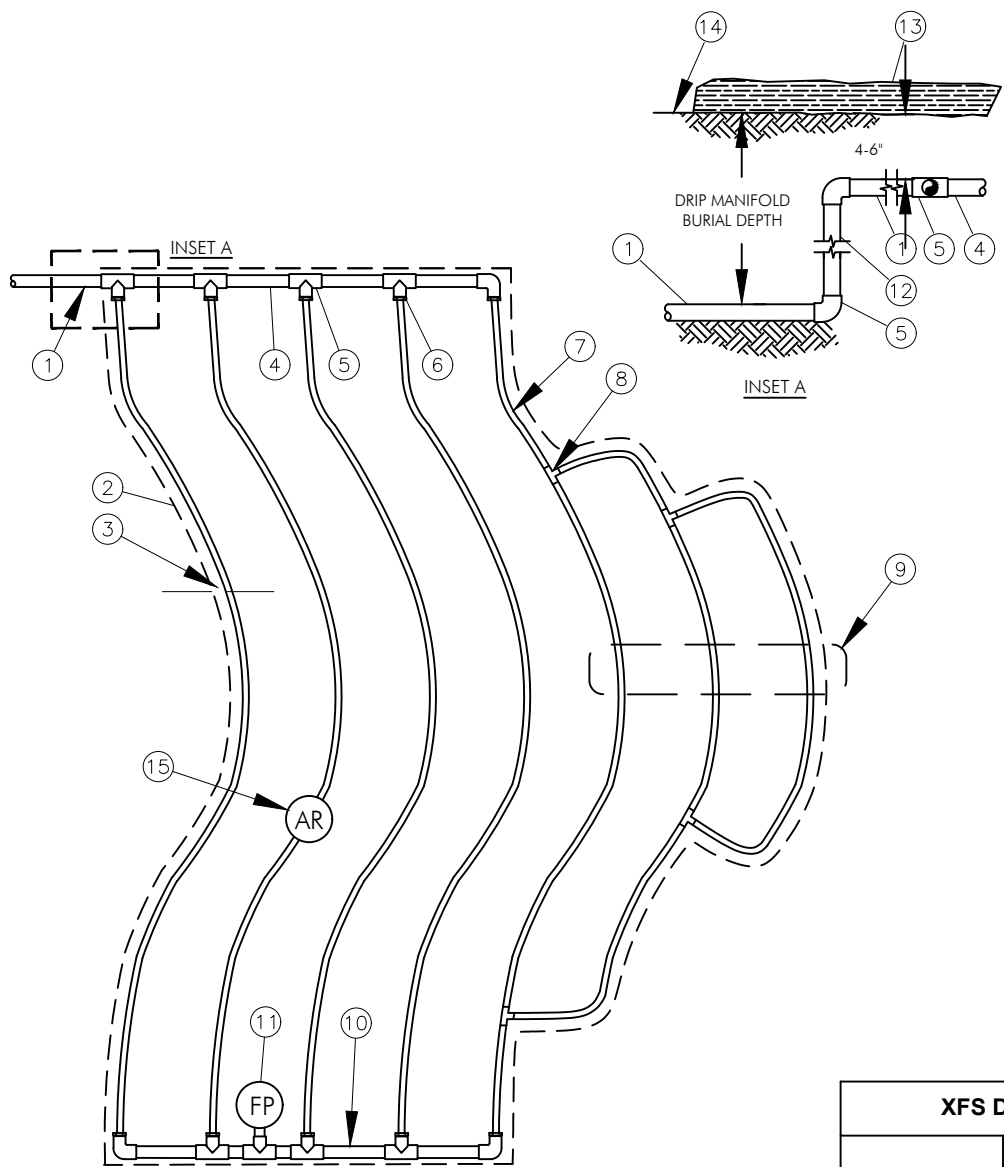

- NOTES:
- DISTANCE BETWEEN LATERAL ROWS AND EMITTER SPACING TO BE BASED ON SOIL TYPE, PLANT MATERIALS AND CHANGES IN ELEVATION. SEE INSTALLATION SPECIFICATIONS ON RAIN BIRD WEB SITE (WWW.RAINBIRD.COM) FOR SUGGESTED SPACING.
 - LENGTH OF LONGEST DRIPLINE LATERAL SHOULD NOT EXCEED THE MAXIMUM SPACING SHOWN IN THE ACCOMPANYING TABLE.
 - INSTALL AIR RELIEF VALVE AT HIGH POINTS IN DRIP LATERAL.
 - WHEN USING 17MM INSERT FITTINGS WITH DESIGN PRESSURE OVER 50PSI, IT IS RECOMMENDED THAT STAINLESS STEEL CLAMPS BE INSTALLED ON EACH FITTING.

Inlet Pressure psi	12" Spacing		18" Spacing		24" Spacing	
	Nominal Flow (gph)		Nominal Flow (gph)		Nominal Flow (gph)	
	0.6	0.9	0.6	0.9	0.6	0.9
15	273	155	314	250	424	322
20	318	169	353	294	508	368
30	360	230	413	350	586	414
40	395	255	465	402	652	474
50	417	285	528	420	720	488
60	460	290	596	455	780	514

- PVC SUPPLY PIPE FROM RAIN BIRD CONTROL ZONE KIT (SIZED TO MEET LATERAL FLOW DEMAND)
- PERIMETER OF AREA
- PERIMETER DRIPLINE PIPE TO BE INSTALLED 2"-4" FROM PERIMETER OF AREA
- PVC SUPPLY MANIFOLD
- PVC SCH 40 TEE OR EL (TYPICAL)
- BARB X MALE FITTING: RAIN BIRD XFF-MA FITTING (TYPICAL)
- SUB-SURFACE DRIPLINE: RAIN BIRD XF SERIES DRIPLINE (TYPICAL)
POTABLE: XFS DRIPLINE
NON-POTABLE: XFSP DRIPLINE
- BARB X BARB INSERT TEE: RAIN BIRD XFF-TEE (TYPICAL)
- TOTAL LENGTH OF SELECTED DRIPLINE SHOULD NOT EXCEED LENGTH SHOWN IN TABLE
- PVC FLUSH HEADER
- FLUSH POINT: SEE RAIN BIRD XFS DETAILS FOR FLUSH POINT INSTALLATION
- PVC RISER PIPE
- TURF OR MULCH
- FINISH GRADE
- 1/2" AIR RELIEF VALVE: RAIN BIRD MODEL: ARV050 SEE RAIN BIRD XFS DETAILS FOR AIR RELIEF INSTALLATION

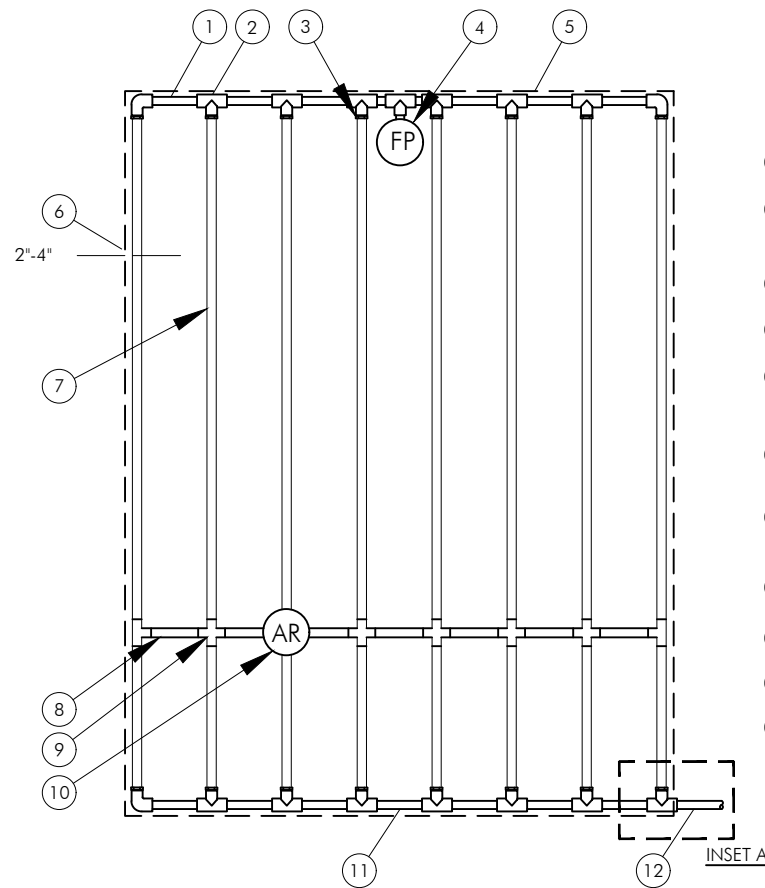

- NOTES:
- DISTANCE BETWEEN LATERAL ROWS AND EMITTER SPACING TO BE BASED ON SOIL TYPE, PLANT MATERIALS AND CHANGES IN ELEVATION. SEE RAIN BIRD XFS DRIPLINE INSTALLATION GUIDE FOR SUGGESTED SPACINGS.
 - LENGTH OF LONGEST DRIPLINE LATERAL SHOULD NOT EXCEED THE MAXIMUM LENGTH SHOWN IN THE ACCOMPANYING TABLE.
 - AIR RELIEF VALVE TO BE INSTALLED AT HIGH POINT OF AREA.
 - WHEN USING 17MM INSERT FITTINGS WITH DESIGN PRESSURE OVER 50PSI, IT IS RECOMMENDED THAT STAINLESS STEEL CLAMPS BE INSTALLED ON EACH FITTING.

- PVC EXHAUST HEADER
- PVC SCH 40 TEE OR EL (TYPICAL)
- BARB X MALE FITTING: RAIN BIRD XFF-MA FITTING (TYPICAL)
- FLUSH POINT (TYPICAL) SEE RAIN BIRD DETAIL "XFS FLUSH POINT" OR "XFS FLUSH POINT WITH BALL VALVE"
- PERIMETER OF AREA
- PERIMETER DRIPLINE PIPE TO BE INSTALLED 2"-4" FROM PERIMETER OF AREA
- SUB-SURFACE DRIPLINE: RAIN BIRD XF SERIES DRIPLINE (TYPICAL)
POTABLE: XFS DRIPLINE
NON-POTABLE: XFSP DRIPLINE
- RAIN BIRD XF SERIES BLANK TUBING
- BARB X BARB INSERT TEE OR CROSS: RAIN BIRD XFF-TEE OR RAIN BIRD XFD-CROSS (TYPICAL)
- 1/2" AIR RELIEF VALVE: RAIN BIRD MODEL: ARV050 SEE RAIN BIRD XFS DETAILS FOR AIR RELIEF INSTALLATION
- PVC SUPPLY HEADER
- PVC DRIP MANIFOLD FROM RAIN BIRD CONTROL ZONE VALVE KIT (SIZED TO MEET LATERAL FLOW DEMAND)
- PVC SCH 40 RISER PIPE

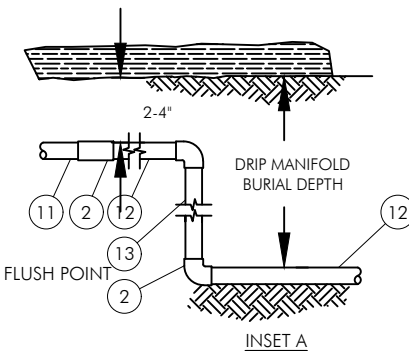

Inlet Pressure psi	12" Spacing		18" Spacing		24" Spacing	
	Nominal Flow (gph)		Nominal Flow (gph)		Nominal Flow (gph)	
	0.6	0.9	0.6	0.9	0.6	0.9
15	273	155	314	250	424	322
20	318	169	353	294	508	368
30	360	230	413	350	586	414
40	395	255	465	402	652	474
50	417	285	528	420	720	488
60	460	290	596	455	780	514

XFS SUBSURFACE DRIPLINE END FEED LAYOUT

N.T.S.

XFS SUBSURFACE DRIPLINE ODD CURVES LAYOUT

N.T.S.

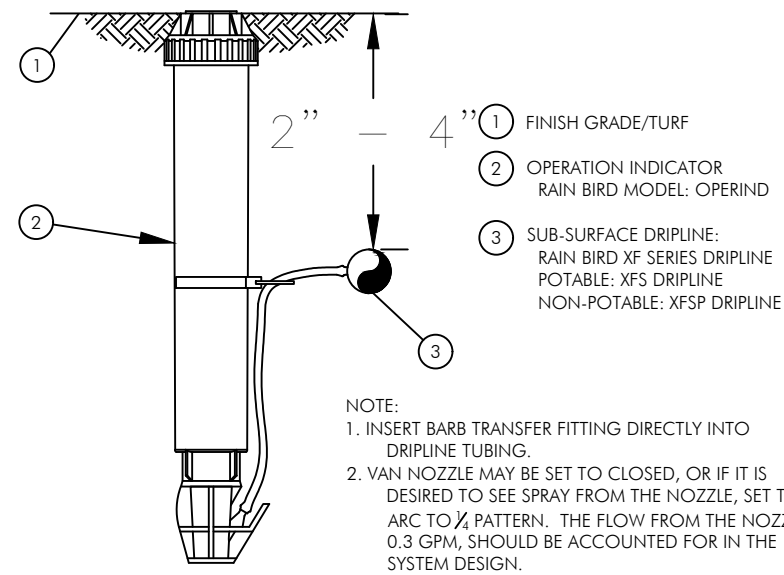

- ① FINISH GRADE/TURF
- ② OPERATION INDICATOR
RAIN BIRD MODEL: OPERIND
- ③ SUB-SURFACE DRIPLINE:
RAIN BIRD XF SERIES DRIPLINE
POTABLE: XFS DRIPLINE
NON-POTABLE: XFSP DRIPLINE

NOTE:
 1. INSERT BARB TRANSFER FITTING DIRECTLY INTO DRIPLINE TUBING.
 2. VAN NOZZLE MAY BE SET TO CLOSED, OR IF IT IS DESIRED TO SEE SPRAY FROM THE NOZZLE, SET THE ARC TO 1/4 PATTERN. THE FLOW FROM THE NOZZLE, 0.3 GPM, SHOULD BE ACCOUNTED FOR IN THE SYSTEM DESIGN.

XFS SUBSURFACE DRIPLINE OPERATION INDICATOR

N.T.S.

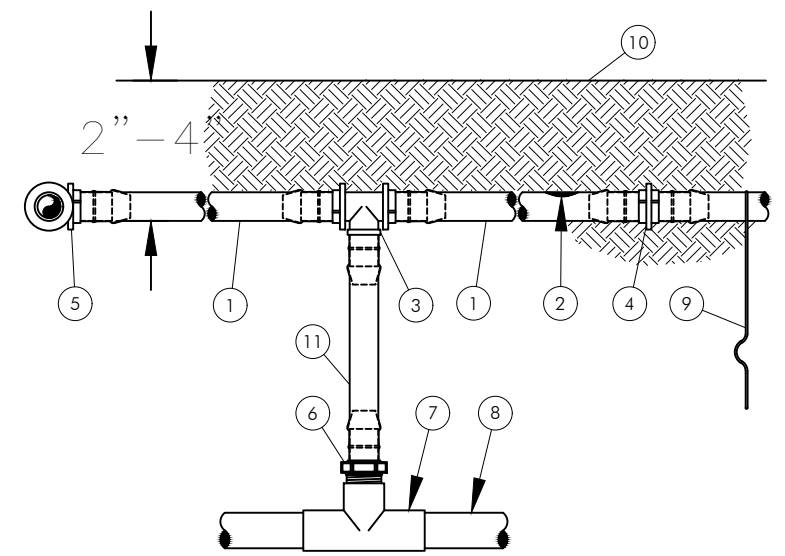

- ① ON-SURFACE DRIPLINE:
RAIN BIRD XF SERIES DRIPLINE
POTABLE: XFS DRIPLINE
NON-POTABLE: XFSP DRIPLINE
- ② INLINE DRIP EMITTER OUTLET, SEE PLANS FOR DRIPLINE OUTLET SPACING.
- ③ BARB TEE 17x17x17mm
RAIN BIRD XFF-TEE
- ④ BARB COUPLING 17x17mm
RAIN BIRD XFF-COUP
- ⑤ BARB ELBOW 17x17mm
RAIN BIRD XFF-ELBOW
- ⑥ BARB MALE ADAPTER
17mm X 1/2" MPT
RAIN BIRD XFF-MA-050
17mm X 3/4" MPT
RAIN BIRD XFF-MA-075
- ⑦ PVC TEE SxSxT
- ⑧ PVC LATERAL SUPPLY HEADER
- ⑨ TIE DOWN STAKE:
RAIN BIRD TDS-050 WITH BEND (TYPICAL)
- ⑩ FINISH GRADE
- ⑪ RAIN BIRD XF SERIES BLANK TUBING
LENGTH AS REQUIRED

NOTES:
 1. PLACE TIE DOWN STAKES EVERY THREE FEET IN SAND, FOUR FEET IN LOAM, AND FIVE FEET IN CLAY.
 2. AT FITTINGS WHERE THERE IS A CHANGE OF DIRECTION SUCH AS TEES OR ELBOWS, USE TIE-DOWN STAKES ON EACH LEG OF THE CHANGE OF DIRECTION.
 3. SAVE YOUR HANDS. USE THE RAIN BIRD FITTINGS-TOOL XF INSERTION TOOL FOR FITTING ASSEMBLY.

XFS SUBSURFACE DRIPLINE RISER ASSEMBLY

N.T.S.