

"SHELLSTONE" PAVERS
BY TREMRON
SANDSTONE COLOR, HERRINGBONE PATTERN

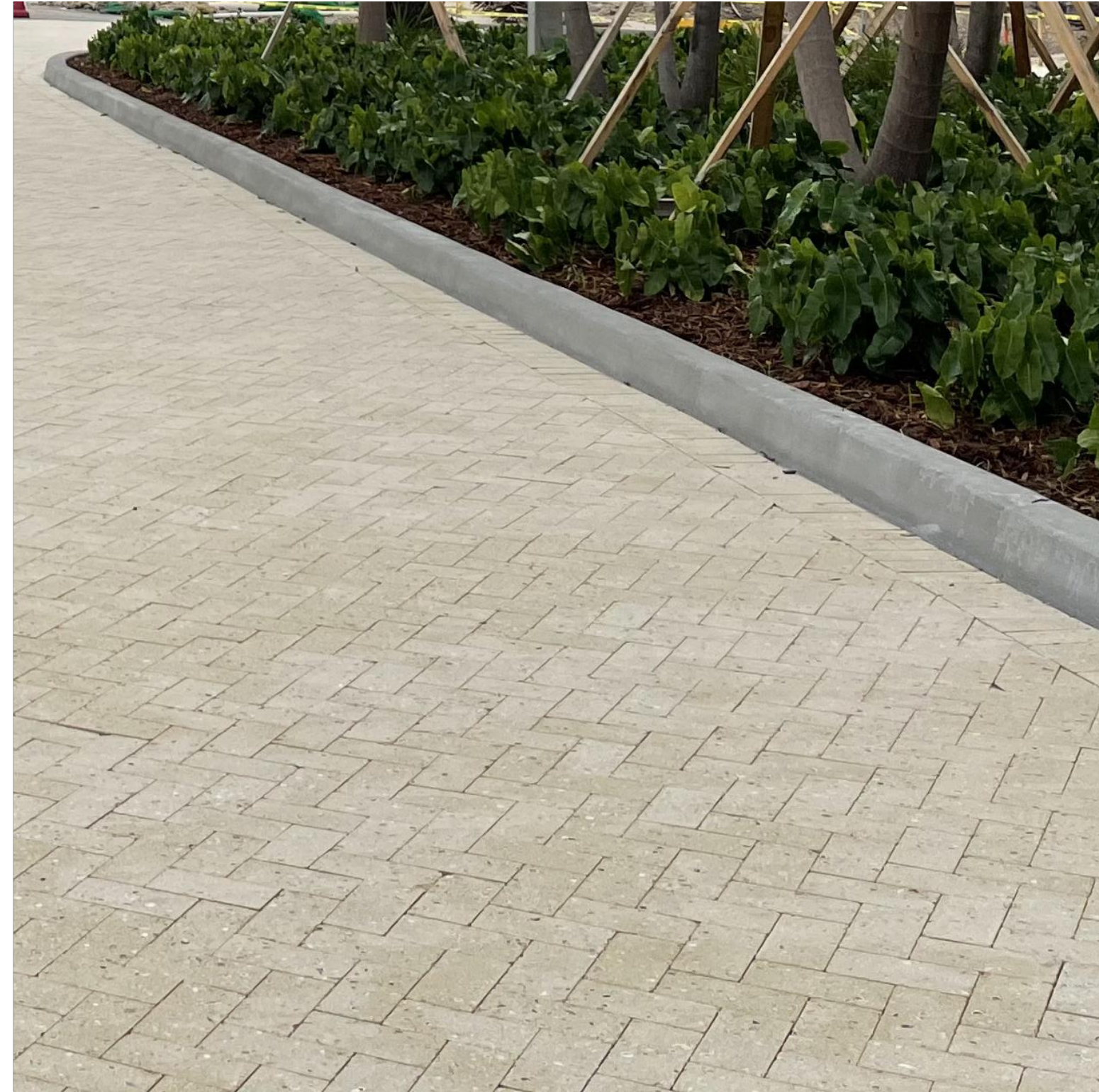

"PURE" PERVIOUS COBBLE PAVERS
BY TECHO-BLOC
CHAMPLAIN GREY COLOR, RUNNING BOND PATTERN



PORPHYRY COBBLESTONE PAVERS
BY ARQUIGREEN
MIXED RED COLOR, RUNNING BOND PATTERN



STONE PAVERS
BY A&P CORAL CLASSICS
"CORAL REEF WHITE, BRUSHED AND FILLED, RUNNING BOND PATTERN



CAST-IN-PLACE CONCRETE
STANDARD GREY COLOR, SANDBLAST FINISH



MIAMI BEACH PINK
CAST-IN-PLACE CONCRETE
MIAMI BEACH PINK COLOR, LIGHT BROOM FINISH



revuelta
architecture
international

Miami
Santiago, Chile

revuelta-architecture.com

2950 SW 27TH AVE
SUITE 110
MIAMI, FL 33135
T: 305.593.9000
F: 305.593.9040

ALVARO | ROBERTO | RODRIGO
Project

1940 Bay Drive
1940 BAY DRIVE
Miami Beach, Florida 33141

Revisions

Owner Information

#Client Company

#Client Address1

#Client Address2

#Client City, #Client State

#Client Postcode

#Client Phone Number

Consultant

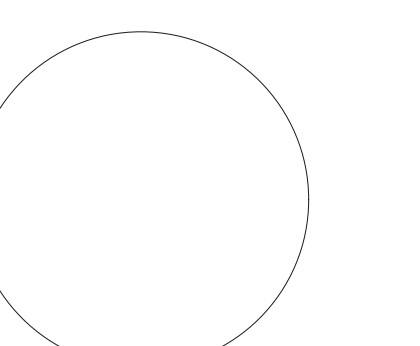
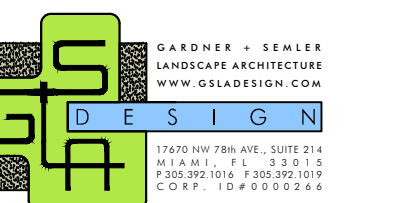

Taylor Kiehl Semler
PLA-FL6667205

DRB SUBMITTAL

Date

08/04/2023

Scale

AS SHOWN

Project No.

2133

Sheet Name

HARDSCAPE

MATERIAL PHOTOS

Sheet No.

LA-202

NOT FOR CONSTRUCTION

These Drawings and Specifications are the Copyright Property of Revuelta Architecture International, P.A. and may not be reproduced, stored in a retrieval system, or transmitted in any form or by any means, electronic, mechanical, photocopying, recording, or by any information storage and retrieval system, without the prior written permission of Revuelta Architecture International, P.A. All rights reserved. 08/04/2023

LANDSCAPE SPECIFICATIONS PART 1 - GENERAL

1.1 SCOPE
A. Contractor shall provide all labor, materials, equipment, supervision, and related work necessary to complete the landscape work in accordance with the intent of the landscape plans, schedules and these specifications.

1.2 CONTRACTOR QUALIFICATIONS
A. Landscape installation work to be performed by a Contractor Certified by the Florida Nurserymen, Growers and Landscape Association (FNLGA) as a Certified Landscape Contractor.

1.3 INVESTIGATION OF UTILITIES
A. Prior to beginning work, the Contractor shall be responsible to locate existing underground utilities.

1.4 SUBSTITUTIONS
A. Only materials specified will be accepted, unless approved in writing by the Landscape Architect in advance.

1.5 PLANT SIZES
A. All plant sizes shall equal or exceed the minimum sizes as specified in the plant list.

1.6 PLANT QUALITY
A. All plant material shall be equal to or better than Florida No. 1 as classified by "Grades and Standards for Nursery Plants" by the Division of Plant Industry, Florida Department of Agriculture.

1.7 PLANT QUANTITY
A. The plant quantities shown on the plant list are to be used only as an aid to bidders.

1.8 UNIT PRICES
A. The successful bidder shall furnish to the Owner and the Landscape Architect, a unit price breakdown for all materials.

1.9 SUBMITTALS
A. Fertilizer: The Contractor shall submit to the Owner and Landscape Architect documentation that all the fertilizer used for the project is of the analysis specified and placed on the area specified in section 2.2 FERTILIZING.

1.10 CLEAN-UP & MAINTENANCE OF TRAFFIC
A. Follow procedures in FDOT Index 600 for maintenance of traffic during construction.

1.11 MAINTENANCE PRIOR TO ACCEPTANCE
A. The Contractor is responsible to maintain the plantings until they are accepted under the provisions of 1.12 "ACCEPTANCE OF INSTALLATION".

1.12 ACCEPTANCE OF INSTALLATION
A. Inspection: Inspection of the work to determine completion of contract work, exclusive of the possible replacement of plants and turf, will be made by the Landscape Architect at the conclusion of the maintenance period.

1.13 GUARANTEE
A. Guarantee all plants for a period of one year (CCD). Guarantee shall commence from the date of written acceptance.

1.14 REPLACEMENT
A. Replacement shall be made during the guarantee period as directed by the Landscape Architect within ten (10) days from time of notification.

2.1 PLANTING SOIL
A. Planting soil for trees, shrubs and ground covers shall be of the composition noted on the plans, measured by volume.

2.2 FERTILIZER
A. Fertilizer for trees, palms, shrubs, and groundcovers shall be as follows: LESCO Palm Special 13-3-13 or equal.

2.3 WATER
A. The Contractor shall provide potable water on site, available from the start of planting.

2.4 MULCH
A. Mulch shall be shredded Melaleuca mulch (Florimulch) as manufactured by Forestry Resources, Inc., or equal.

2.5 ROOT BARRIER MATERIAL
A. Root barrier material shall be 24" deep polypropylene panels by Deeproot or approved equal.

B. Install per details in the plans.

PART 3 - INSTALLATION PROCEDURES

3.1 LAYOUT
A. Verify location of all underground utilities and obstructions prior to excavation.

3.2 HERBICIDE TREATMENT
A. In all areas infested with weed and/or grass growth, a systemic herbicide, such as Roundup, shall be applied per manufacturer's rates.

3.3 PLANT PIT EXCAVATION AND BACKFILLING
A. Trees: See the Planting and Bracing Details and notes.

3.4 WATERING
A. The Contractor is responsible to provide the water for all new plants and transplants and means of distribution (i.e. hand watering or water truck) during the maintenance period.

3.5 FERTILIZING
A. Add fertilizer on top of the surface of shrub beds and tree and palms root balls two (2) months after installation.

3.6 MULCHING
A. Spread mulch two (2) inches thick uniformly over the entire surface of shrub and groundcover beds.

3.7 GUYING AND BRACING
A. See the details bound herewith or made part of the plans.

3.8 SODDING
A. Provide a blanket of lawn sand as described in the notes in these plans.

3.9 GUARANTEE
A. Guarantee all plants for a period of one year (CCD). Guarantee shall commence from the date of written acceptance.

3.10 REPLACEMENT
A. Replacement shall be made during the guarantee period as directed by the Landscape Architect within ten (10) days from time of notification.

3.11 PLANTING SOIL
A. Planting soil for trees, shrubs and ground covers shall be of the composition noted on the plans, measured by volume.

3.12 FERTILIZER
A. Fertilizer for trees, palms, shrubs, and groundcovers shall be as follows: LESCO Palm Special 13-3-13 or equal.

3.13 WATER
A. The Contractor shall provide potable water on site, available from the start of planting.

3.14 MULCH
A. Mulch shall be shredded Melaleuca mulch (Florimulch) as manufactured by Forestry Resources, Inc., or equal.

3.15 ROOT BARRIER MATERIAL
A. Root barrier material shall be 24" deep polypropylene panels by Deeproot or approved equal.

B. Install per details in the plans.

ALUMINUM EDGING DETAIL

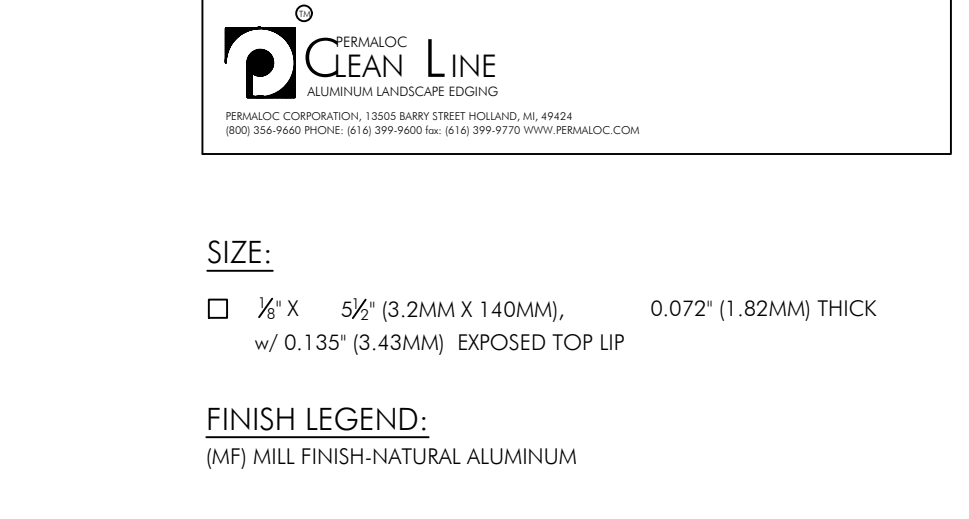

PERMALOC CLEANLINE ALUMINUM EDGING
SIZE: 1/2" X 1/2" (3.2MM X 140MM), 0.072" (1.82MM) THICK
FINISH LEGEND: (M) MILL FINISH-NATURAL ALUMINUM

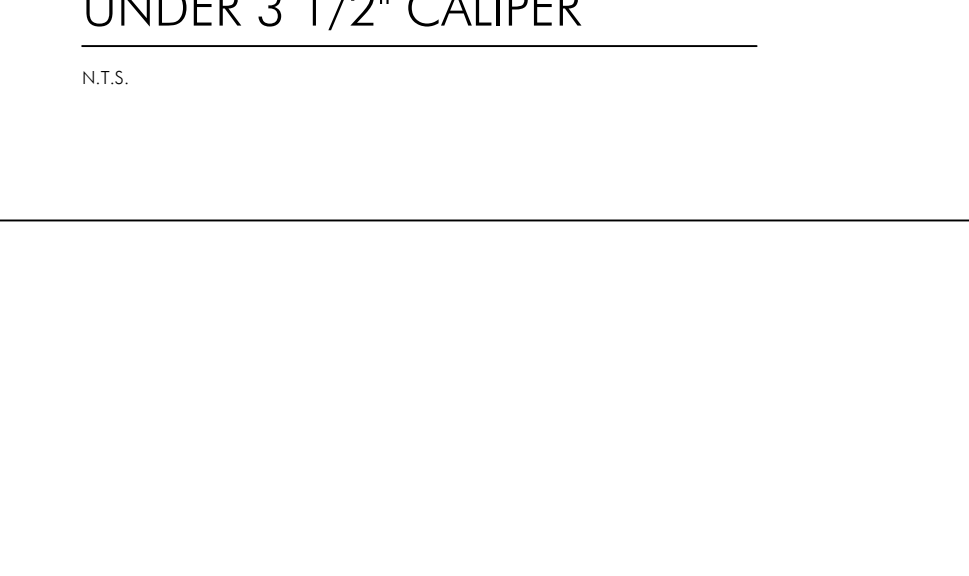
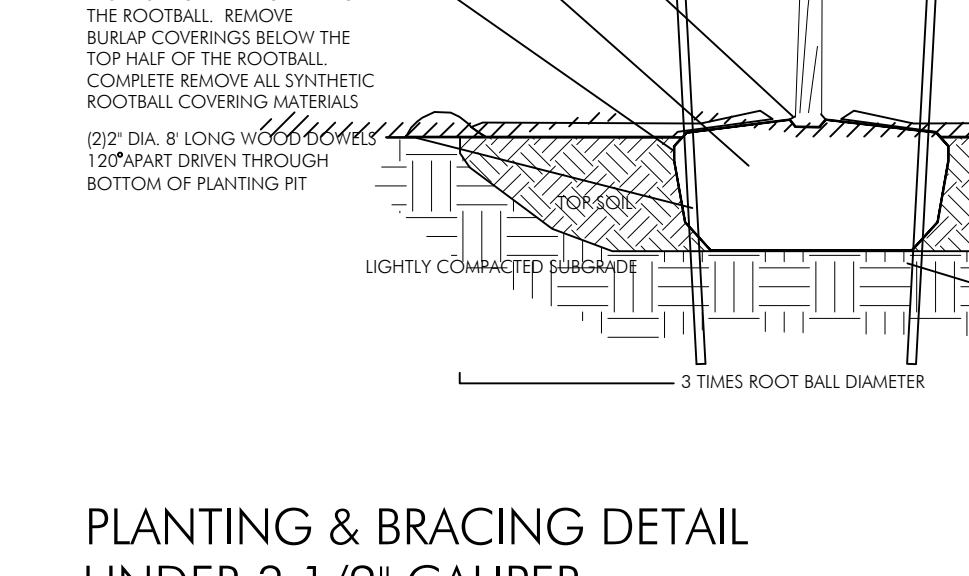
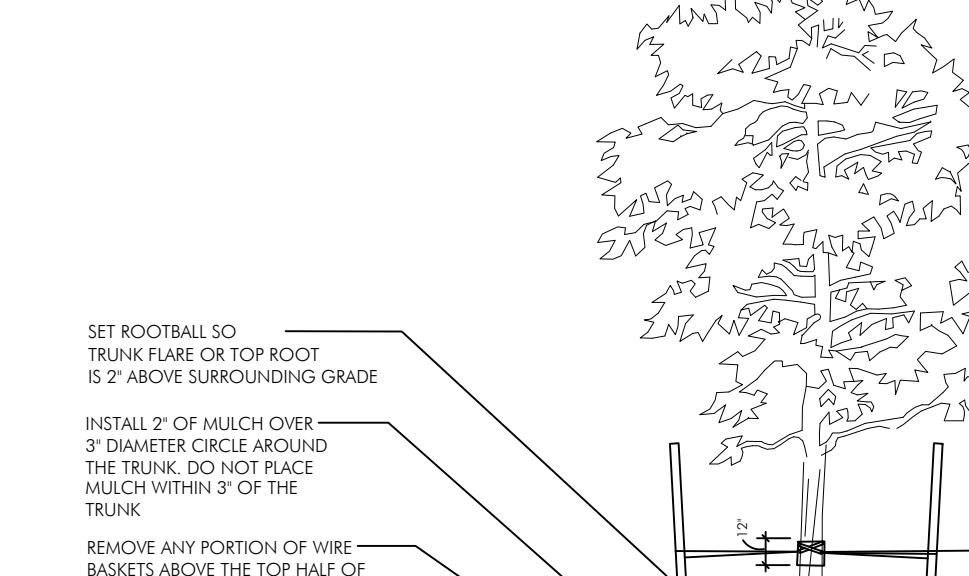
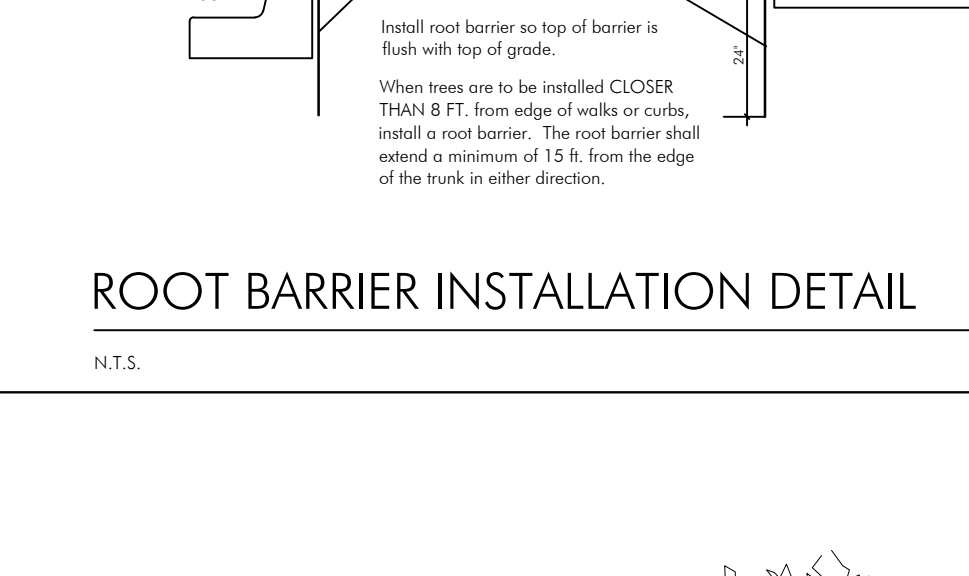
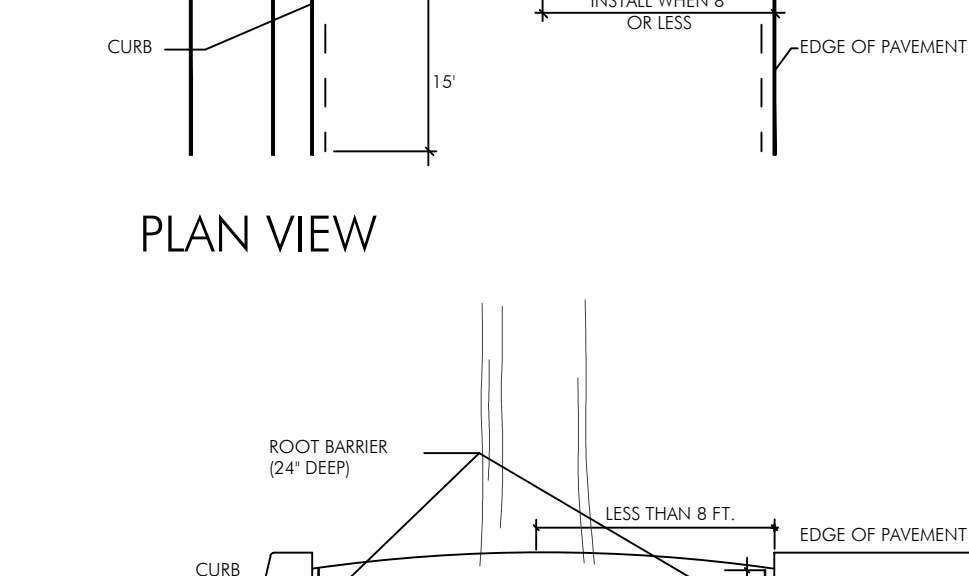
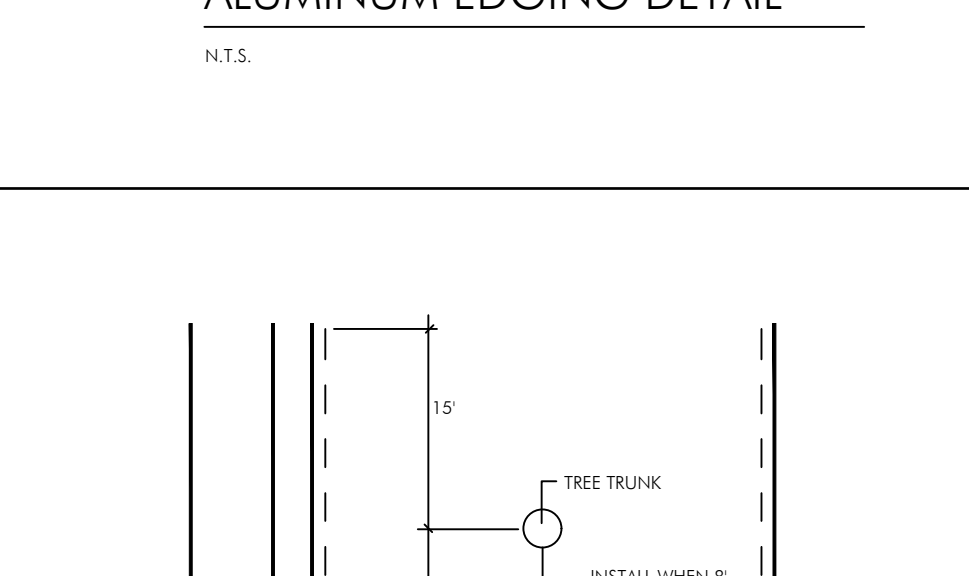

SHRUB SPACING DIAGRAM

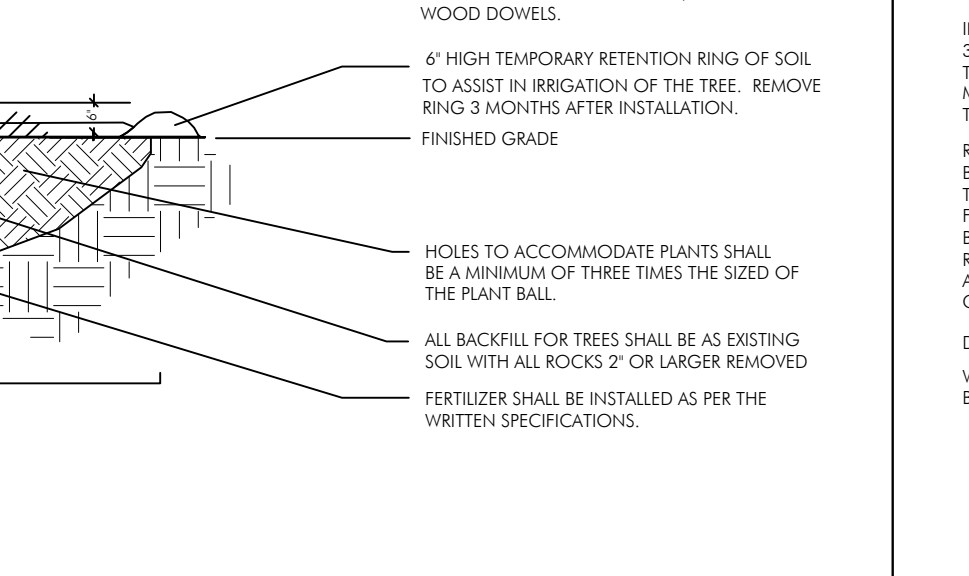
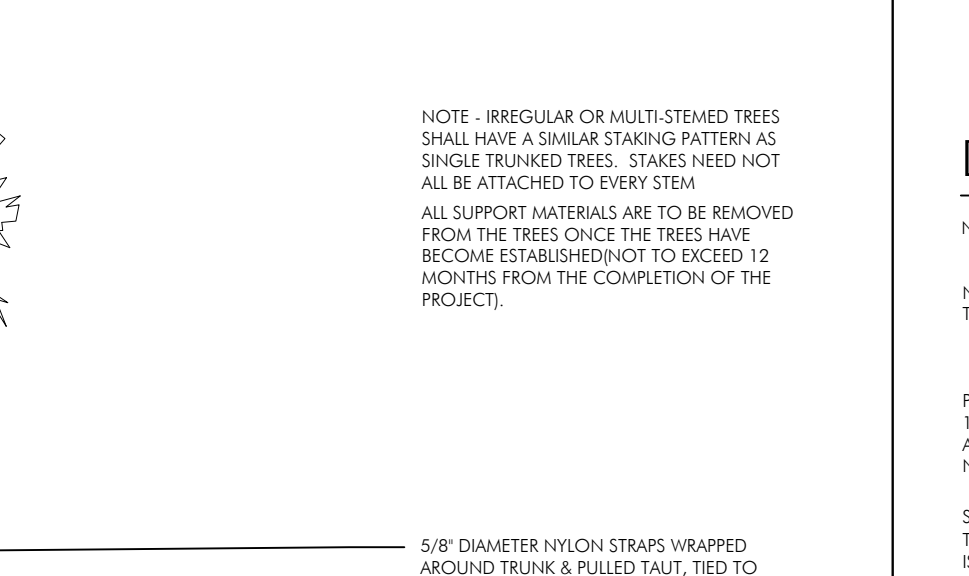
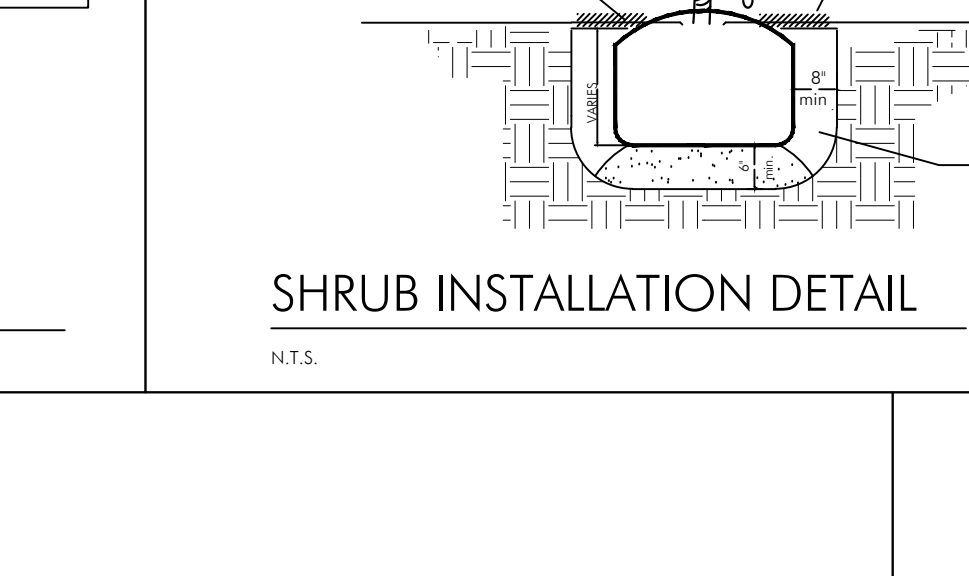
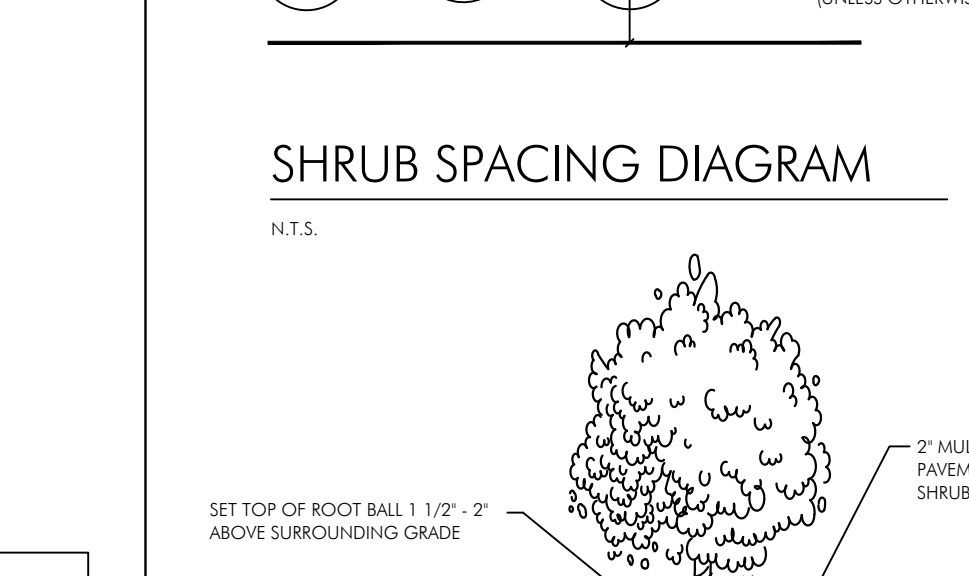
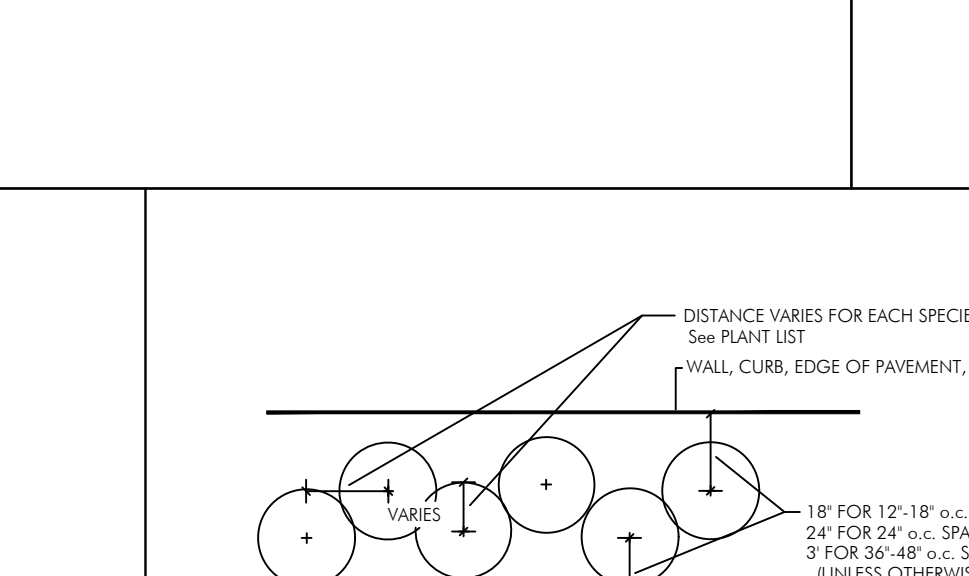
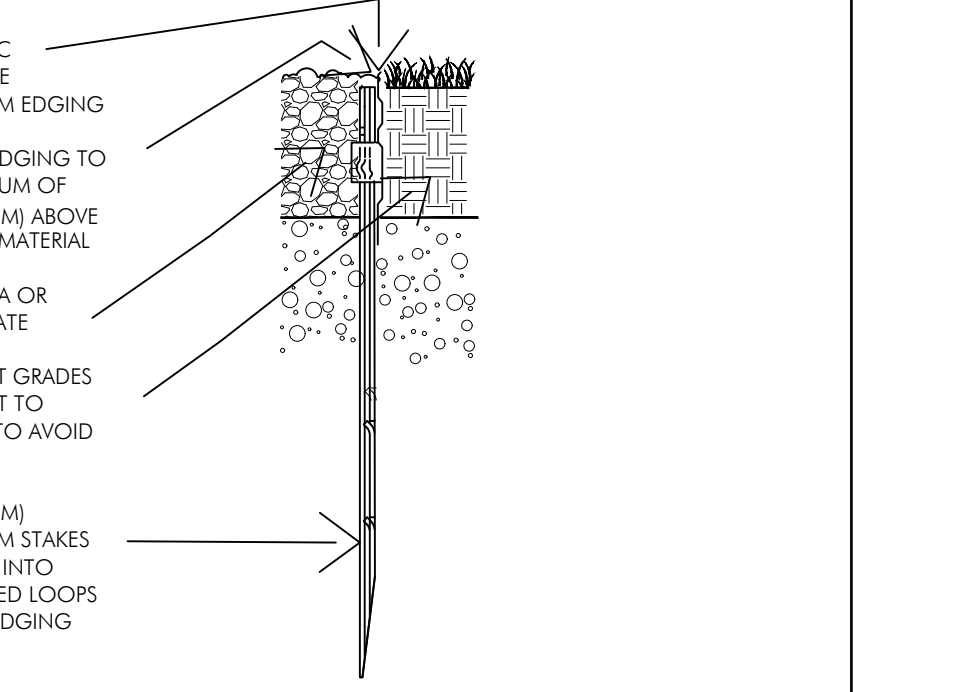
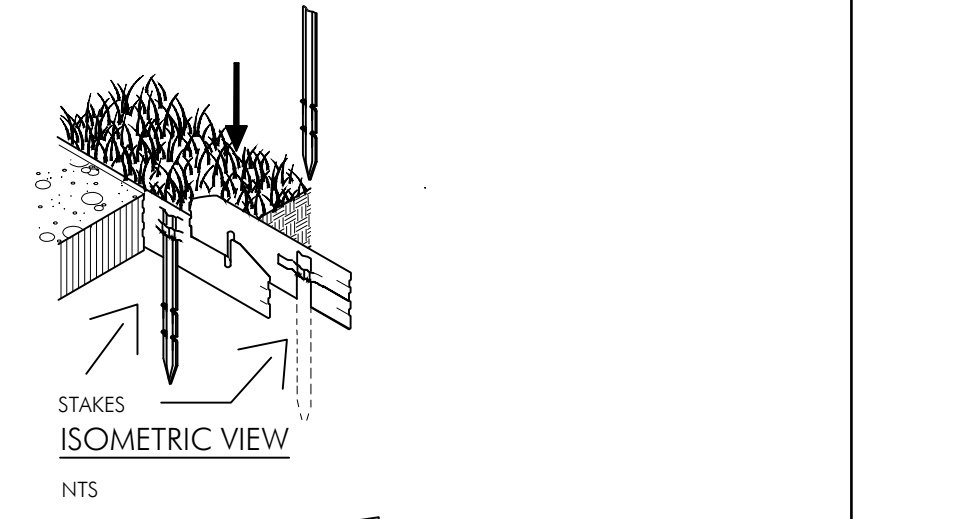

DETAIL A

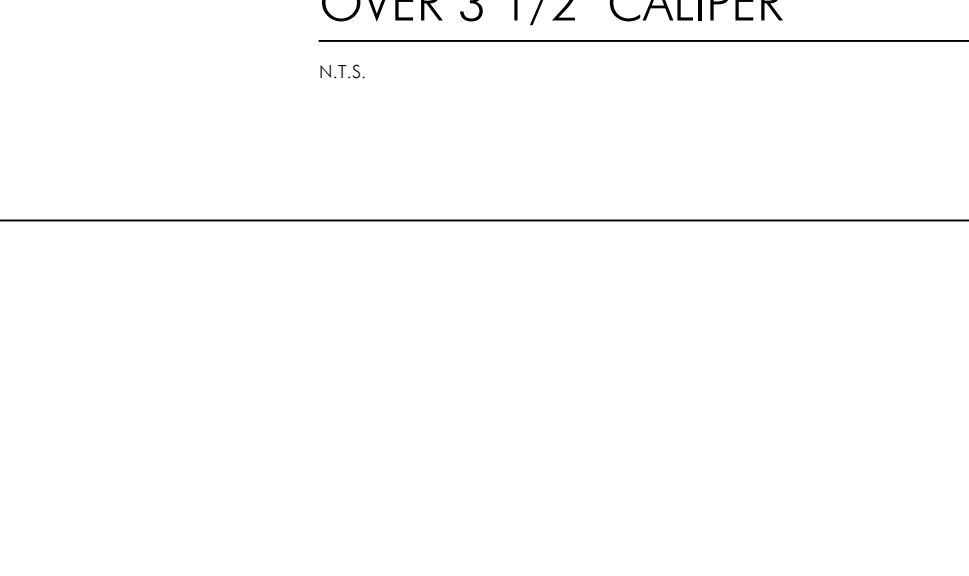
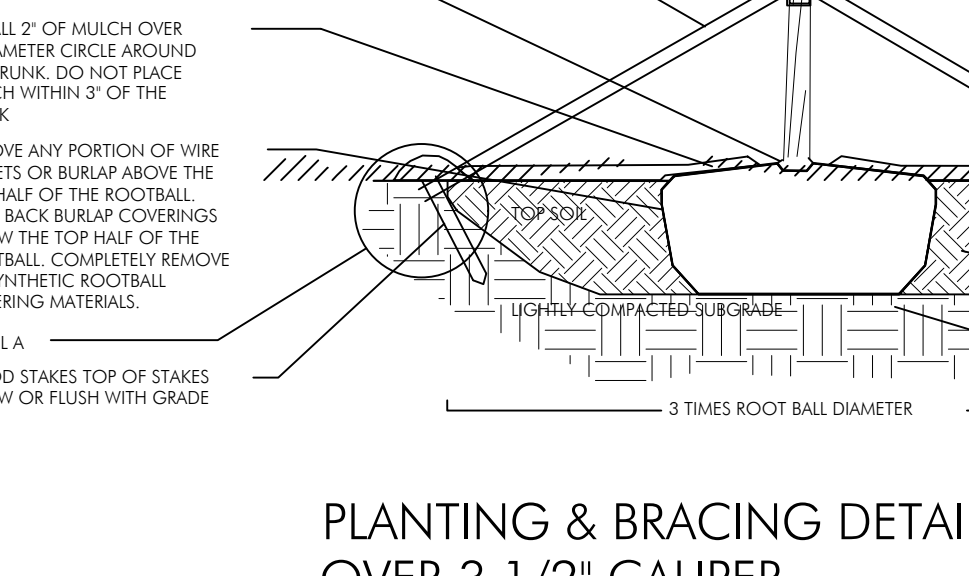
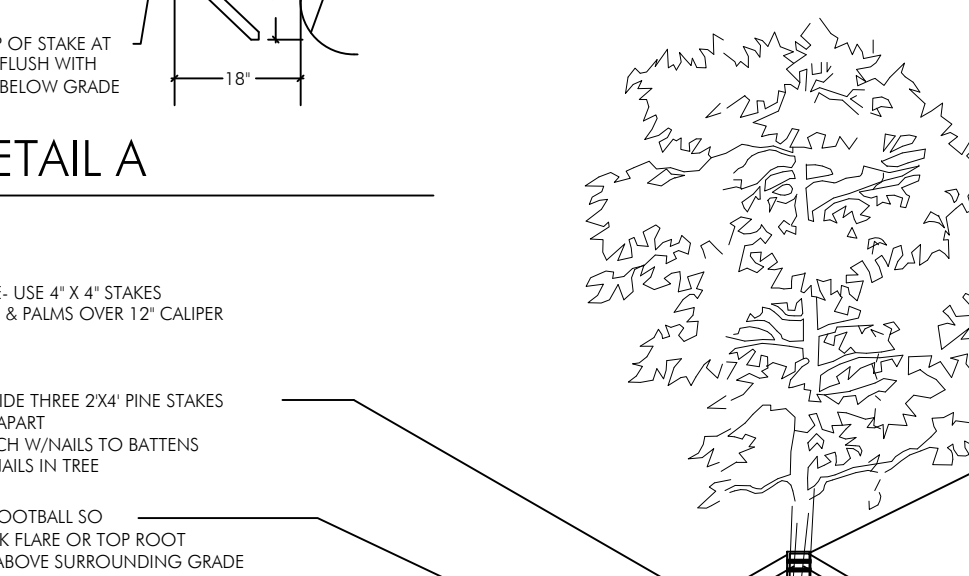
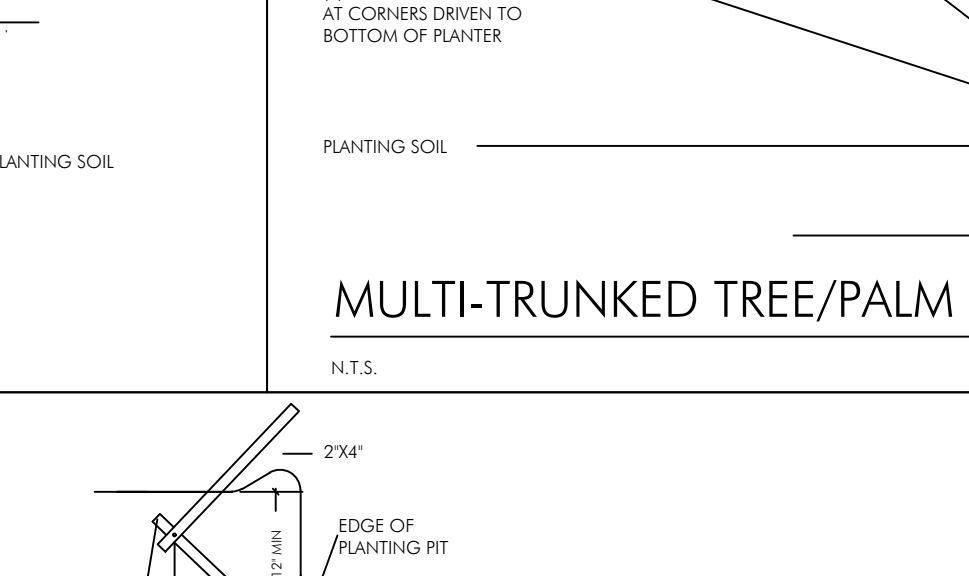
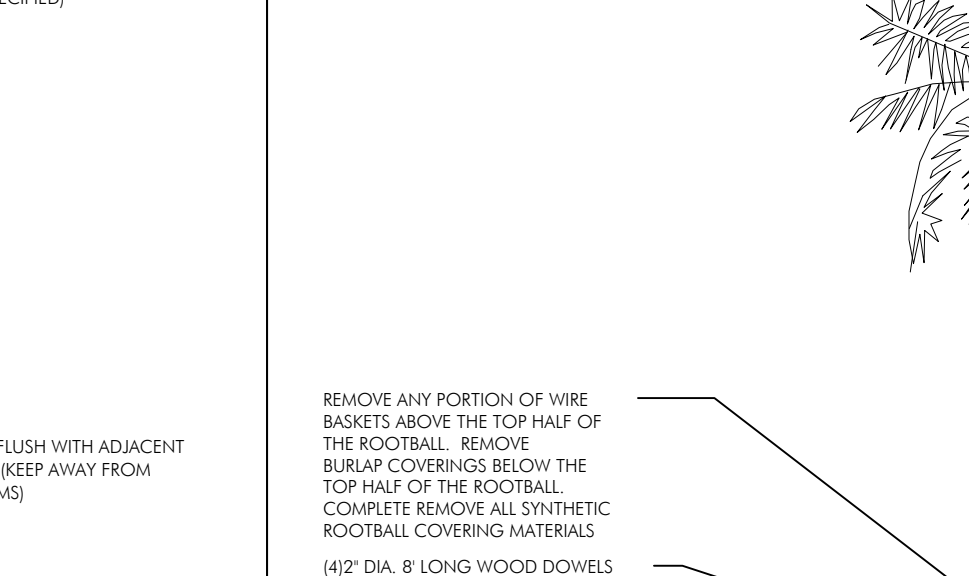
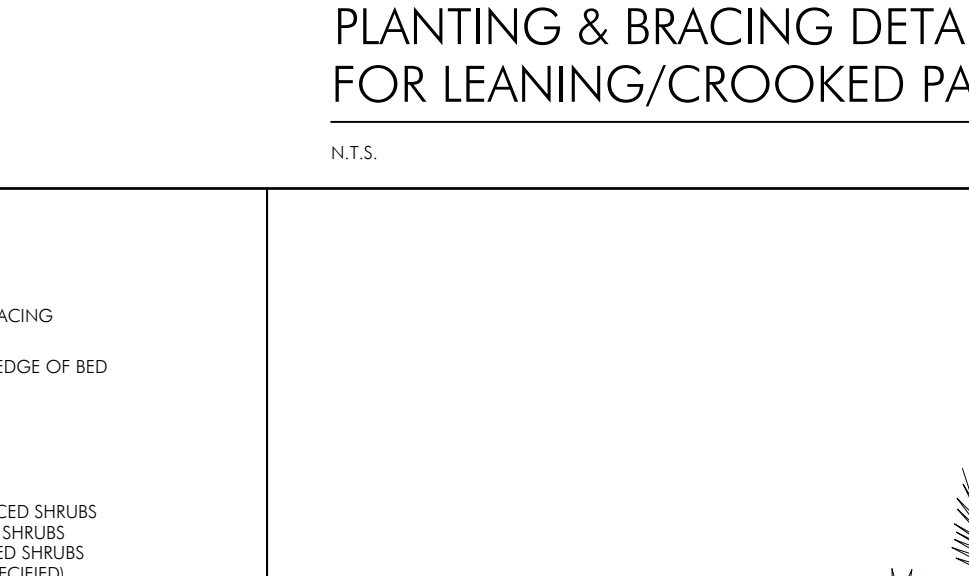
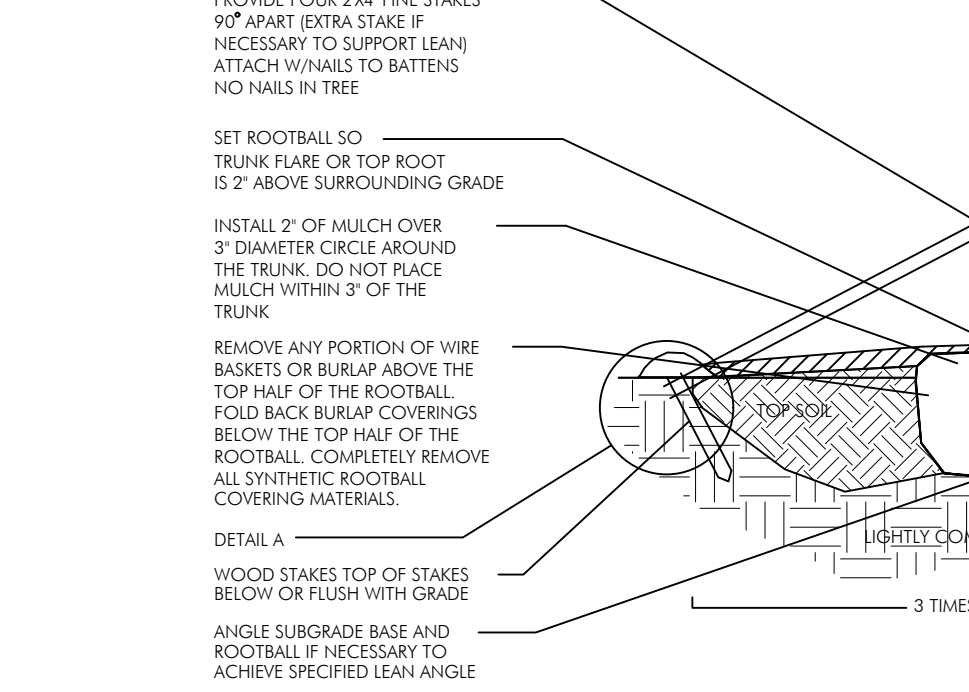
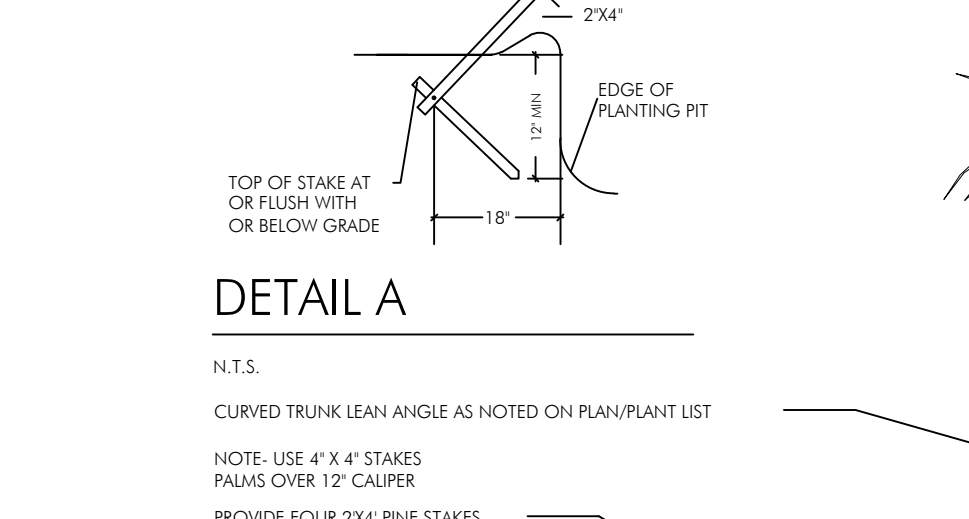

BATTEN DETAIL B

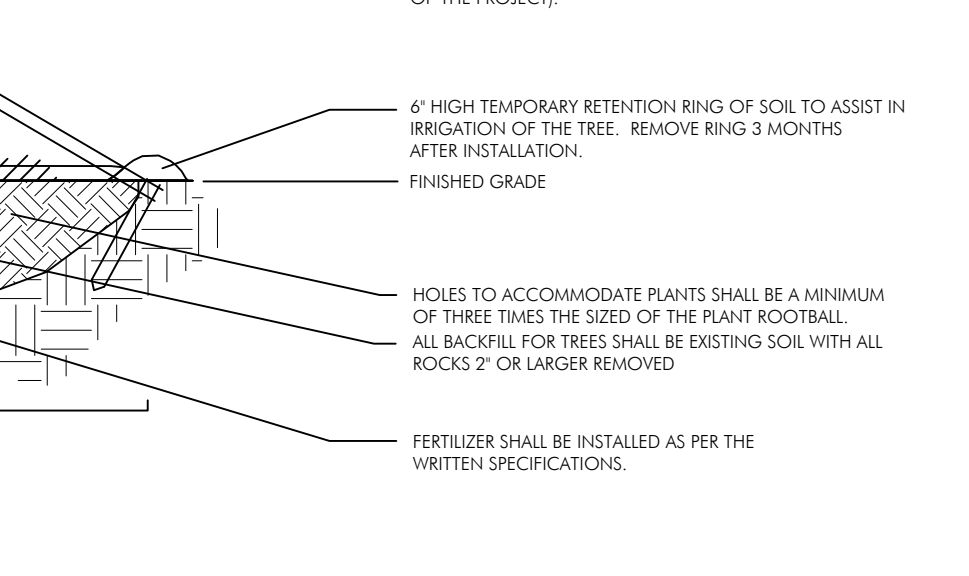
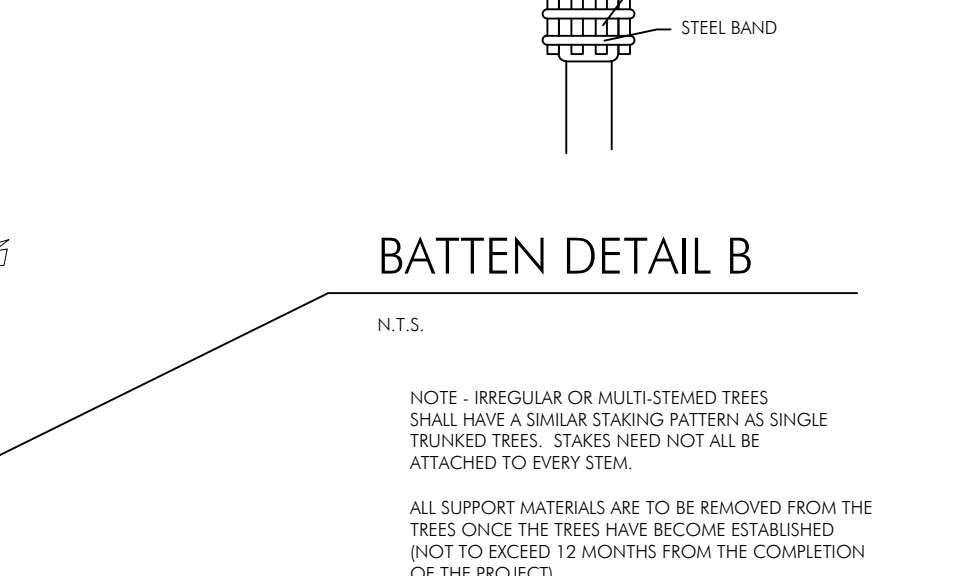
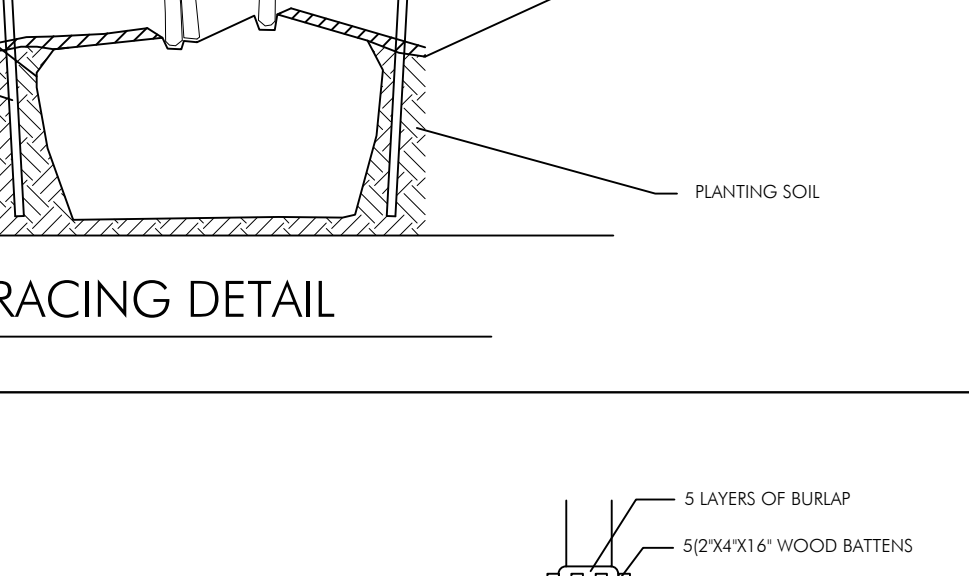
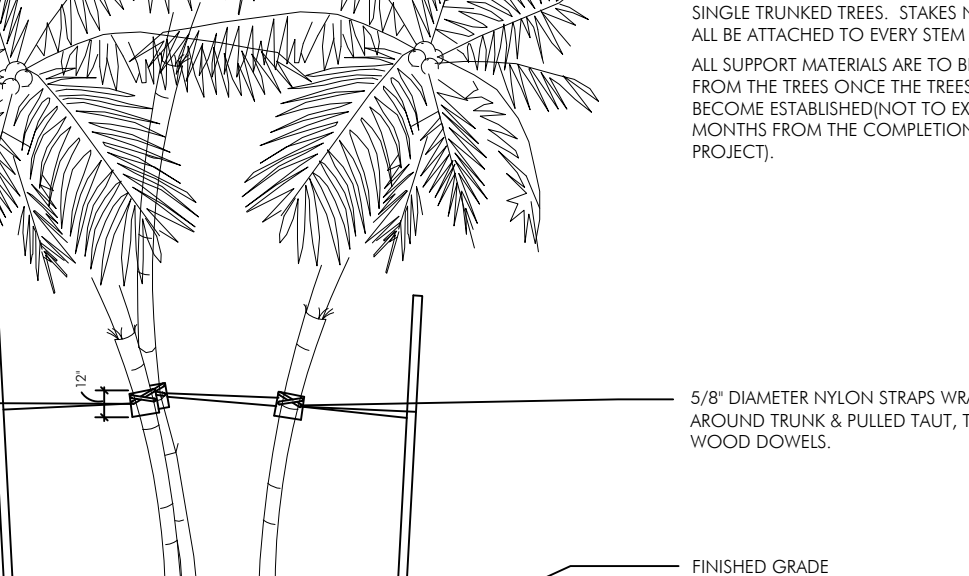
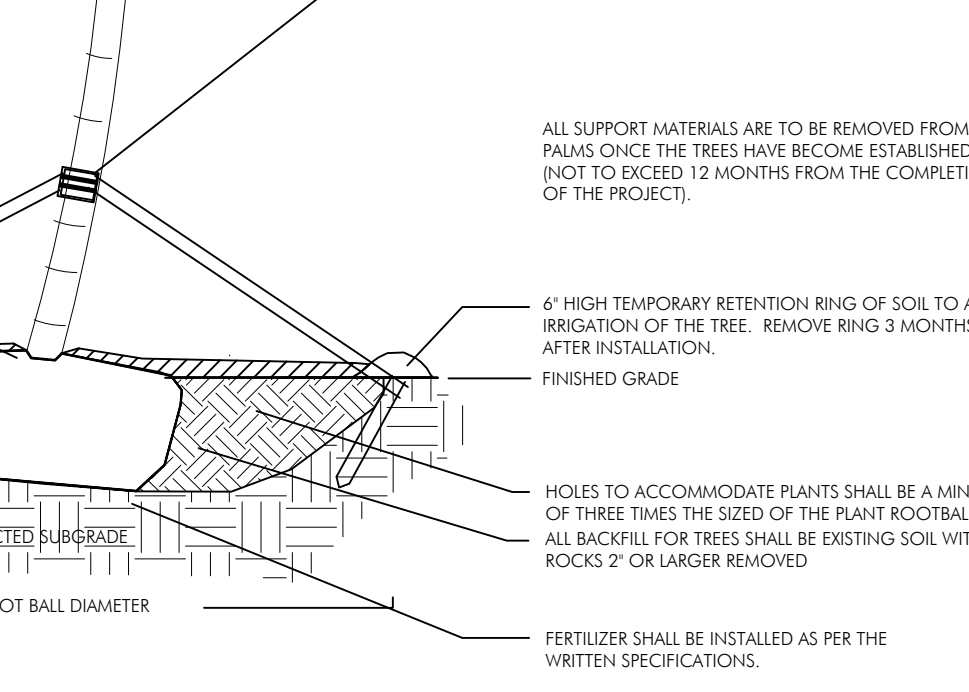
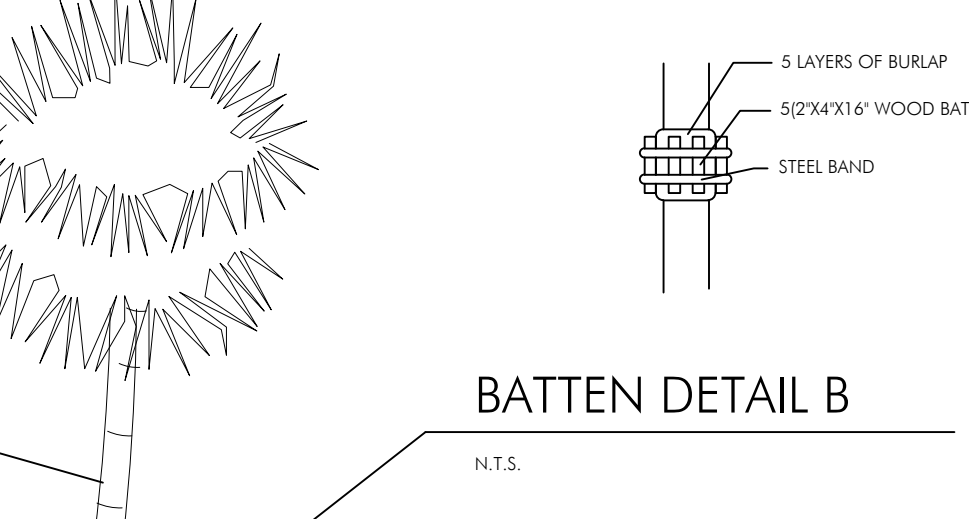

PLANTING & BRACING DETAIL FOR LEANING/CROOKED PALMS

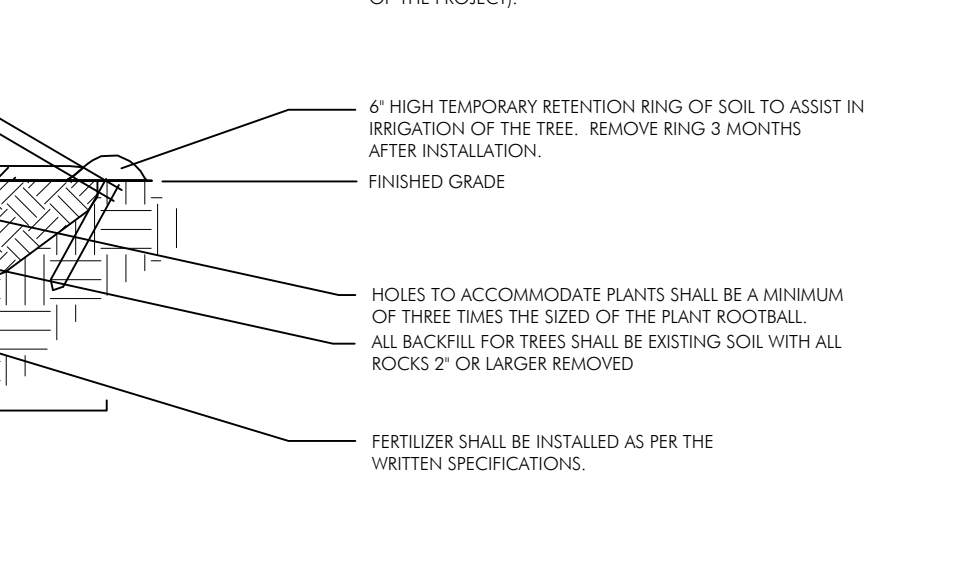
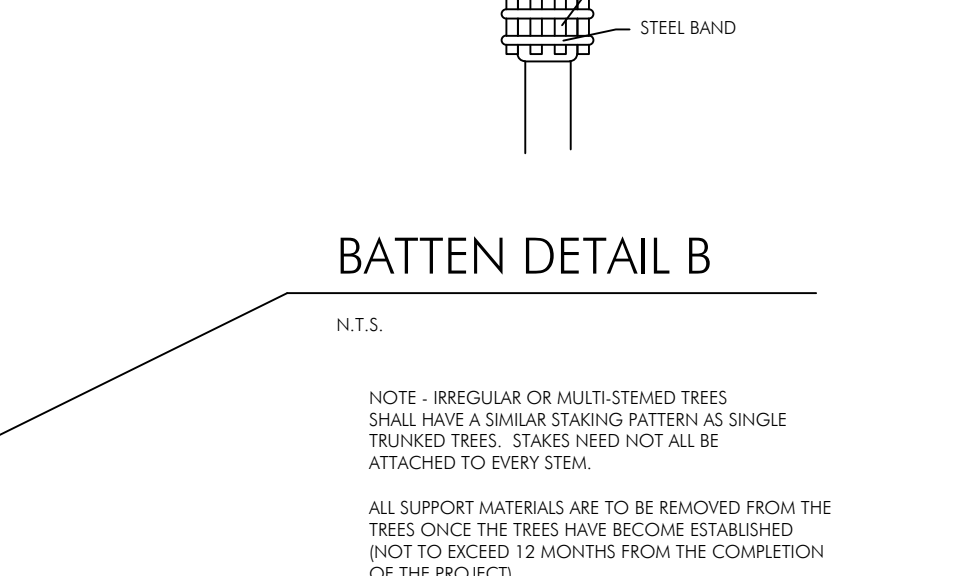
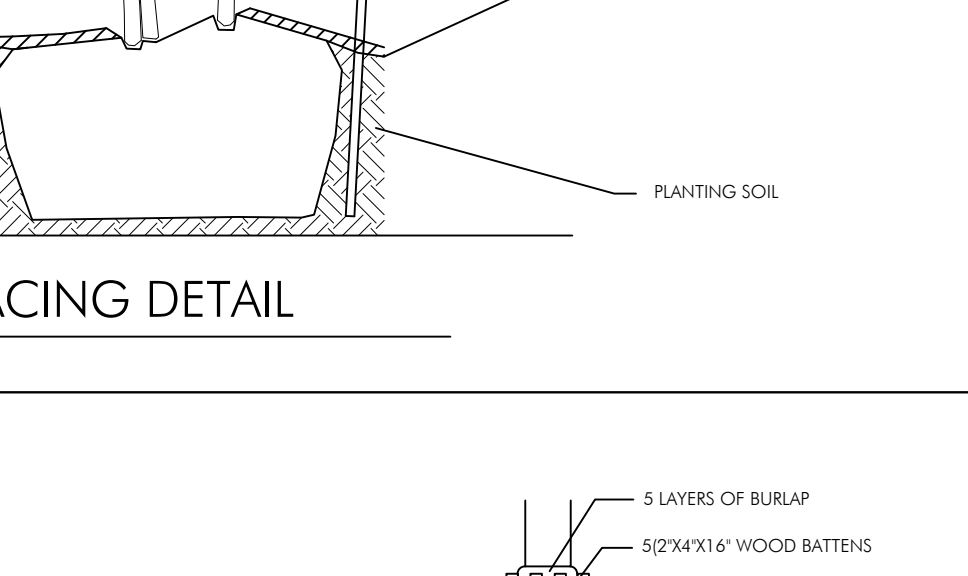
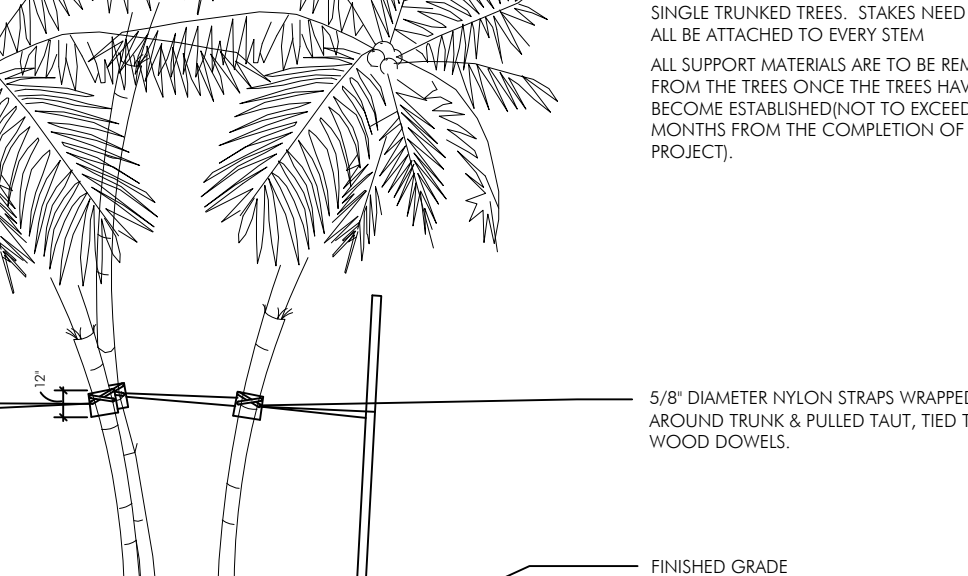
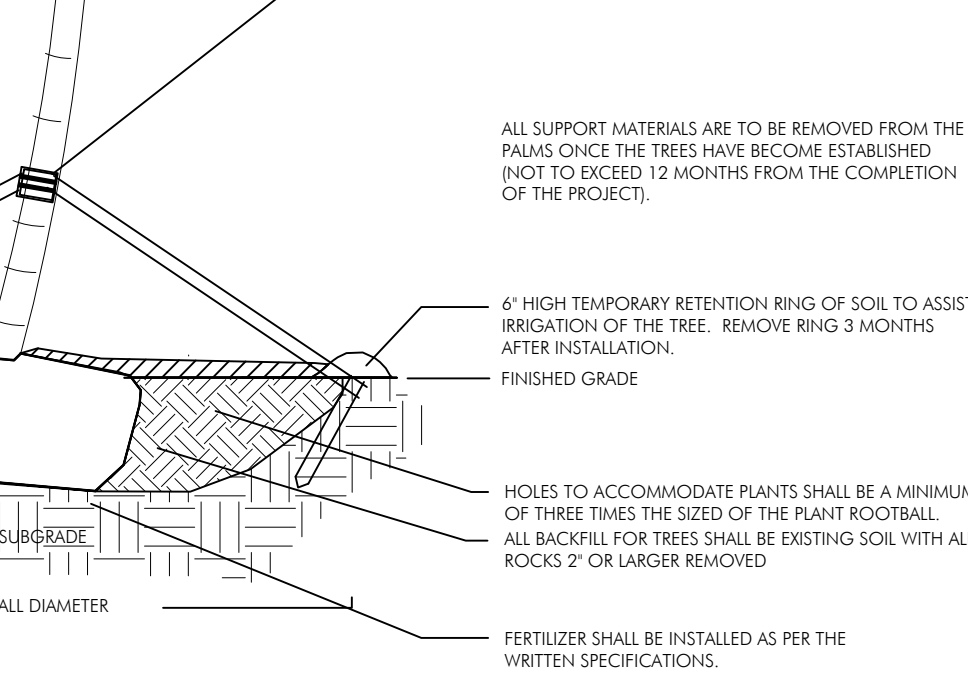
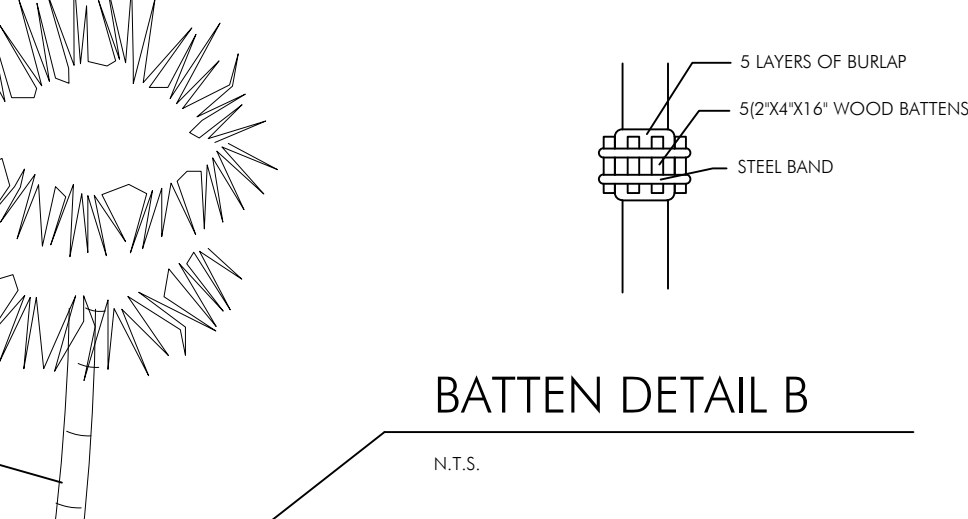

PLANTING & BRACING DETAIL UNDER 3 1/2" CALIPER

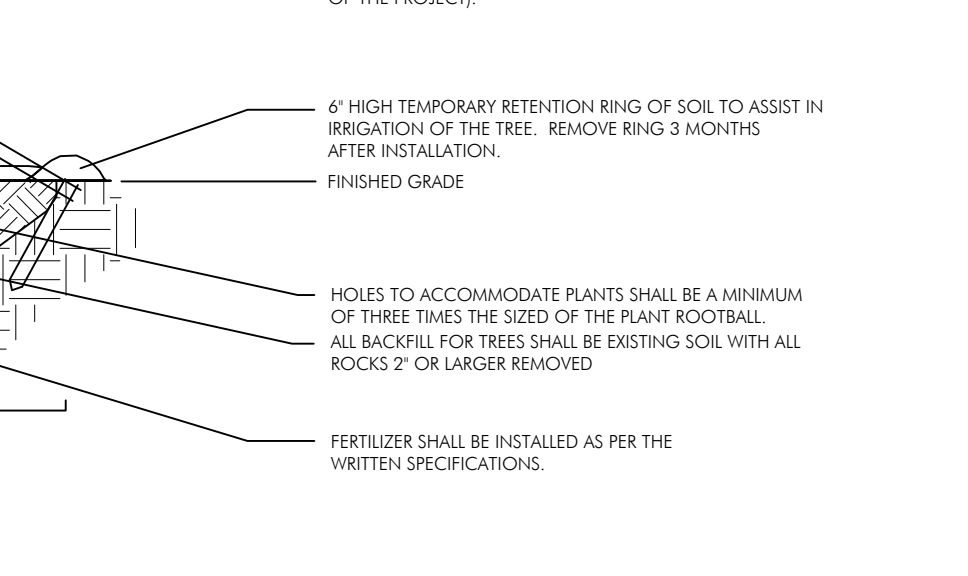
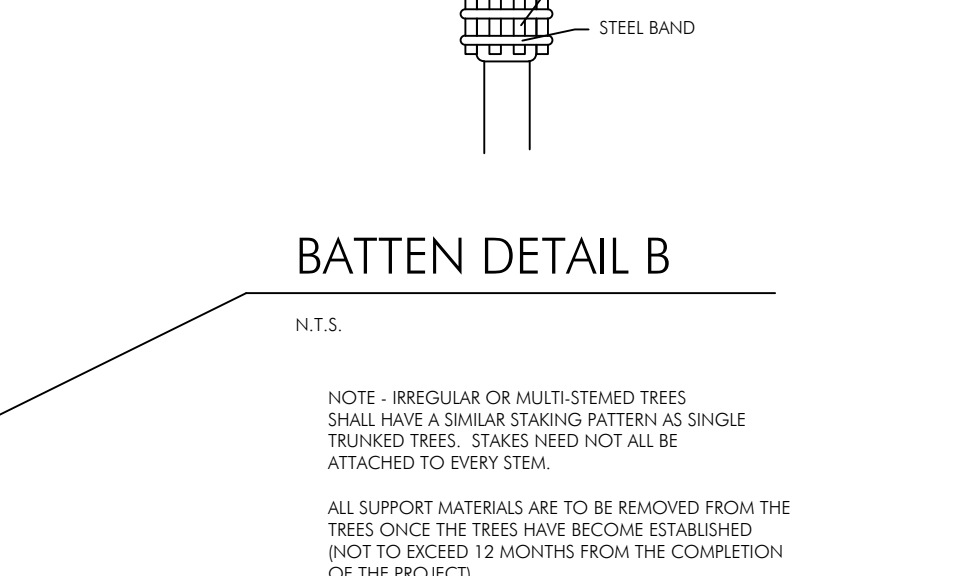
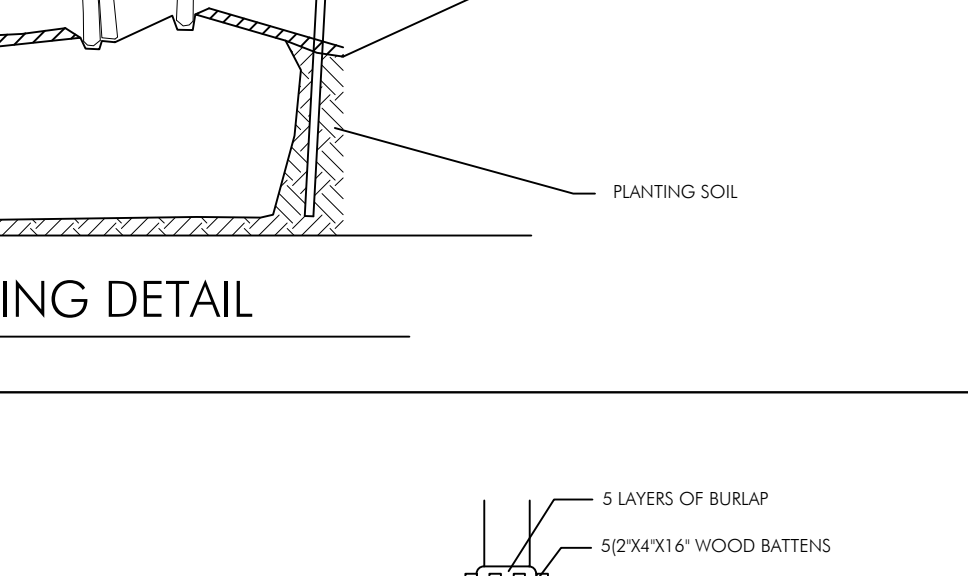
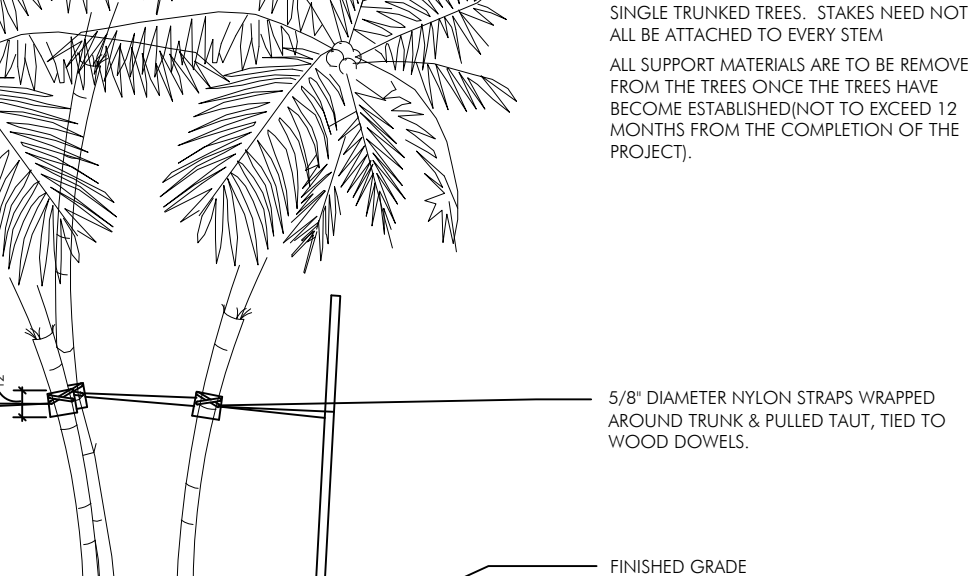
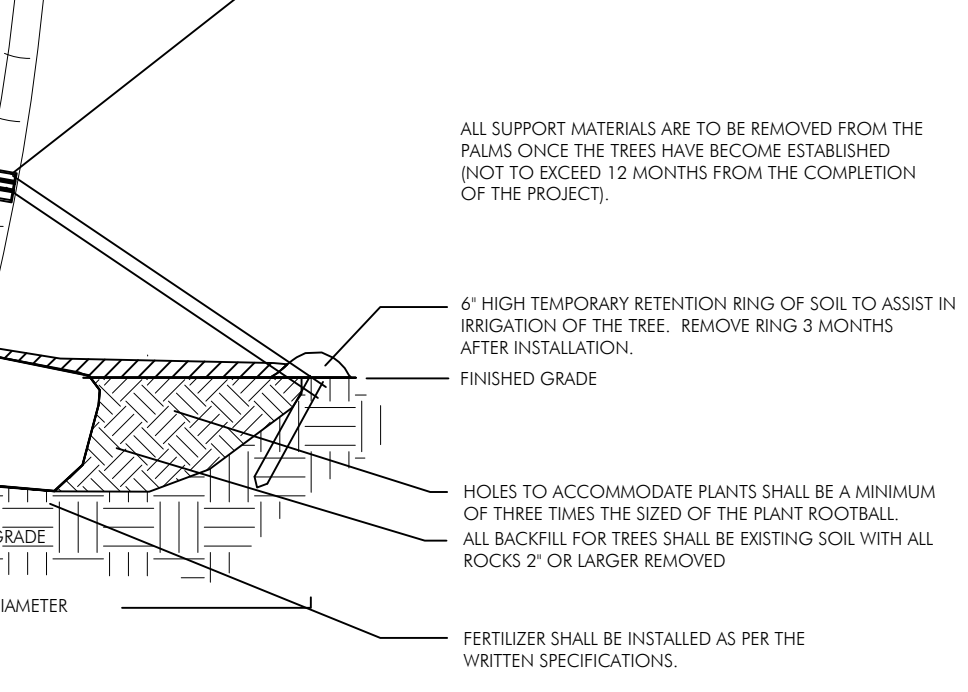
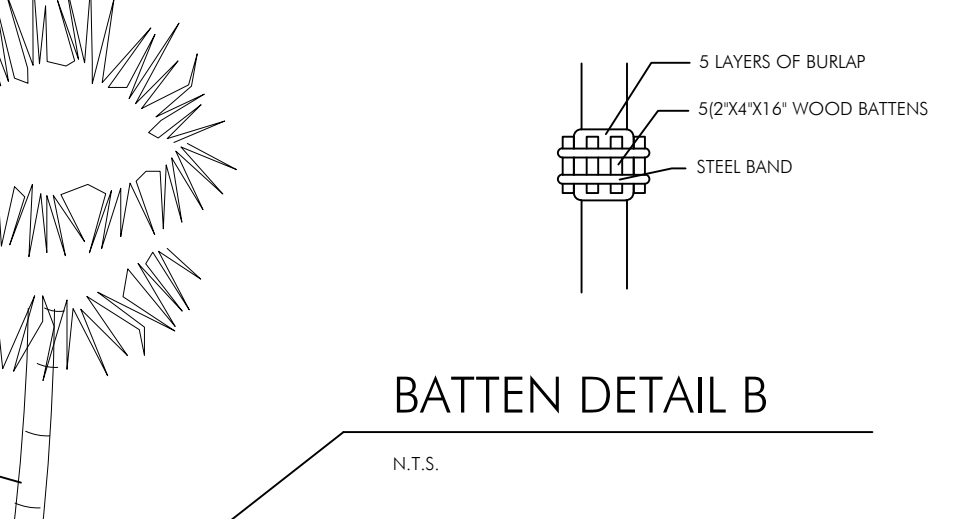

PLANTING & BRACING DETAIL OVER 3 1/2" CALIPER

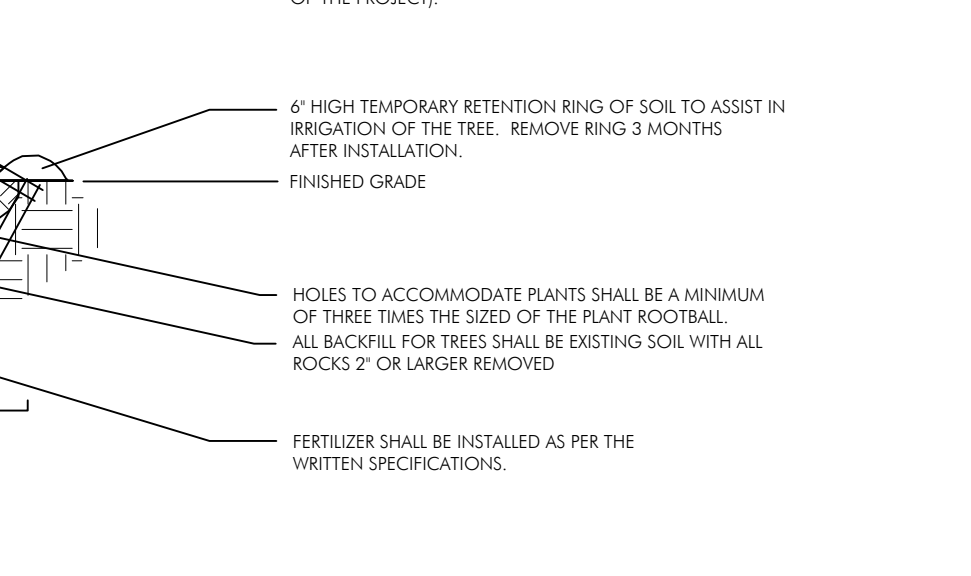
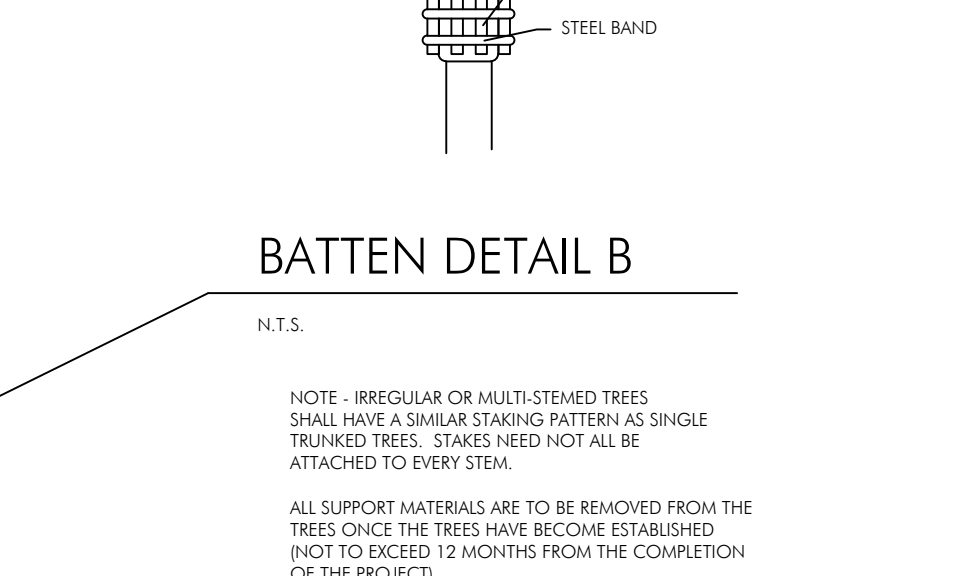
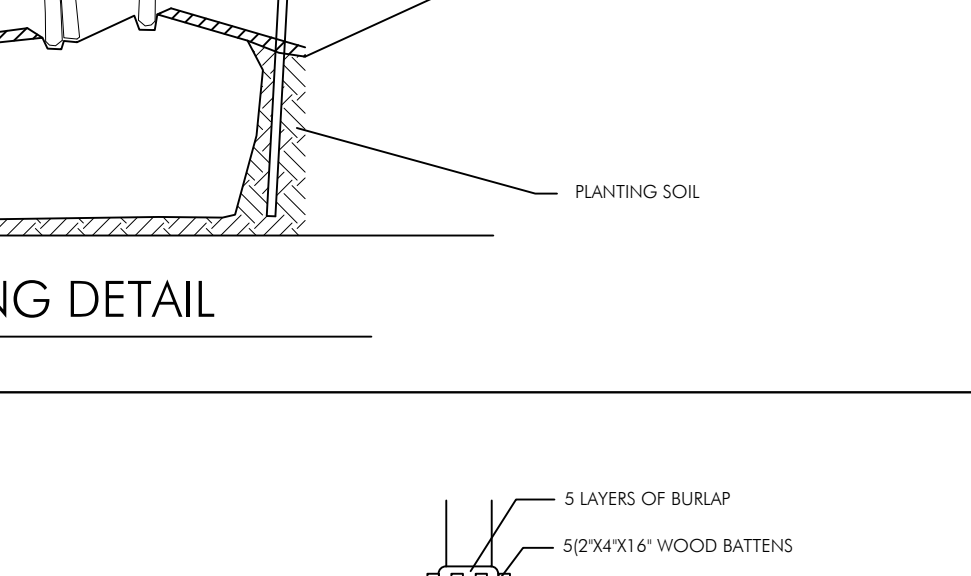
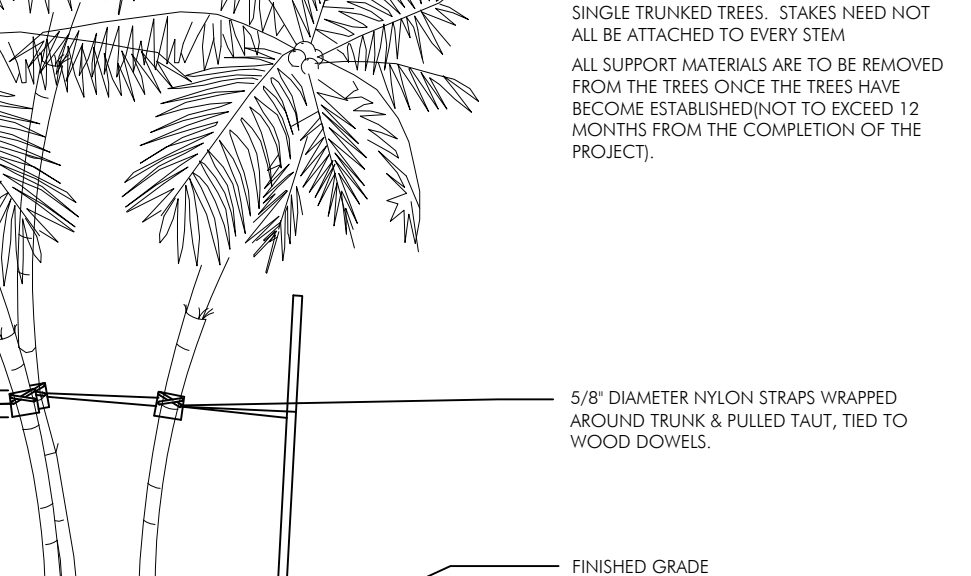
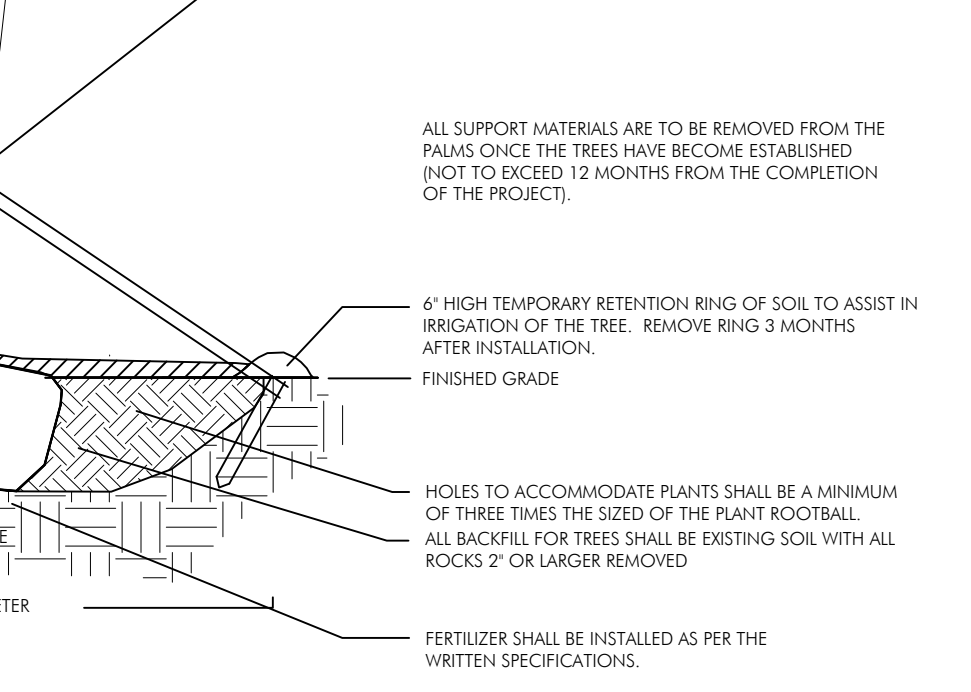
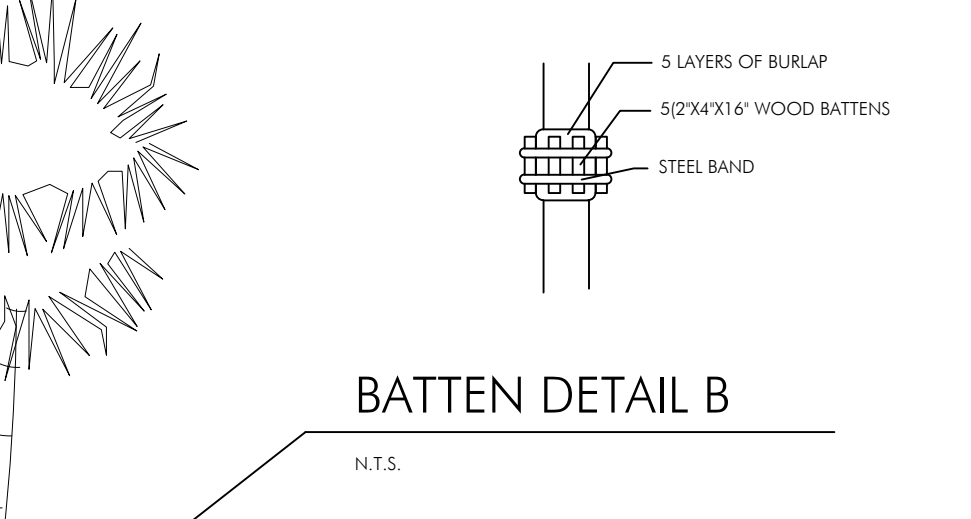

revuelta architecture internacional

Miami, Santiago, Chile

9850 BAY SW 57TH AVE SUITE 110 MIAMI, FL 33153

Project

1940 Bay Drive 1940 BAY DRIVE Miami Beach, Florida 33141

Revisions

Owner Information

#Client Company

#Client Address1 #Client Address2 #Client City, #Client State #Client Postcode

#Client Phone Number



Taylor Kiehl Semler PLA-FL667205

DRB SUBMITTAL

Date 08/04/2023

Scale AS SHOWN

Project No. 2133

Sheet No. PLANTING NOTES AND DETAILS

LA-501

NOT FOR CONSTRUCTION

These Drawings and Documents are the Copyright Property of Revuelta Architecture International, P.A. and may not be reproduced, copied, or transmitted in any form or by any means, electronic, mechanical, photocopying, recording, or by any information storage and retrieval system, without the prior written permission of Revuelta Architecture International, P.A. The information contained herein is for informational purposes only and does not constitute an offer of any financial product or service. All rights reserved. 08/04/2023

NOT FOR CONSTRUCTION

D

C

B

A

GENERAL NOTES:

- SCOPE OF WORK: The Contractor shall furnish all labor, machinery, tools, supplies, and equipment as necessary to construct and provide on operating system, as indicated in the Plans. The work shall include, but not be limited to, furnishing materials (pipe, valves, sprinkler heads, fittings, controllers, electrical, wire and fittings, primer, glue, etc.), layout, protection to the public, excavation, assembly, installation, backfilling, compaction, repair of road or pavement surfaces, controller and low voltage feed to the valves, clean-up, maintenance and guarantee, and as-built plans.
- Contractor shall coordinate with General Contractor or other pertinent Contractor on the job to insure that sleeves are provided and installed under hard surfaces to allow access to all areas to be irrigated. All sleeves shall be constructed of Schedule 40 PVC. Bury all sleeves a minimum of 24" below the surface. Sleeve to be 2 times the size of the pipe running through it. Sleeve shall extend 24" past the edge of pavement into the area to be irrigated.
- GUARANTEE: The irrigation system shall be guaranteed for a minimum of one calendar year from the time of final acceptance.
- REPAIR UTILITIES: The Contractor shall be responsible to verify the location of all utilities by hand excavation or other appropriate measures before performing any work that may result in damage to utilities structures, or property. The Contractor shall take immediate steps to repair, replace, or restore all services to any utilities which are disrupted due to his operations. All costs involved in disruption of service and repairs due to negligence on part of the Contractor shall be his responsibility.
- AS-BUILT DRAWINGS: Prints of the plans will be supplied to the Contractor for recording "as-built" information. Immediately upon installation of any work which deviates from what is shown on the Plans, the Contractor shall clearly indicate such changes in red pencil on the prints. Such changes shall include, but not be limited to, changes in (1) materials; (2) size of material; (3) location; and (4) quantities.
- The entire installation shall fully comply with all applicable local and state codes and ordinances. The Contractor shall take out all required plumbing and electrical applications and permits, arrange for all necessary inspections and shall pay of fees and expenses in connection with same as part of work under the contract.
- UNIT PRICES: The successful bidder shall furnish, to the Owner, a unit price breakdown for all materials. The Owner may at his own discretion, add to or delete from the materials, using the unit price breakdown submitted to and accepted by the Owner.
- MAINTENANCE PERIOD: The irrigation system shall be maintained for a period of 90 days after final acceptance of installation. Maintenance shall include checking of the system 2 times per week. Contractor shall be responsible to replace/repair any broken or malfunctioning parts of the system including those damaged by accident or vandalism. Repairs shall be made immediately at the time of inspection or when notified by the Landscape Architect.
- The irrigation system shall provide 100% coverage with a minimum of 90% overlap of water spray.
- The system is design to provide sprinkler precipitation rates that are nearly equal in each zone. Mixing of sprinklers with widely varying precipitation rates in a zone will not be accepted.
- All pipe shall be made of Schedule 40 PVC, except flexible PVC (or Tero pipe) for flexible swing joint and Schedule 80 galvanized steel pipe for all above ground fittings. Pipe locations shall be adjusted in the field. When using our mains and laterals, locate pipe near edges of pavement or against buildings wherever possible, to allow space for plant rootballs. Coordinate pipe locations with plantings. Bury all mains 18" below surface and laterals 12". Depth shall be measured to top of pipe.
- Keep pop-up sprinkler heads a minimum of 8" from edges of pavement and curbing, and heads on risers a minimum of 18", or as indicated in the plans.
- All heads located in shrub or groundcover beds shall be installed on a riser as per details in the plans. All other heads shall be installed on a swing joint as per details in the plans.
- Place irrigation control wire in conduit in the same trench as mains and under the main. All wire shall be #14 or larger solid copper (UL approved underground direct burial cable and shall be continuous with no splices from controller to solenoid valve).
- Valve locations are schematic and shall be adjusted in the field. Each valve shall be in a separate valve box (10" x 16" min.). When grouping valve boxes in grass or groundcover areas, set boxes a minimum of 12" apart to allow grass or groundcover to grow between them. When possible, side valve boxes in shrub beds, a minimum of 12" from edge of beds. Set all valve boxes, concrete or plastic, in ground with cover flush with finish grade, and level, with a minimum of 8" of pea gravel at the bottom of the box, with at least 2" of clearance from the bottom of the valve to the top of the gravel.
- TESTING: Notify the Landscape Architect in writing when testing will be conducted. Conduct test in the presence of the Landscape Architect. After all PVC assembly is completed the lines shall be flushed to insure that no rocks, sand, or other foreign debris remains in the lines. The mains shall be filled with water and all outlets shall be capped and plugged. The main shall be pressurized to 100 PSI for a minimum of one hour. No section of the main will be approved if the pressure drops more than 5 PSI at the end of the one hour period. Leaks shall be repaired immediately and the system shall be re-tested until found satisfactory by the Landscape Architect.

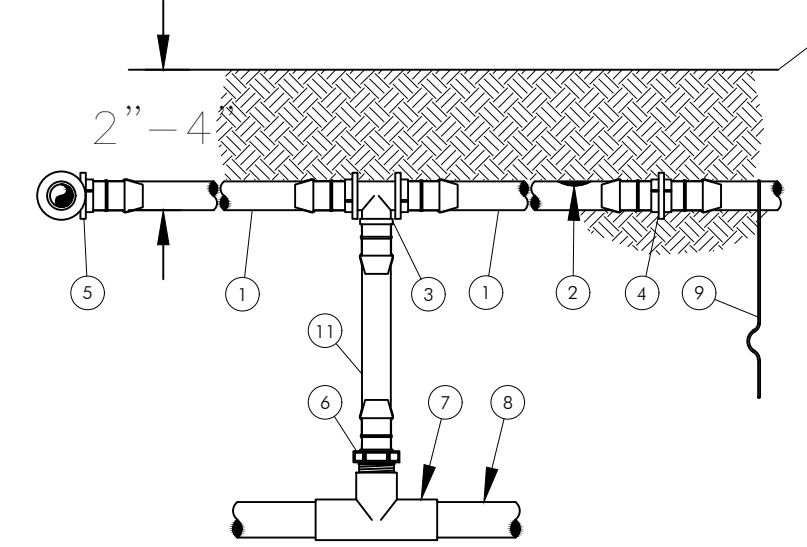

- ON SURFACE DRIPLINE: RAIN BRD OF SERIES DRIPLINE POTABLE: XFS DRIPLINE NON-POTABLE: XFS DRIPLINE
- INLINE DRIP EMITTER OUTLET, SEE PLANS FOR DRIPLINE OUTLET SPACING.
- BARB TEE 1 1/2" x 1/2" RAIN BRD XFD-TEE
- BARB COUPLING 1 1/2" RAIN BRD XFD-COUP
- BARB ELBOW 1 1/2" RAIN BRD XFD-ELBOW
- BARB MALE ADAPTER 1 1/2" x 1/2" RAIN BRD XFD-MA-050 1 1/2" x 3/4" RAIN BRD XFD-MA-075
- PVC TEE SOGT
- PVC LATERAL SUPPLY HEADER
- THE DOWN STAKE: RAIN BRD TDS-050 WITH BEND (TYPICAL)
- FINISH GRADE
- RAIN BRD OF SERIES BLANK TUBING LENGTH AS REQUIRED

XFS SUBSURFACE DRIPLINE RISER ASSEMBLY

N.T.S.

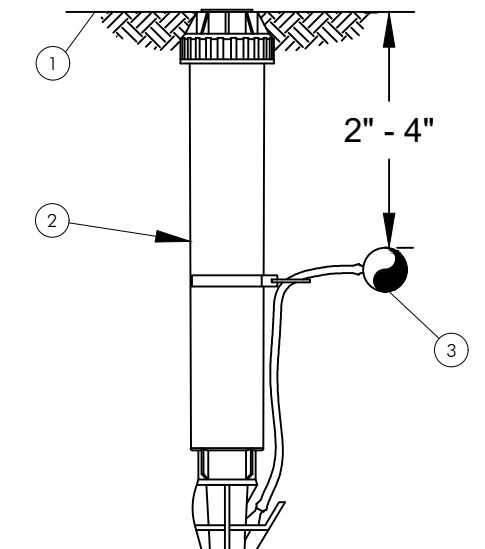

- FINISH GRADE/TURF
- OPERATION INDICATOR RAIN BRD MODEL OPERIND
- SUBSURFACE DRIPLINE: RAIN BRD OF SERIES DRIPLINE POTABLE: XFS DRIPLINE NON-POTABLE: XFS DRIPLINE

XFS SUBSURFACE DRIPLINE OPERATION INDICATOR

N.T.S.

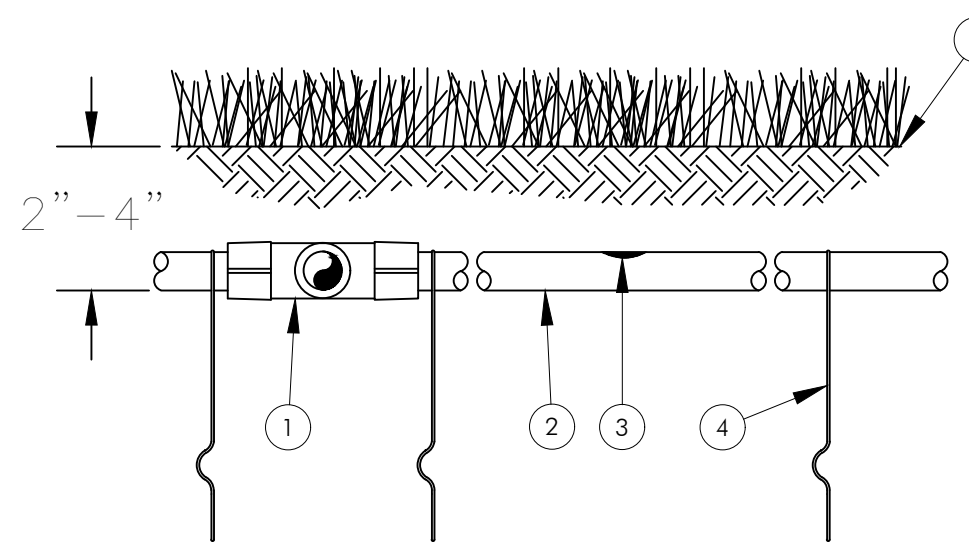

- EASY FIT COMPRESSION TEE: RAIN BRD ADCFTEE
- SUBSURFACE DRIPLINE: RAIN BRD OF SERIES DRIPLINE POTABLE: XFS DRIPLINE NON-POTABLE: XFS DRIPLINE
- INLINE DRIP EMITTER
- THE DOWN STAKE: RAIN BRD TDS-050 WITH BEND (TYPICAL)
- TURF/FINISH GRADE OR SHRUB BED WITH MULCH

XFS SUBSURFACE DRIPLINE BURIAL

N.T.S.

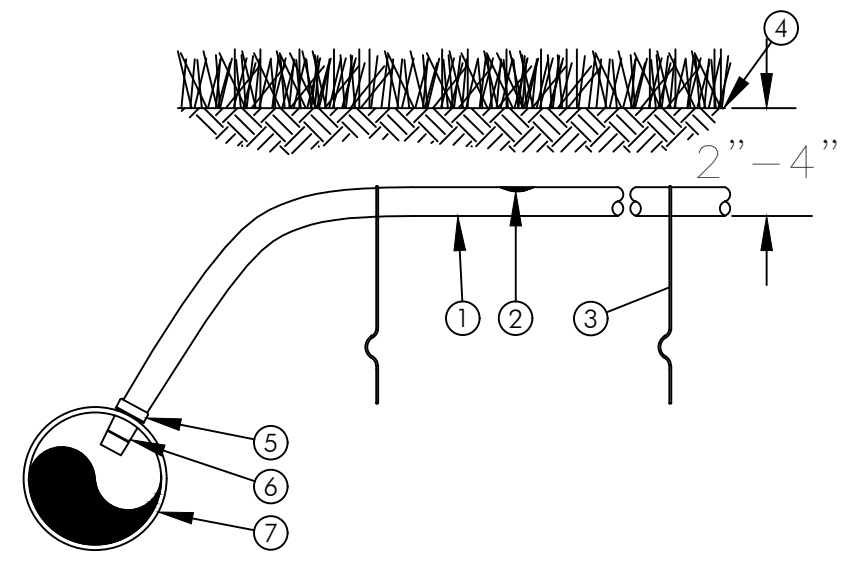

- SUBSURFACE DRIPLINE: RAIN BRD OF SERIES DRIPLINE POTABLE: XFS DRIPLINE NON-POTABLE: XFS DRIPLINE
- INLINE DRIP EMITTER OUTLET
- THE DOWN STAKE: RAIN BRD TDS-050 WITH BEND (TYPICAL)
- TURF/FINISH GRADE OR SHRUB BED WITH MULCH
- RATCHET CLAMP (INCLUDED WITH ADAPTER)
- INSERT ADAPTER FOR PVC PIPE: RAIN BRD XFD-IN-PVC
- PVC LATERAL PIPE MINIMUM 1 1/2" IN DIAMETER DEPTH PER SPECIFICATION

XFS SUBSURFACE DRIPLINE ADAPTER FOR PVC

N.T.S.

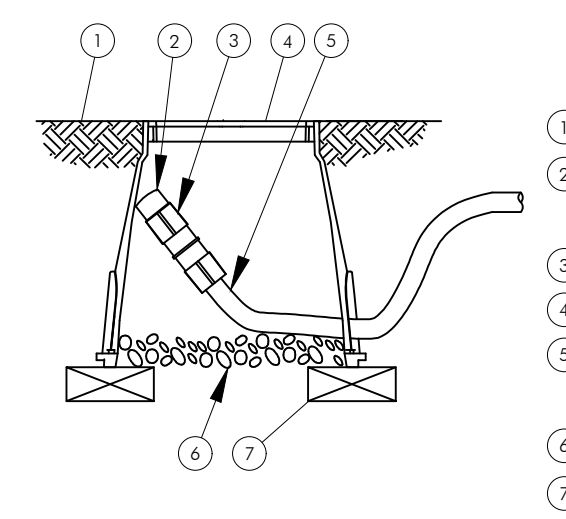

- FINISH GRADE
- FLUSH CAP FOR EASY FIT COMPRESSION FITTINGS: POTABLE: RAIN BRD HDXFCAP NON-POTABLE: RAIN BRD HDXFCAP
- EASY FIT COUPLING: RAIN BRD HDXCOUP
- SUBSURFACE DRIPLINE: RAIN BRD OF SERIES DRIPLINE POTABLE: XFS DRIPLINE NON-POTABLE: XFS DRIPLINE
- 3-INCH MINIMUM DEPTH OF 3/4-INCH WASHED GRAVEL
- BRICK (1 OF 2)

XFS DRIPLINE FLUSHPOINT WITH COMPRESSION FITTINGS

N.T.S.

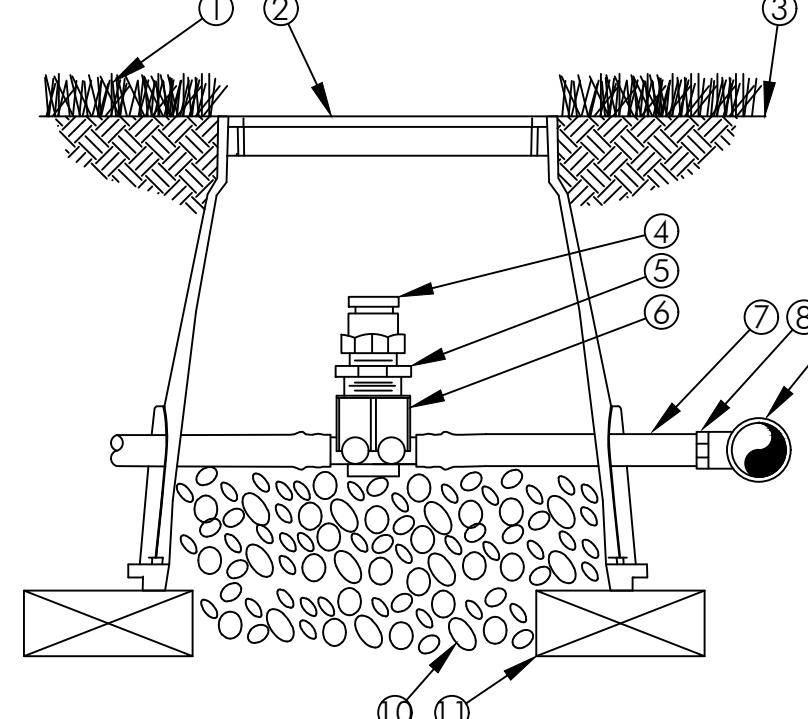

- TURF GRASS
- SUBSURFACE DRIPLINE: RAIN BRD OF SERIES DRIPLINE POTABLE: XFS DRIPLINE NON-POTABLE: XFS DRIPLINE
- FINISH GRADE
- AIR RELIEF VALVE: RAIN BRD ARV050 TO BE INSTALLED AT HIGH POINTS IN DRIP ZONE
- 1/2" x 1/2" PVC REDUCER BUSHING
- BARB X FEMALE THREAD CONNECTOR: RAIN BRD XFD-TA FITTING
- BLANK DRIPLINE TUBING: RAIN BRD OF SERIES
- BARB X MALE THREAD CONNECTOR: RAIN BRD XFD-MA FITTING
- PVC TEE CONNECTED TO PVC HEADER PIPE
- 3" MINIMUM DEPTH OF 3" WASHED GRAVEL
- BRICK (1 OF 2)

XFS AIR/VACUUM RELIEF

N.T.S.

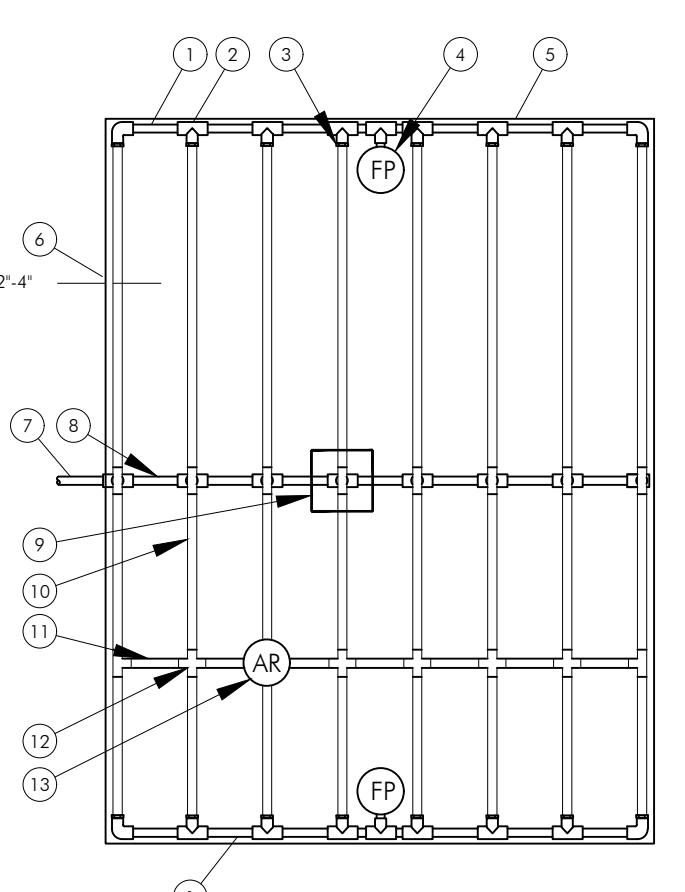

- PVC EXHAUST HEADER
- PVC SCH 40 TEE OR EL (TYPICAL)
- BARB X MALE FITTING: RAIN BRD XFD-MA FITTING (TYPICAL)
- FLUSH POINT (TYPICAL)
- PERIMETER OF AREA
- PERIMETER DRIPLINE PIPE TO BE INSTALLED 2'-4" FROM PERIMETER OF AREA
- PVC SUPPLY PIPE FROM RAIN BRD CONTROL ZONE (FIT SIZED TO MEET LATERAL FLOW DEMAND)
- PVC SUPPLY MANIFOLD
- CONNECTION FROM SUPPLY MANIFOLD TO DRIPLINE (TYPICAL); SEE INSET A
- SUBSURFACE DRIPLINE: RAIN BRD OF SERIES DRIPLINE POTABLE: XFS DRIPLINE NON-POTABLE: XFS DRIPLINE
- RAIN BRD OF SERIES BLANK TUBING
- BARB X BARB INSERT TEE OR CROSS: RAIN BRD XFD-TEE OR RAIN BRD XFD-CROSS (TYPICAL)
- AIR RELIEF VALVE: RAIN BRD MODEL ARV050
- SEE RAIN BRD XFS DETAILS FOR AIR RELIEF INSTALLATION
- BARB X FEMALE FITTINGS: RAIN BRD XFD-TA FITTING
- 1/2" PVC NIPPLE, LENGTH AS NECESSARY

Inlet Pressure psi	12" Spacing		18" Spacing		24" Spacing	
	Nominal Flow (gph)	Normal Flow (gph)	Nominal Flow (gph)	Normal Flow (gph)	Nominal Flow (gph)	Normal Flow (gph)
15	273	155	314	200	424	322
20	318	169	353	224	508	368
30	360	230	413	350	586	414
40	395	295	465	402	652	474
50	417	285	528	420	720	488
60	460	290	596	455	780	514

XFS SUBSURFACE DRIPLINE CENTERFEED LAYOUT

N.T.S.

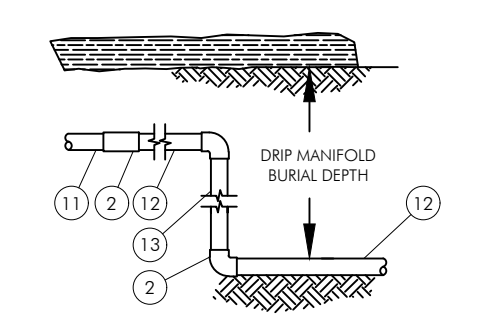

- PVC EXHAUST HEADER
- PVC SCH 40 TEE OR EL (TYPICAL)
- BARB X MALE FITTING: RAIN BRD XFD-MA FITTING (TYPICAL)
- FLUSH POINT (TYPICAL)
- RAIN BRD OF SERIES BLANK TUBING
- PERIMETER OF AREA
- PERIMETER DRIPLINE PIPE TO BE INSTALLED 2'-4" FROM PERIMETER OF AREA
- SUBSURFACE DRIPLINE: RAIN BRD OF SERIES DRIPLINE POTABLE: XFS DRIPLINE NON-POTABLE: XFS DRIPLINE
- RAIN BRD OF SERIES BLANK TUBING
- BARB X BARB INSERT TEE OR CROSS: RAIN BRD XFD-TEE OR RAIN BRD XFD-CROSS (TYPICAL)
- AIR RELIEF VALVE: RAIN BRD MODEL ARV050
- SEE RAIN BRD XFS DETAILS FOR AIR RELIEF INSTALLATION
- PVC SUPPLY HEADER
- PVC DRIP MANIFOLD FROM RAIN BRD CONTROL ZONE VALVE (FIT SIZED TO MEET LATERAL FLOW DEMAND)
- PVC SCH 40 RISER PIPE

Inlet Pressure psi	12" Spacing		18" Spacing		24" Spacing	
	Nominal Flow (gph)	Normal Flow (gph)	Nominal Flow (gph)	Normal Flow (gph)	Nominal Flow (gph)	Normal Flow (gph)
15	273	155	314	200	424	322
20	318	169	353	224	508	368
30	360	230	413	350	586	414
40	395	295	465	402	652	474
50	417	285	528	420	720	488
60	460	290	596	455	780	514

XFS SUBSURFACE DRIPLINE END FEED LAYOUT

N.T.S.

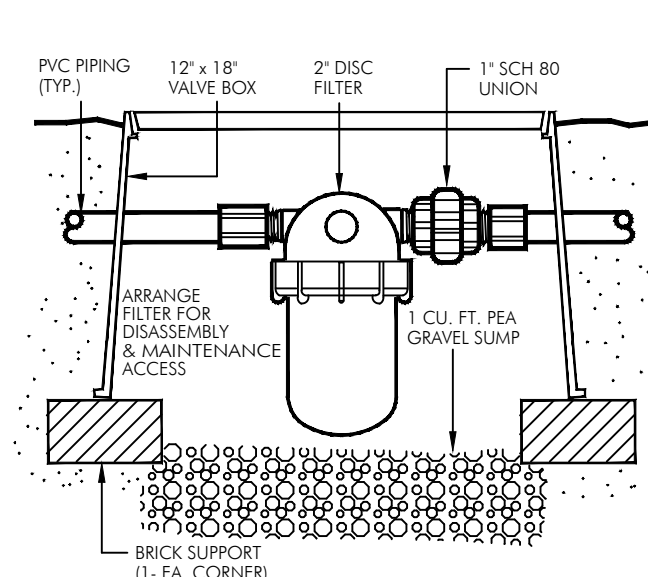

- PVC RING (TYP)
- 1 1/2" x 1" VALVE BOX
- 2" DISC FILTER
- 1" SCH 80 MUNCH
- ARRANGE FILTER FOR EASY ACCESS & MAINTENANCE (NO MAINTENANCE REQUIRED)
- 1" DIA. GRAVEL SLUMP
- BRICK SUPPORT (1 EA. CORNER)

2" DISC FILTER

N.T.S.

RAIN SENSOR DETAIL

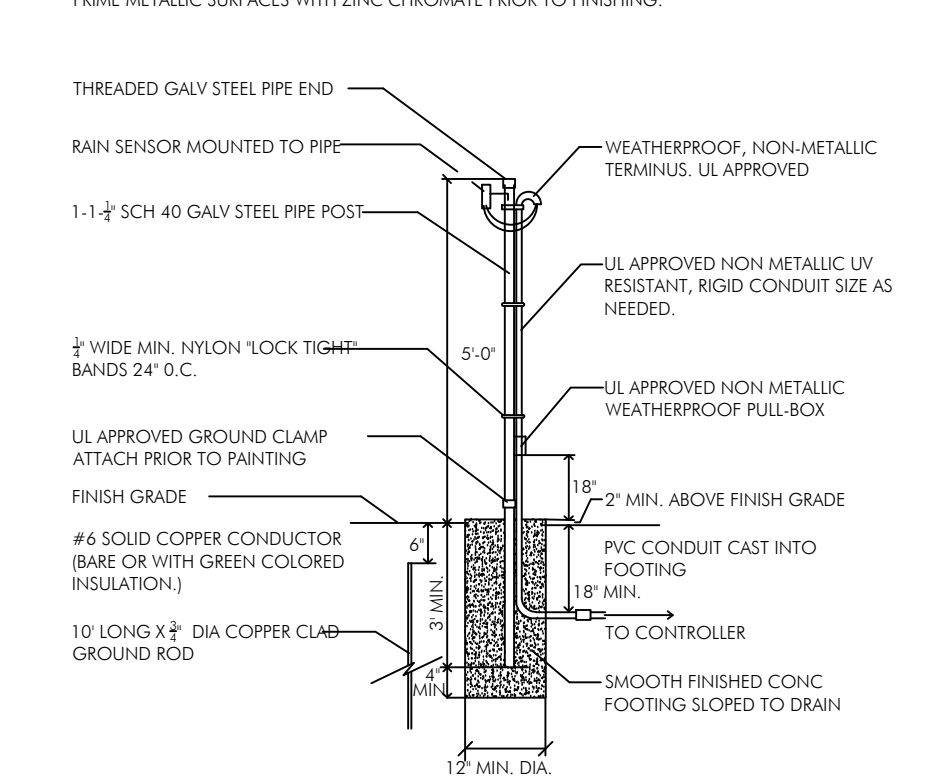

RAIN SENSOR DETAIL

N.T.S.

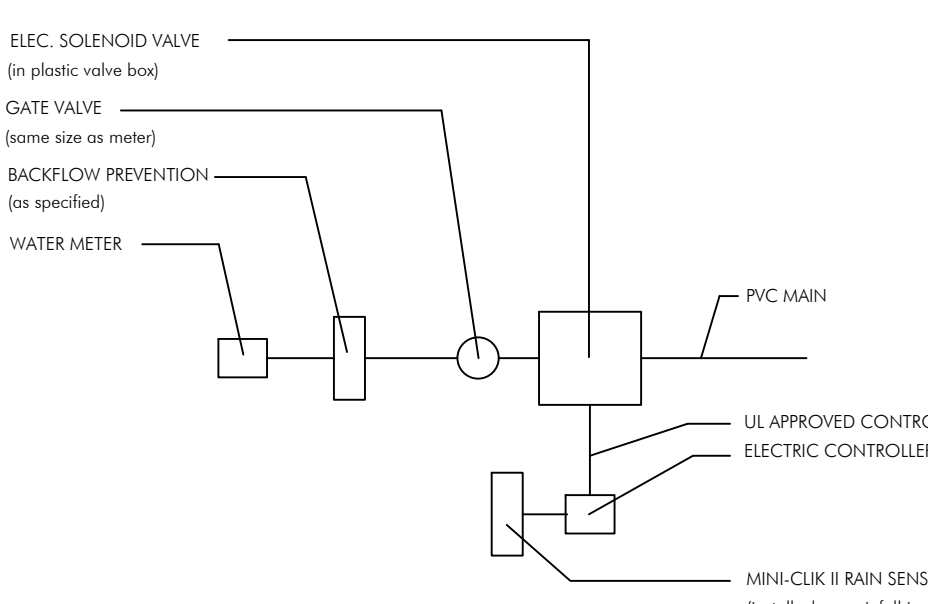

CONNECTION TO METER DETAIL

N.T.S.

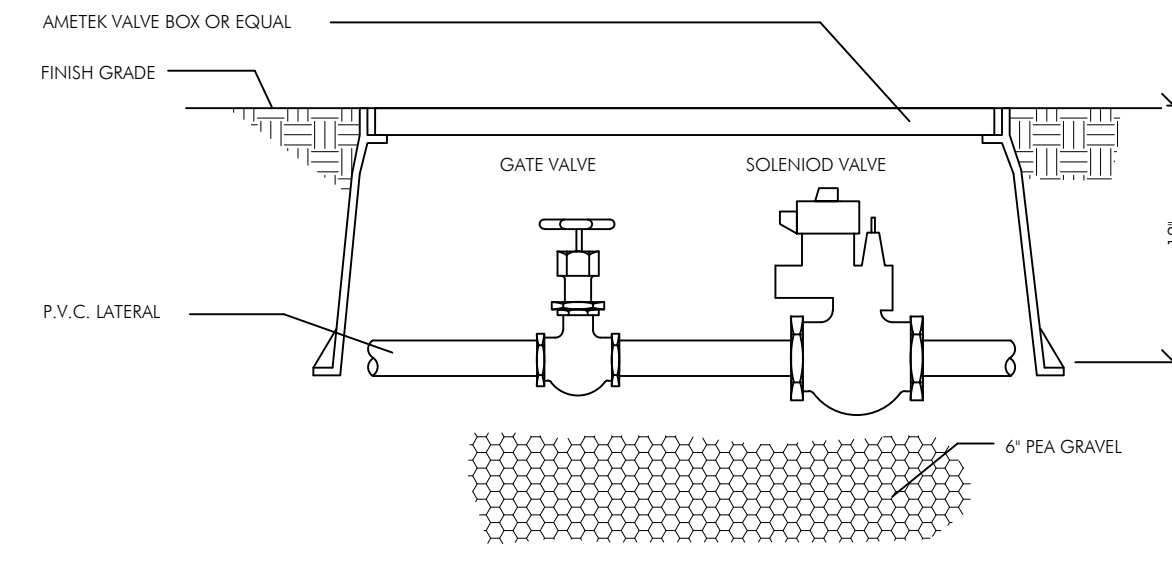

TYPICAL SOLENOID VALVE ASSEMBLY

N.T.S.

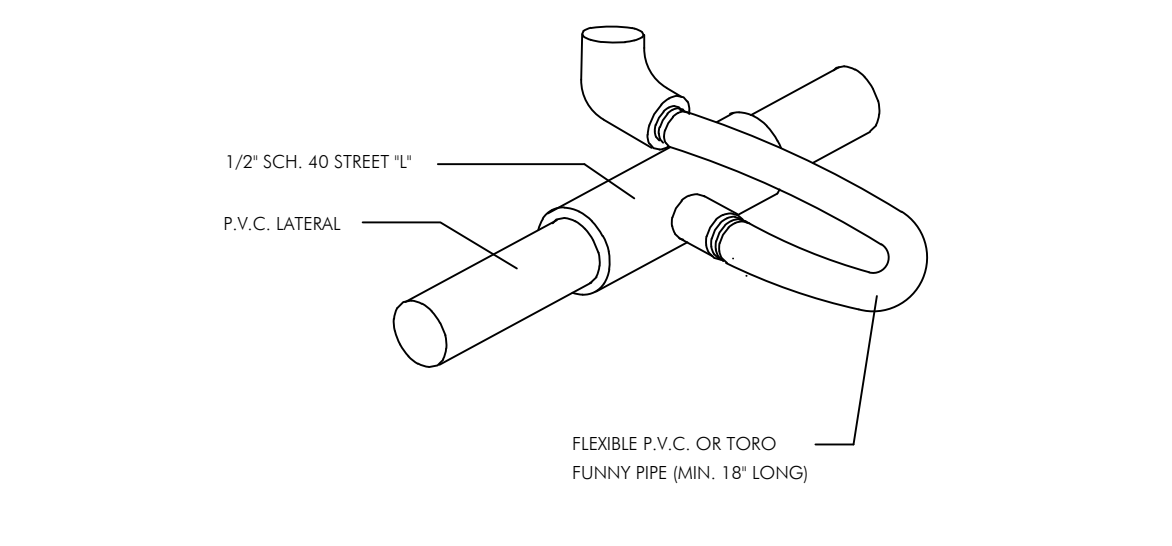

FLEXIBLE SWING JOINT DETAIL

N.T.S.

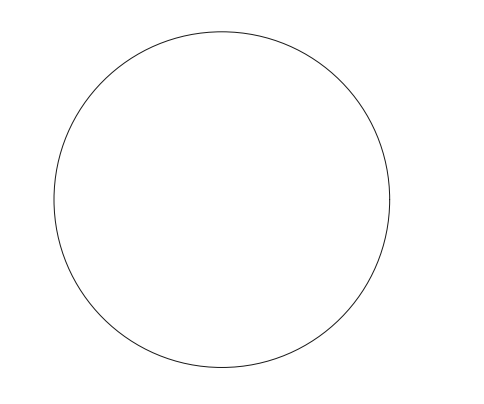

Vertical text on the left margin containing project details and disclaimer.