



**citizenM Hotels**  
1634 ALTON ROAD, MIAMI BEACH, FL 33139

**Gensler**  
Lic. No. AA002837

**MAIN OFFICE**  
45 Fremont Street  
Suite 1500  
San Francisco, CA 94105  
USA  
T 415.433.3700

**MIAMI OFFICE**  
545 NW 26th St  
Suite 250  
Miami, FL 33127  
USA  
T 305.529.7070

**CONCEPT ARCHITECT**  
concrete  
oudezijds achterburgwal 78a  
1012 dr amsterdam NL

**STRUCTURAL**  
YOUSSEF HACHEM CONSULTING ENGINEERING, INC  
99 NW 27 AVE  
Miami, FL 33125  
T 305.689.8473

**MEP/FP/T**  
BR-A CONSULTING ENGINEERS  
3500 Douglas Road, Suite 1100  
Coral Gables, FL 33134  
T 305.529.1515

**CIVIL**  
MILLER LEGG  
5747 N. Andrews Way  
Fort Lauderdale, FL 33309  
T 954.436.7000

**LANDSCAPE ARCHITECTS**  
URBAN ROBOT LLC  
420 Lincoln Rd #600  
Miami Beach, FL 33139  
T 786.246.4857

**ACOUSTICS**  
ACENTECH  
33 Moulton Street  
Cambridge MA 02138  
T 617.499.8000

**POOL CONSULTANT**  
AQUADYNAMICS  
3500 SW 75th Ave, Suite 103  
Miami, FL 33155  
T 305.667.8975

**FOOD**  
RICCA DESIGN STUDIOS  
5325 S. Valerita Way  
Greenwood Village, CO 80111  
T 303.928.1362

**VERTICAL TRANSPORTATION**  
LERCH BATES  
9780 S. Meridian Boulevard, Suite 450  
Englewood, CO 80112  
T 303.795.7956

**LIFE SAFETY**  
SLS CONSULTING  
280 Palermo Ave  
Coral Gables, FL 33134  
T 305.461.9852

Seal / Signature

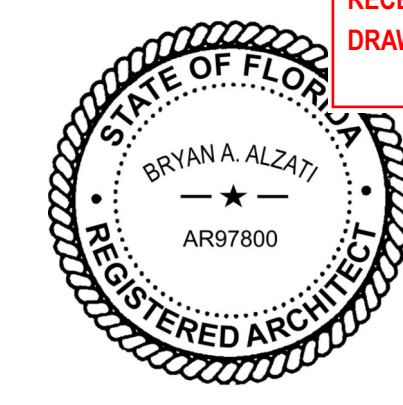

Bryan Alzati AIA, REG. FL. No. AR97800

Date	Description
04/19/2019	Stage 2.1 - SCHEMATIC DESIGN
08/16/2019	Stage 3.0 - DESIGN DEVELOPMENT
10/25/2019	STAGE 4.0 - CONSTRUCTION DOCUMENTS
11/04/2019	ISSUE FOR PERMIT
08/17/2020	STAGE 4.0 100% VE Issuance
08/13/2021	STAGE 4.0 BID ISSUANCE
11/30/2022	REVISION 10 / IFC

**Project Name**  
citizenM Miami South Beach

**Project Number**  
79.0337.000

**Description**  
SURVEY

**Scale**

**G00.002**

© 2019 Gensler

### ALTA/NSPS LAND TITLE SURVEY

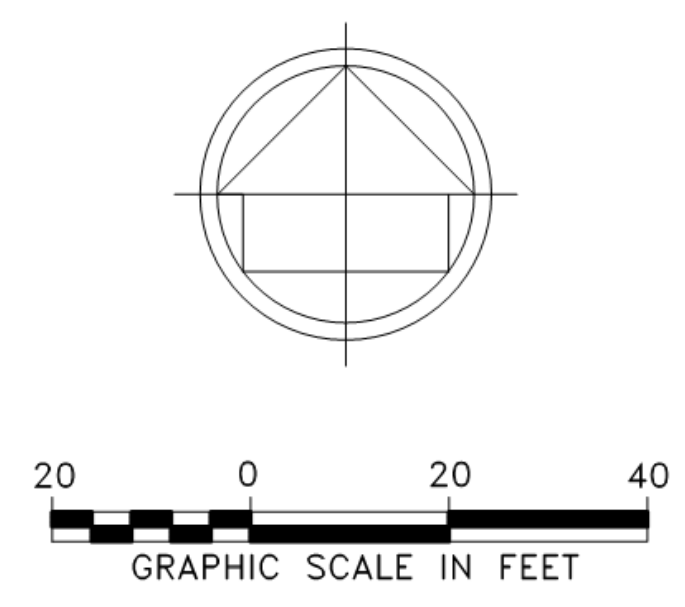
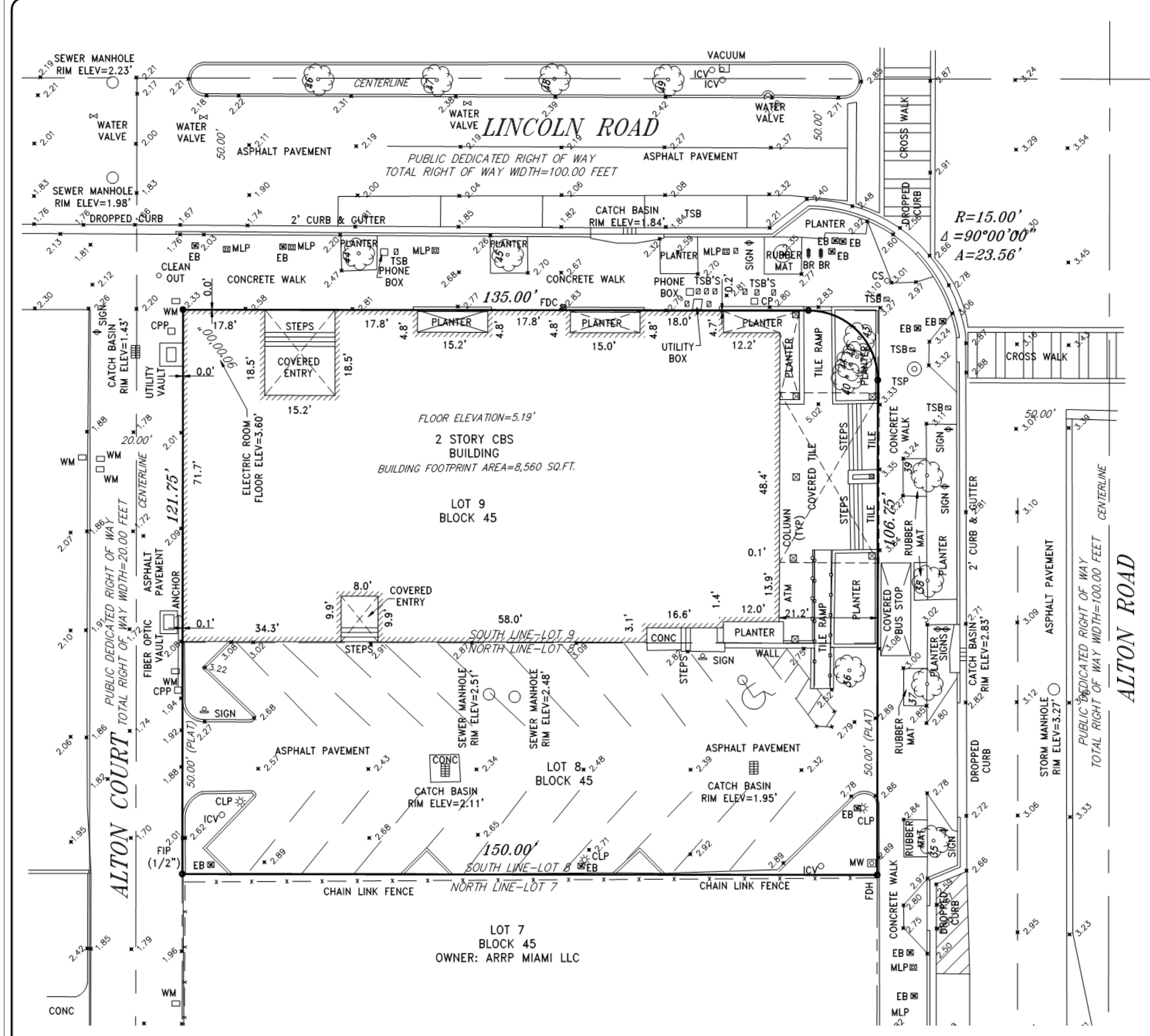

LOCATION MAP (NTS)

TREE NO. ON SURVEY	SPECIES		TRUNK DIA. AT BREAST HEIGHT INCHES	# OF TRUNKS	TREE HEIGHT FEET	CANOPY SPREAD FEET	CANOPY (SF)
	COMMON NAME	SCIENTIFIC NAME					
35	OAK		5	1	18	7	
36	BLACK OLIVE		14	1	27	30	
37	PALM		8	2	20	20	
38	PALM		8	2	17	18	
39	PALM		8	2	17	18	
40	PALM		12	1	20	15	
41	PALM		25	1	34	18	
42	PALM		10	1	22	12	
43	PALM		6	1	18	12	
44	PALM		17	1			
45	PALM		21	1			
46	PALM		22	1			
47	PALM		25	1			
48	PALM		20	1			
49	PALM		18	1			

**LAND DESCRIPTION:**  
LOTS 8 AND 9, BLOCK 45, OF COMMERCIAL SUBDIVISION, ALTON BEACH REALTY COMPANY, ACCORDING TO THE PLAT THEREOF, AS RECORDED IN PLAT BOOK 6, PAGE 5, OF THE PUBLIC RECORDS OF MIAMI-DADE COUNTY, FLORIDA.

- NOTES :**
- NOT VALID WITHOUT THE SIGNATURE AND THE ORIGINAL RAISED SEAL OF A FLORIDA LICENSED SURVEYOR AND MAPPER.
  - THE CERTIFICATION SHOWN HEREON TO THE EXTENT RELATING TO THE EXISTENCE OF EASEMENTS AND/OR RIGHTS-OF-WAY OF RECORD IS BASED UPON COMMITMENT FOR TITLE INSURANCE ISSUED BY INSURANCE COMPANY. EFFECTIVE DATE: /2018. ORDER NO.:
  - THIS SURVEY WAS DONE SOLELY FOR BOUNDARY PURPOSES AND DOES NOT DEPICT THE JURISDICTION OF ANY MUNICIPAL, STATE, FEDERAL OR OTHER ENTITIES.
  - THE LAND DESCRIPTION SHOWN HEREON WAS PROVIDED BY THE CLIENT.
  - UNDERGROUND IMPROVEMENTS NOT SHOWN.
  - ELEVATIONS SHOWN HEREON ARE BASED ON THE NATIONAL GEODETIC VERTICAL DATUM OF 1929.
  - BENCHMARK REFERENCE : MIAMI/DADE COUNTY BENCHMARK ELEVATION=
  - ALL UTILITIES SERVING THE PROPERTY ENTER THROUGH ADJOINING PUBLIC STREETS AND/OR EASEMENTS OF RECORD.
  - THE PROPERTY IS LOCATED WITHIN AN AREA HAVING A ZONE DESIGNATION "AE/8" BY THE FEDERAL EMERGENCY MANAGEMENT AGENCY (FEMA), ON FLOOD INSURANCE RATE MAP NO. 0317 L, WITH A DATE OF IDENTIFICATION OF 09/11/09, FOR COMMUNITY NO. 120651, IN MIAMI/DADE COUNTY, STATE OF FLORIDA WHICH IS THE CURRENT FLOOD INSURANCE RATE MAP FOR THE COMMUNITY IN WHICH THE PROPERTY IS SITUATED.

- THERE ARE NO ENCROACHMENTS ONTO ADJOINING PREMISES, STREETS OR ALLEYS BY ANY BUILDINGS, STRUCTURES OR OTHER IMPROVEMENTS LOCATED ON THE PROPERTY, AND NO ENCROACHMENTS ONTO THE PROPERTY BY BUILDINGS, STRUCTURES OR OTHER IMPROVEMENTS SITUATED ON ADJOINING PREMISES.
- THE PROPERTY HAS DIRECT ACCESS TO 16TH STREET AND ALTON ROAD, A DEDICATED PUBLIC STREET AS SHOWN ON PLAT BOOK 6, PAGE 5, SAME BEING PAVED AND DEDICATED PUBLIC ROADWAYS MAINTAINED BY THE CITY OF MIAMI/BEACH, MIAMI/DADE COUNTY, FLORIDA.
- THERE ARE 21 STRIPED PARKING SPACES INCLUDING 1 HANDICAP SPACE ON THE PROPERTY.
- THERE IS NO OBSERVED EVIDENCE OF CURRENT EARTH MOVING WORK, BUILDING CONSTRUCTION OR BUILDING ADDITIONS AT THE PROPERTY.
- THERE IS NO PROPOSED CHANGES IN STREET RIGHT OF WAY LINES AFFECTING THE PROPERTY, ACCORDING TO BROWARD COUNTY, FLORIDA.
- THERE IS NO OBSERVED EVIDENCE OF RECENT STREET OR SIDEWALK CONSTRUCTION OR REPAIRS AFFECTING THE PROPERTY.
- THERE IS NO OBSERVED EVIDENCE OF USE OF THE PROPERTY AS A SOLID WASTE DUMP, SUMP OR SANITARY LANDFILL.

CD-2 COMMERCIAL, MEDIUM INTENSITY DISTRICT				
MAX BUILDING HEIGHT=50 FEET				
	FRONT	SIDE INTERIOR	SIDE, FACING STREET	REAR
AT-GRADE PARKING LOT ON THE SAME LOT	5 FEET	5 FEET	5 FEET	5 FEET IF ABUTTING AN ALLEY—0 FEET
SUBTERRANEAN, PEDESTAL AND TOWER (NON-OCEANFRONT)	0 FEET RESIDENTIAL USES SHALL FOLLOW THE RM-1, 2, 3 SETBACKS	10 FEET WHEN ABUTTING A RESIDENTIAL DISTRICT, OTHERWISE NONE RESIDENTIAL USES SHALL FOLLOW THE RM-1, 2, 3 SETBACKS	10 FEET WHEN ABUTTING A RESIDENTIAL DISTRICT, UNLESS SEPARATED BY A STREET OR WATERWAY OTHERWISE NONE RESIDENTIAL USES SHALL FOLLOW THE RM-1, 2, 3 SETBACKS	5 FEET WHEN ABUTTING A RESIDENTIAL DISTRICT UNLESS SEPARATED BY A STREET OR WATERWAY IN WHICH CASE IT SHALL BE 0 FEET. RESIDENTIAL USES SHALL FOLLOW THE RM-1, 2, 3 SETBACKS
SUBTERRANEAN, PEDESTAL AND TOWER (OCEANFRONT)	PEDESTAL--15 FEET TOWER--20 FEET + 1 FOOT FOR EVERY 1 FOOT HEIGHT ABOVE 50 FEET, TO A MAXIMUM OF 50 FEET, THEN SHALL REMAIN CONSTANT. RESIDENTIAL USES SHALL FOLLOW THE RM-1, 2, 3 SETBACKS	COMMERCIAL USES--10 FEET RESIDENTIAL USES SHALL FOLLOW THE RM-1, 2, 3 SETBACKS	COMMERCIAL USES--10 FEET RESIDENTIAL USES SHALL FOLLOW THE RM-1, 2, 3 SETBACKS	25% OF LOT DEPTH, 75 FEET MINIMUM FROM THE BULKHEAD LINE WHICHEVER IS GREATER RESIDENTIAL USES SHALL FOLLOW THE RM-1, 2, 3 SETBACKS

- LEGEND:**
- |          |                           |      |  |
|----------|---------------------------|------|--|
| CKD      | CHECKED BY                | TSP  | TRAFFIC SIGNAL POLE                        |
| CONC     | CONCRETE                  | PM   | PARKING METER                              |
| DWN      | DRAWN BY                  | MLP  | METAL LIGHT POLE                           |
| FB/PG    | FIELD BOOK AND PAGE       | EB   | ELECTRIC BOX                               |
| SIR      | SET IRON ROD & CAP #6448  | 5.40 | ELEVATIONS                                 |
| SNC      | SET NAIL AND CAP #6448    | ALTA | AMERICAN LAND TITLE ASSOCIATION            |
| FIR      | FOUND IRON ROD            | NSPS | NATIONAL SOCIETY OF PROFESSIONAL SURVEYORS |
| FIP      | FOUND IRON PIPE           | TC   | TRASH CAN                                  |
| FNC      | FOUND NAIL AND CAP        | FDC  | FIRE DEPARTMENT CONNECTION                 |
| FND      | FOUND NAIL & DISC         | MW   | MONITORING WELL                            |
| P.B.     | PLAT BOOK                 | CP   | CONCRETE POLE                              |
| M/D.C.R. | MIAMI/DADE COUNTY RECORDS | FPL  | FLORIDA POWER & LIGHT                      |
| CBS      | CONCRETE BLOCK STRUCTURE  | CPP  | CONCRETE POWER POLE                        |
| A/C      | AIR CONDITIONER           | CLP  | CONCRETE LIGHT POLE                        |
| WM       | WATER METER               | BR   | BIKE RACK                                  |
| WV       | WATER VALVE               | ICV  | IRRIGATION CONTROL VALVE                   |
| CO       | CLEAN OUT                 | R    | RADIUS                                     |
| TSB      | TRAFFIC SIGNAL BOX        | A    | ARC DISTANCE                               |
| SQ.FT    | SQUARE FEET               | △    | CENTRAL ANGLE                              |
|          |                           | ♿    | HANDICAP PARKING SPACE                     |

**SURVEYOR'S CERTIFICATION**

THIS IS TO CERTIFY THAT THIS MAP OR PLAT AND THE SURVEY ON WHICH IT IS BASED WERE MADE IN ACCORDANCE WITH THE "2016 MINIMUM STANDARD DETAIL REQUIREMENTS FOR ALTA/NSPS LAND TITLE SURVEYS," JOINTLY ESTABLISHED AND ADOPTED BY ALTA AND NSPS, AND INCLUDES ITEMS 1, 2, 3, 4, 6(A), 6(B) (NONE SUPPLIED), 7(A), 7(B), 7(C), 8, 9, 10(A), 13, 16, 17 AND 20 OF TABLE A THEREOF. THE FIELD WORK WAS COMPLETED ON OCTOBER 18, 2018. SAID PROPERTY IS LOCATED WITHIN AN AREA HAVING A ZONE DESIGNATION OF "AE/8" BY THE BY THE SECRETARY OF HOUSING AND URBAN DEVELOPMENT, ON FLOOD INSURANCE RATE MAP NO. 0317 L, WITH A DATE OF IDENTIFICATION OF 09/11/09, FOR COMMUNITY NUMBER 120651, IN MIAMI-DADE COUNTY, STATE OF FLORIDA, WHICH IS THE CURRENT FLOOD INSURANCE RATE MAP FOR THE COMMUNITY IN WHICH SAID PROPERTY IS SITUATED.

DATE OF PLAT OR MAP: DECEMBER 17, 2018.

FOR THE FIRM BY: \_\_\_\_\_  
RICHARD E. COUSINS  
PROFESSIONAL SURVEYOR AND MAPPER  
FLORIDA REGISTRATION No. 4188.

1628 ALTON ROAD  
MIAMI BEACH, FL 33139  
1634 ALTON ROAD  
MIAMI BEACH, FL 33139

**COUSINS SURVEYORS & ASSOCIATES, INC.**  
3921 SW 47TH AVENUE, SUITE 1011  
DAVIE, FLORIDA 33314  
CERTIFICATE OF AUTHORIZATION : LB # 6448  
PHONE (954) 689-7766 FAX (954) 689-7799

**CLIENT :**  
CRESCENT HEIGHTS  
MIAMI/BEACH FLORIDA

ALTA/NSPS LAND TITLE SURVEY

REVISIONS			
ALTA/NSPS LAND TITLE SURVEY	DATE	FB/PG	DWN
UPDATE SURVEY	10/18/18	SKETCH	AM
	02/28/19	SKETCH	JD

PROJECT NUMBER : 8101-16  
SCALE : 1" = 20'

SHEET 1 OF 1 SHEET

4/26/2023 12:24:14 PM B:\360-1075-0337-000 - citizenM - Miami South Beach\79.0337.000 - Citizen M Miami Beach\_2018.rvt